

ARNO[®]

WERKZEUGE

We have a passion for precision.

FRÄSEN UND GEWINDEFÄSEN

2014

Werkzeuge und Wendeschneidplatten zum Fräsen und Gewindefräsen

*Milling cutters and indexable inserts
for milling and thread milling*

Utensili ed inserti di fresatura e
di filettatura di fresatura

Übersicht

Program overview
Famiglie prodotti

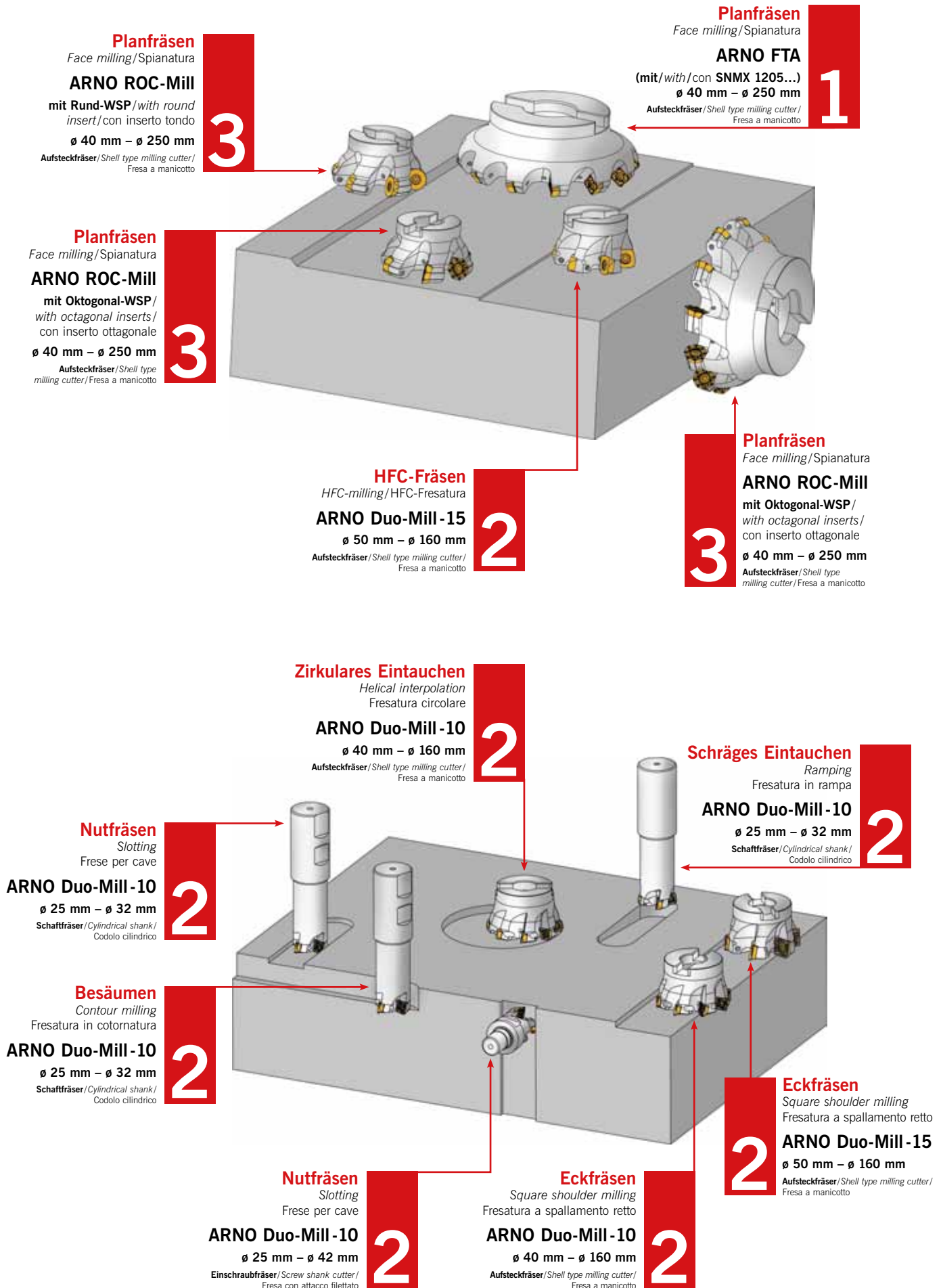

Seite / Page / Pagina

Über uns	<i>About us</i>	Chi siamo	4 / 12 / 20	0
Service weltweit	<i>Service worldwide</i>	Nel mondo	8 / 16 / 24	
ARNO-Frässysteme	<i>Milling Systems</i>	Sistemi di fresatura	10 / 18 / 26	

Frässystem FTA	<i>FTA milling system</i>	Sistema di fresatura FTA	30 – 33	1
<ul style="list-style-type: none"> • Systemvorstellung • Trägerwerkzeuge • Wendeschneidplatten 	<ul style="list-style-type: none"> • <i>System introduction</i> • <i>Holders</i> • <i>Indexable inserts</i> 	<ul style="list-style-type: none"> • Caratteristiche del sistema • Corpi fresa • Inserti 	34	
			35 – 37	

Frässystem Duo-Mill	<i>Duo-Mill milling system</i>	Sistema di fresatura Duo-Mill	46 – 49	2
<ul style="list-style-type: none"> • Systemvorstellung • Trägerwerkzeuge • Wendeschneidplatten 	<ul style="list-style-type: none"> • <i>System introduction</i> • <i>Holders</i> • <i>Indexable inserts</i> 	<ul style="list-style-type: none"> • Caratteristiche del sistema • Corpi fresa • Inserti 	50 – 55	
			56 – 63	

Frässystem ROC-Mill	<i>ROC-Mill milling system</i>	Sistema di fresatura ROC-Mill	88 – 91	3
<ul style="list-style-type: none"> • Systemvorstellung • Trägerwerkzeuge • Wendeschneidplatten 	<ul style="list-style-type: none"> • <i>System introduction</i> • <i>Holders</i> • <i>Indexable inserts</i> 	<ul style="list-style-type: none"> • Caratteristiche del sistema • Corpi fresa • Inserti 	92 – 93	
			94 – 96	

ISO-Frässysteme	<i>ISO-milling systems</i>	Sistema di fresatura ISO	108 – 113	4
<ul style="list-style-type: none"> • Systemvorstellung • Trägerwerkzeuge 	<ul style="list-style-type: none"> • <i>System introduction</i> • <i>Holders</i> 	<ul style="list-style-type: none"> • Caratteristiche del sistema • Corpi fresa 	114 – 154	

Wendeschneidplatten	<i>Indexable inserts</i>	Inserti	180 – 181	5
<ul style="list-style-type: none"> • ISO-Bezeichnungssystem • ARNO-Spanformgeometrien • Wendeschneidplatten – Hartmetall – Hochpositiv – Cermet – Hochharte Schneidstoffe Geometrie-/Sortenbeschreibung – HSS-Schneidstoff 	<ul style="list-style-type: none"> • <i>ISO-Designation System</i> • <i>Chip Breakers</i> • <i>Indexable inserts</i> – <i>Carbide</i> – <i>High Positive</i> – <i>Cermet</i> – <i>CBN/PCD</i> <i>Geometry/Grades description</i> – <i>HSS</i> 	<ul style="list-style-type: none"> • Sistema di codifica ISO • Geometrie di taglio ARNO • Inserti – Metallo duro – Ultra Positivi – Cermet – Materiali extra duri Descrizione delle Geometrie/Qualità – HSS 	182 – 186	
			187 – 208	
			209 – 225	
			226 – 231	
			232 – 242	
			232 – 235	
			243 – 250	

Gewindefräsen	<i>Thread milling</i>	Filettatura	252 – 254	6
<ul style="list-style-type: none"> • Gewindearten • Gewindefräsen – Übersicht • Trägerwerkzeuge • Wendeschneidplatten 	<ul style="list-style-type: none"> • <i>Insert preselection</i> • <i>Thread Milling – Program overview</i> • <i>Holders</i> • <i>Indexable inserts</i> 	<ul style="list-style-type: none"> • <i>Insert preselection</i> • Fresatura per filettatura – Gamma prodotti • Corpi fresa • Inserti 	255	
			256 – 258	
			260 – 269	

Informationen	<i>Information</i>	Informazioni	272 – 276	i
<ul style="list-style-type: none"> • Vergleichstabellen • Verschleiß und Abhilfe • Anwendungshinweise • Empfohlene Schnittwerte 	<ul style="list-style-type: none"> • <i>Material – Cross Reference</i> • <i>Insert Wear and Solutions</i> • <i>Application Reference</i> • <i>Recommended Cutting Data</i> 	<ul style="list-style-type: none"> • Tabelle comparative • Problemi e suggerimenti • Esempi applicativi • Parametri di taglio 	277 – 279	
			280 – 288	
			290 – 316	

Alphanumerischer Index	<i>Alphanumerical index</i>	Indice alfanumerico	318	A
-------------------------------	-----------------------------	---------------------	-----	---

ARNO®

WERKZEUGE



1941

Emil Arnold (*24.7.1904), Meister bei Bosch, macht sich selbstständig und gründet Emil Arnold Lehrenbau in der Franziskanergasse 7 in Esslingen.

1962

Karl-Heinz Arnold gründet am 1. April Karl-Heinz Arnold Werkzeuge im väterlichen Betrieb. Zweck: Vertrieb von Hartmetallwerkzeugen.

1965

Umfirmierung von „Emil Arnold“ zur „Emil Arnold KG“ Unternehmenszweck: Herstellung von Spezialwerkzeugen und Vorrichtungen für Sondermaschinen sowie Serienfertigung von Spannwerkzeugen.

1966

Umzug der beiden Firmen in das Industriegebiet Ruit Zinsholz, Ostfildern bei Stuttgart.

1967

Beginn des Vertriebs von Wendschneidplatten aus Hartmetall für die Zerspaltung beim Drehen und beim Fräsen.

1979

Gemeinsam mit der eigenen Fertigung bei Emil Arnold setzt ARNO konsequent auf Marktlücken: Nach einer Entwicklungszeit von nur einem Jahr wird das Mini-Kopiersystem mit einer neuartigen, patentrechtlich geschützten Klemmung entwickelt.

1981

Weitere Entwicklung von eigenen Werkzeugen, die Marktlücken schließen z. B. NC-Stechdrehsystem.

1989

Einstieg in die Schleiftechnik.

Tradition in Präzision.

„Vom lokalen Familienunternehmen zum weltweiten Vertrieb.“

1941 gründet Emil Arnold den „Lehrenbau“ in Esslingen am Neckar. Anfänglich fertigt er hauptsächlich Messvorrichtungen und Prüflehren. Schon damals hat er sich durch die hervorragende Qualität seiner Produkte einen Namen gemacht. Besonders, weil er auf die Kunden eingeht und deren Wünsche präzise erfüllt.

Zusammen mit seinem Sohn Karl-Heinz Arnold steckt er viel Herzblut in die Firma und ist immer offen für neue Entwicklungen. Er hat die Vision, mit seinen Werkzeugen in den Fertigungen aller Länder und Branchen vertreten zu sein. 1962 gründet sein Sohn die Firma Karl-Heinz Arnold GmbH, die sich fortan unter dem Namen ARNO-Werkzeuge vor allem dem Vertrieb von Hartmetallwerkzeugen widmet. Zusammen beschäftigen sich die beiden Firmen konsequent mit Marktlücken, haben immer die Wünsche der Kunden im Auge.

1987 tritt Klaus-Michael Arnold in die Firma ein und wird 1992 Geschäftsführer. Zusammen mit Josef Storf, 2002 zum Geschäftsführer ernannt, werden im Sinne des Firmengründers das Produktsortiment ständig ausgebaut und neue Vertriebswege gesucht. 2004 ist es dann soweit: Im Ausland, bereits über Vertriebspartner etabliert, wird die erste Niederlassung in England gegründet. Bald darauf folgen Italien, Russland und die USA. Durch die stetige Weiterentwicklung des Programms und dank sehr gutem Serviceangebot ist ARNO-Werkzeuge bis heute weltweit anerkannt für seine hochpräzisen Zerspanungswerkzeuge.

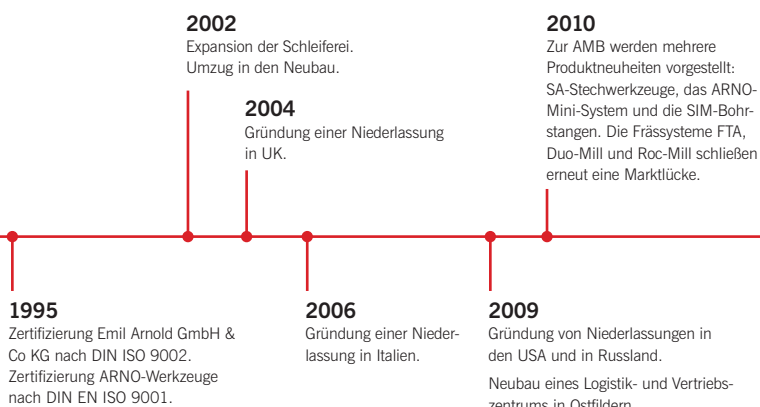
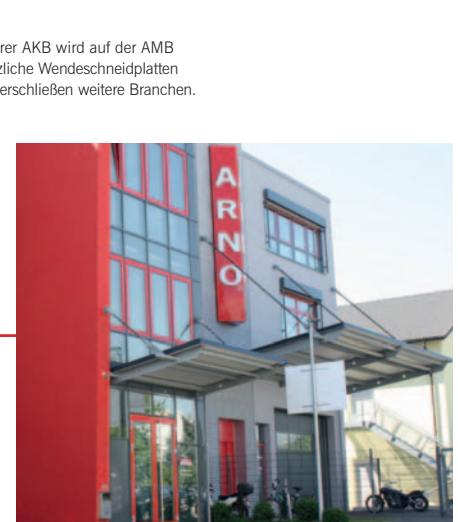

ARNO®

WERKZEUGE

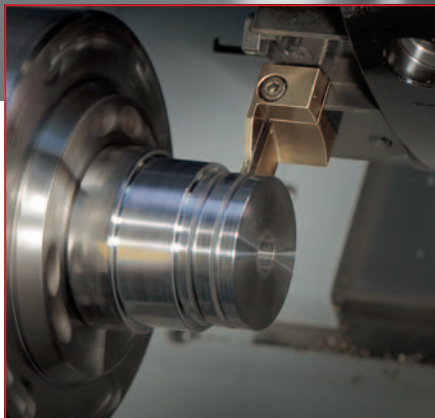

Stechen

Ob Radial- oder Axial-Stechdrehen, Abstechen, Langdrehen oder Innenstechdrehen – Sie finden bei ARNO-Werkzeuge für jede Anwendung das optimale Stechwerkzeug.

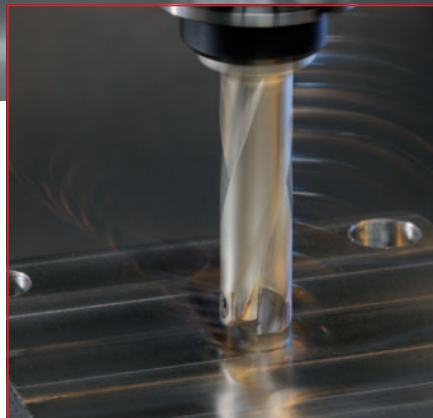

Bohren

Von 1 mm bis 114 mm Durchmesser sind Bohrer mit auswechselbaren Schneidplatten und VHM-Spiralbohrer zur Innen- und Außenbearbeitung in unserem Produktportfolio vertreten.



Drehen

ARNO-Werkzeuge bietet zuverlässige Werkzeuge, mit den unterschiedlichsten Wendeschneidplatten, für höchste Ansprüche in der Innen- und Außenbearbeitung sowie zum Gewindedrehen.

Stärke durch Erfahrung, Kompetenz und Entwicklung.

„Für die Zukunft brauchen Sie einen Partner mit Zukunft.“

Durch intensive Zusammenarbeit innerhalb und außerhalb der Firma sind wir in der Lage, individuelle Kundenwünsche mit unserem Know-how zu erfüllen. Dabei entwickeln wir ständig neue Sonderwerkzeuge, um diese dann später auch in unser Standardprogramm aufzunehmen.

Neue Werkstoffe, ebenso wie die Anforderungen nach ständig steigenden Bearbeitungsgeschwindigkeiten, fordern uns, zu forschen und neue Produkte auf den Markt zu bringen. Es gilt, modulare Werkzeugsysteme anzufertigen, die individuell für unterschiedlichste Einsatzbereiche angepasst werden. Unsere leistungsfähige und trotzdem wirtschaftliche Produktpalette beinhaltet vom Bohrsystem über Stechwerkzeuge, Fräsköpfe und einer Vielfalt an Wendeschneidplatten (nicht nur zum Drehen) auch Werkzeugaufnahmen und Werkzeugautomaten.

Neben qualitativ einwandfreien Produkten sind fachliche Beratung und Betreuung für uns selbstverständlich. **Unser kompetentes Team erfüllt Ihre Wünsche und hilft Ihnen mit Service nach Maß auch nach Ihrer Kaufentscheidung.**



Fräsen

Planfräser, Eckfräser, Fasfräser, Fräser mit runden oder eckigen Wendeschneidplatten, Schrufffräser. Auch für Ihre Anwendung finden Sie einen passenden Fräser.



Werkzeugautomaten

Sichere Werkzeugaufbewahrung, -verfolgung und -entnahme garantiert Ihnen der flexibel konfigurierbare StoreManager.



Werkstückspannung

NC-Schraubstöcke in einfacher oder doppelter Ausführung für perfekt gespannte Werkstücke in der modernen Fertigung.

Service nach Maß.

Individuelle Sonderlösungen

Mit unserem breiten Produktsortiment sind wir bestens für nahezu jede Herausforderung gerüstet. **Sie haben dennoch eine ganz besondere Aufgabe, die besonderes Werkzeug verlangt?** Dann wenden Sie sich an uns, denn ARNO produziert auch kundenorientierte Sonderlösungen – optimal auf Ihre Bedürfnisse zugeschnitten. Das garantiert perfekte Ergebnisse ohne Einschränkungen.

Lieferung über Nacht

Für Sie muss es richtig schnell gehen? Kein Problem, denn wenn Sie die **Bestellung Ihrer Produkte bis 18 Uhr (freitags bis 16 Uhr) abschließen, steht am nächsten Tag ein Fahrer vor Ihrer Tür.** Dieses Angebot gilt nur für unsere Lagerware, denn um die Qualität unserer individuellen Sonderlösungen zu garantieren, nehmen wir uns für diese auch etwas mehr Zeit.

Alles unter einem Dach

Die **hohe Qualität unserer Produkte** basiert nicht zuletzt darauf, dass **die Konstruktion, die Produktion und der Vertrieb bei ARNO auf einem Gelände stattfinden.** Das ermöglicht uns ausgiebige Testverfahren, schnellere Reaktionszeiten, bessere Kontrolle und – einen günstigeren Preis.

Großes Außendienst-Team

Wir lassen Sie mit unseren Produkten nicht allein. Das ARNO-Außendienst-Team besucht Sie regelmäßig und unterstützt Sie mit umfassendem Produktwissen und Support.

Unsere Anwendungstechniker

Sie haben ein Problem in Ihrer Zerspanung festgestellt oder haben eine Frage, die Sie nur vor Ort klären können? Unsere Anwendungstechniker besuchen Sie in Ihrem Werk und unterstützen Sie bei Technikfragen.

Unsere Bestell-Hotline

Sie haben die Möglichkeit in nahezu allen Ländern der Welt einen unserer ARNO-Mitarbeiter zu erreichen. Profitieren Sie von unserer zuverlässigen und kompetenten Fachberatung am Telefon. Für komplexere Fragen stehen Ihnen persönliche Ansprechpartner zur Verfügung.

Weltweit im Einsatz – Ihr Service direkt vor Ort.

ARNO-Werkzeuge finden Sie überall auf der Welt. Uns ist es wichtig, nicht nur zentral von einem Punkt aus unsere Kunden zu betreuen. Vielmehr möchten wir Ihnen als Kunden einen lokalen Service bieten. Mit Vertriebspartnern und Niederlassungen in vielen Ländern der Welt sind wir für Sie einfach zu erreichen.

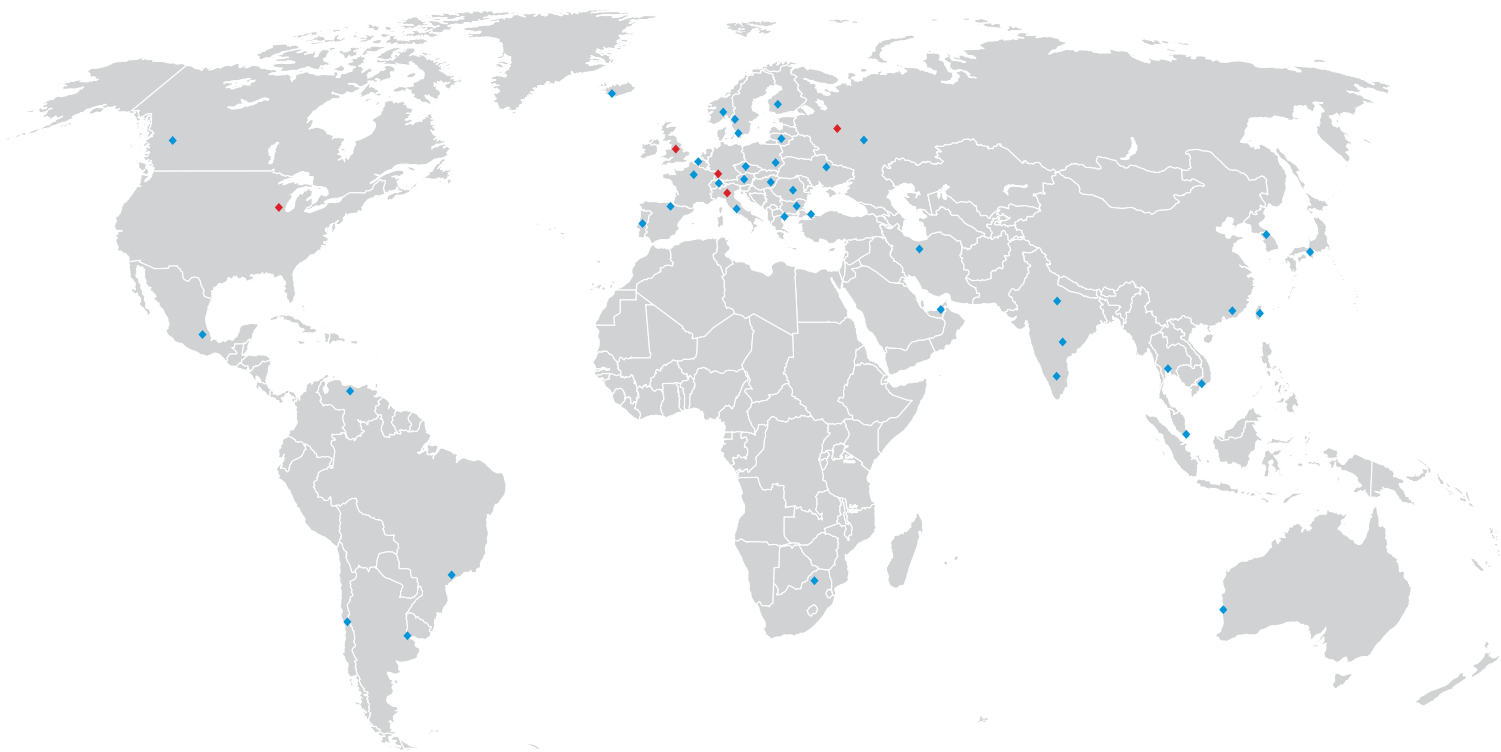

◆ Niederlassungen

◆ Vertriebspartner

Karl-Heinz Arnold GmbH
Karlsbader Str. 4
73760 Ostfildern

Tel.: +49 (0) 711/34 802-0
Fax: +49 (0) 711/34 802-130
bestellung@arno.de
anfrage@arno.de
www.arno.de

ARNO (UK) Limited | Unit 3, Sugnall Business Centre | Sugnall, Eccleshall | Staffordshire | ST21 6NF
☎ +44 01785 850 072 | 📠 +44 01785 850 076 | sales@arno.de | www.arno-tools.co.uk

ARNO Italia S.r.l | Via J. F. Kennedy 19 | 20871 Vimercate (MB)
☎ +39 039 68 52 101 | 📠 +39 039 60 83 724 | info@arno-italia.it | www.arno-italia.it

ARNO-Werkzeuge USA LLC | 1101 W. Diggins St. | US-60033 Harvard, Illinois
☎ +1 815 943 4426 | 📠 +1 815 943 7156 | info@arnousa.com | www.arnousa.com

ARNO RU Ltd. | Krassnaja Ul. 38 | RU-600015 Vladimir
☎/📠 +7 4922 541125 | 📠 +7 4922 541135 | info@arnoru.ru | www.arnoru.ru

ARNO[®]

WERKZEUGE



ab Seite 29

ARNO[®]-Frässystem FTA

Der universelle Planfräser zur Kostenreduzierung!



ab Seite 45

ARNO[®]-Frässystem Duo-Mill

Eckfräsen und HFC-Fräsen mit nur einem Werkzeug!



ab Seite 87

ARNO[®]-Frässystem ROC-Mill

Der positiv weichschneidende Planfräser, der eine Rundplatte und eine oktagonale Wendschneidplatte in einem Plattensitz vereint.

Die Kunst des Fräsens.

Fräsen ist ein wesentlicher Bestandteil der spanenden Fertigungstechnik in der Metallverarbeitung, die der Formgebung dient. Um bestmögliche Ergebnisse zu erzielen ist hierbei höchste Genauigkeit gefragt.

Hightech mit Präzision.

Hohe Standzeiten, neue Materialien, steigende Kundenerwartungen – gerade bei Schneidwerkzeugen in der Metallverarbeitung wachsen die Anforderungen konstant.

Eine Herausforderung, die wir gerne annehmen. Denn wir möchten den Marktbedingungen mehr als nur gerecht werden: Mit stetigen Neu- und Weiterentwicklungen, hochmodernen Verarbeitungstechniken und optimierten Schneidengeometrien setzen wir neue Maßstäbe.



ab Seite 107

Fräsen ISO

Planfräser, Schruppfräser, Eckfräser, Fasfräser, Fräser mit runden oder eckigen Wendeschneidplatten. Auch für Ihre Anwendung finden Sie hier einen passenden Fräser.

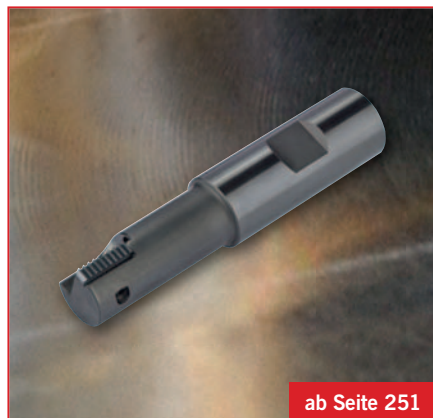

ab Seite 251

Gewindefräser

Trägerwerkzeuge und Schneidplatten zum Fräsen unterschiedlicher Gewindearten. Im Bereich metrische ISO-Gewinde können Sie unter Schneideinsätzen von M1,6 bis M300 auswählen.



siehe Katalog Tiefstpreise

VHM-Fräser und -Gewindefräser

Im Katalog Tiefstpreise finden Sie unser gesamtes Produktportfolio an Vollhartmetallfräsern für nahezu alle gängigen Werkstoffe und Anwendungen.

ARNO®

WERKZEUGE



1941

Emil Arnold (*24.7.1904), decides to become self-employed and establishes "Emil Arnold Lehrenbau" in Franziskanergasse 7 in Esslingen.

1962

On April 1st, Karl-Heinz Arnold establishes "Karl-Heinz Arnold Werkzeuge" in his father's company. Purpose: Sales of carbide cutting tools.

1965

Company re-structuring from "Emil Arnold" to "Emil Arnold KG" and more focus on manufacturing of special tools and jigs for special purpose machines as well as mass production of toolholders.

1966

Both companies moving to the industrial area of "Ruit Zinsholz", Ostfildern near Stuttgart.

1967

Start of sales for indexable carbide inserts for turning and milling.

1979

Together, in a combined production facility with "Emil Arnold", ARNO starts focusing on market opportunities. After only one year of research and development a mini copy turning system with a patented insert clamping is introduced.

1981

More developments of own tools, for example the NC-grooving and turning system.

1989

Entering into grinding technology.

Tradition in precision.

“Local family business gains global position as a market leader.”

In 1941 Emil Arnold establishes “Lehrenbau” in Esslingen am Neckar. Initially manufacturing mainly measurement jigs and gauges. Because he always gave his customers exactly what they specified he established himself through the high quality of his products.

Together with his son Karl-Heinz Arnold they put their heart and soul into the company and were always open to new developments. He had a vision to be represented with his cutting tools in all industries all over the world. In 1962 his son forms the company Karl-Heinz Arnold GmbH which under the name ARNO-Werkzeuge began focussing on sales of carbide tools. Both companies were constantly looking for market opportunities with the customers in mind.

In 1987 Klaus-Michael Arnold joined the company and became Managing Director in 1992. In 2002 Josef Storf became joint Managing Director. In the spirit of the company founder, the product portfolio is expanding and the search for new sales channels are constantly being explored. In 2004 ARNO (UK) Ltd becomes the first overseas sister company, followed by sister companies in Italy, Russia and the USA. Due to the constant developments of the product range and the high level of service provided, today ARNO-Werkzeuge is globally renowned for its high quality cutting tools.

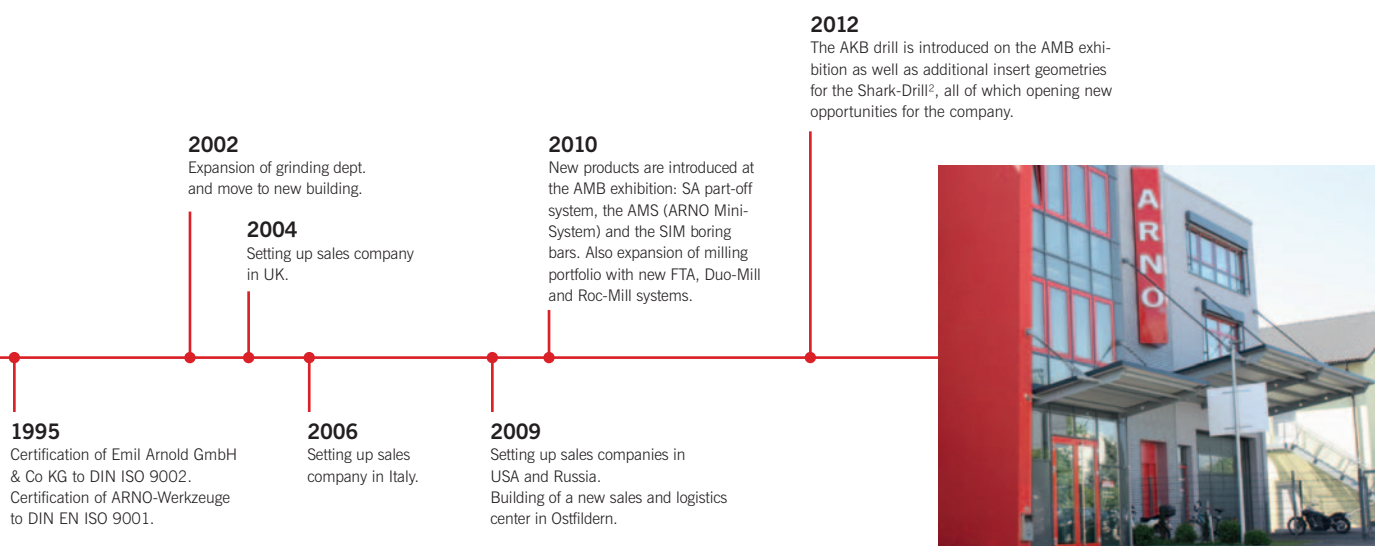

ARNO[®]

WERKZEUGE

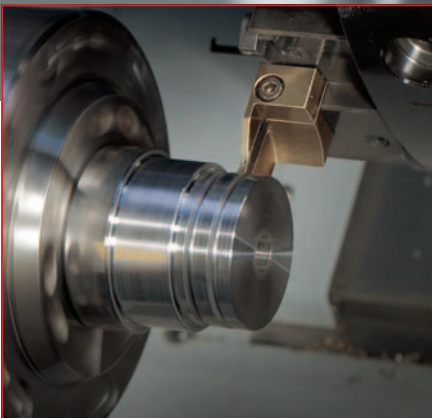
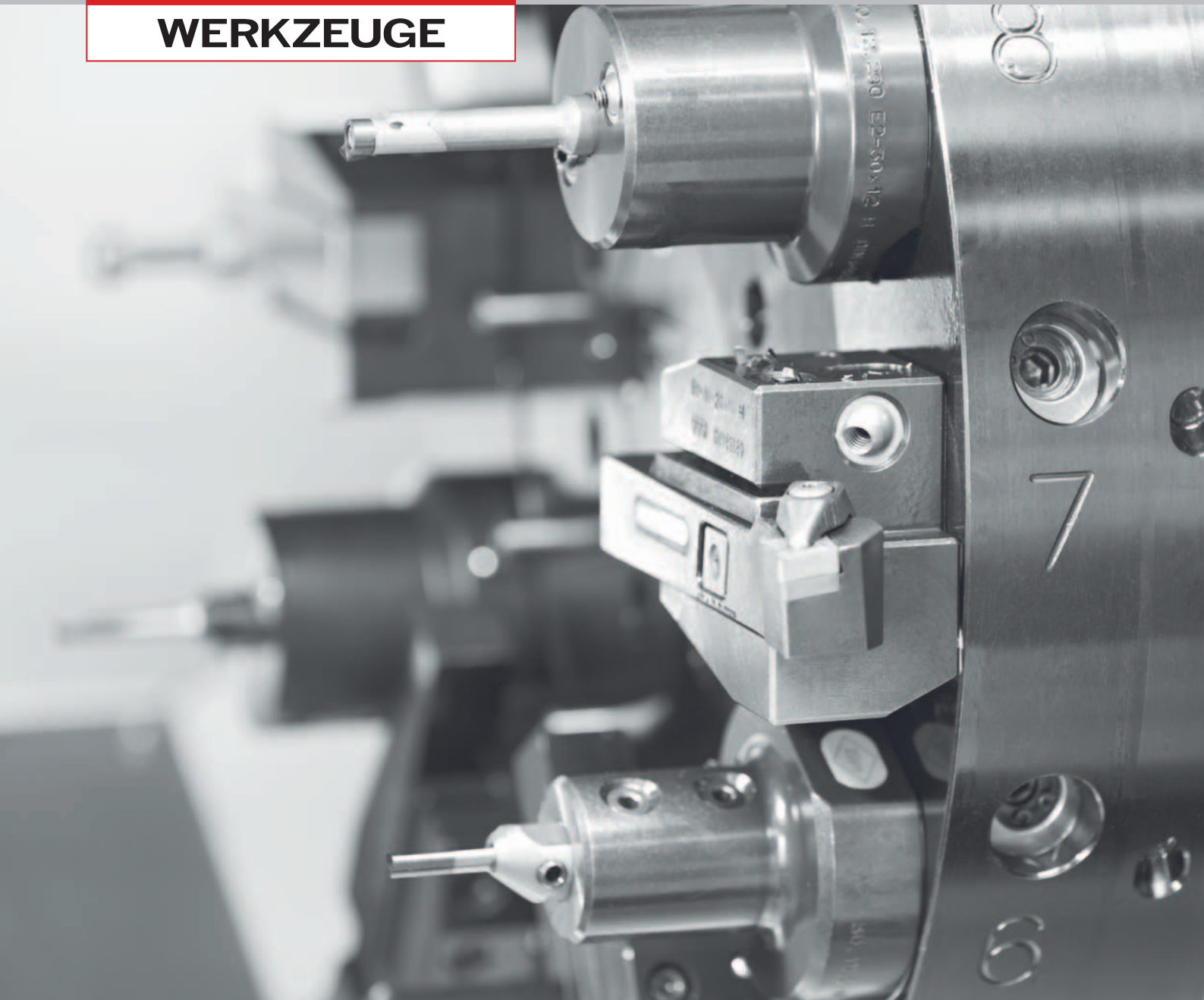

Grooving

Whether it is radial or axial grooving, parting off, groove turning or internal grooving, you will find the ideal tool from ARNO-Werkzeuge.

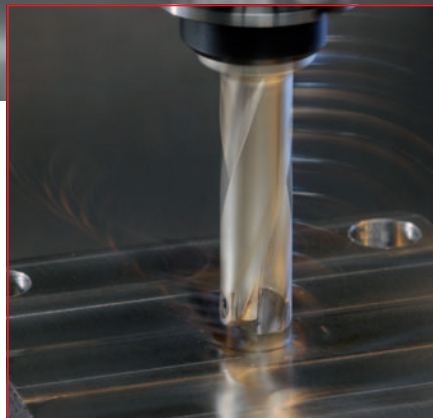

Drilling

From 1 mm to 114 mm diameter you will find a solid carbide drill or a solution with indexable inserts from our extensive product range.



Turning

ARNO-Werkzeuge offers reliable tools utilizing various inserts for your most demanding internal or external machining applications as well as tools and inserts for threading.

Strength from experience, competence and development.

“For the future you need a partner with future.”

By working closely with partners inside and outside the company, we are very capable of satisfying individual requirements which often lead to special tooling. These tools are consistently improved and might find their way into our standard portfolio of catalogue tooling later.

New materials and expectations of constant improvement of machine time, motivate us to research and develop new tooling and cutting tool materials. That means developing modular tooling systems that are modified for each individual application. Our high performance but still affordable solutions include our extensive range of drilling systems, grooving systems, milling cutters and our huge range of indexable inserts (not just for turning) as well as tool holding and vending solutions.

Our technical support and advice follow any of our high quality tools. **Our highly competent team will support you with service even after you have made your decision to purchase.**



Milling

Face-mills, square shoulder-mills, chamfer-mills, milling cutters with round inserts, roughing cutters and solid carbide cutters. We have the right cutter for your application.



Tool Vending

Secure storage, monitoring and usage reporting guaranteed with our highly flexible StoreManager solution.



Work Holding Equipment

NC-machine vice in various executions of number of jaws and widths ensure maximum component clamping for the modern manufacturing.

ARNO[®]

WERKZEUGE

0

Service to Size.

Individual solutions

Despite our wide range of standard tools which will cover a majority of applications, sometimes you may just need a solution for a specific request. ARNO can offer you a special tool which suits your application exactly. A perfect solution without any compromises.

Overnight delivery

When urgency is required ARNO is there to help. Place your order for standard tools by 3:30 PM CET and our tools could be on your machine the next day. For special solutions we need a little longer but then you will also be getting a high quality tool just for your application.

Everything under one roof

The high quality of our products is a result of having R&D, manufacturing and sales at one location. This also gives us the opportunity for testing, offering faster response time, better control and better prices.

Experienced external sales team

You are never left alone with an ARNO product. Our experienced external ARNO sales team is always available for service and support.

Our application engineers

When you have a problem with an application our application engineers will be available to advise you on technical issues.

Ordering hotline

Wherever you may be in the world you will be able to contact an ARNO representative. Take advantage of our competence, we look forward to being of service.

Globally available – Service where you need it.

ARNO-Werkzeuge is represented world wide. It is important to us that we can service you where you need it. Our distributors and sister companies are always local and easy to contact.

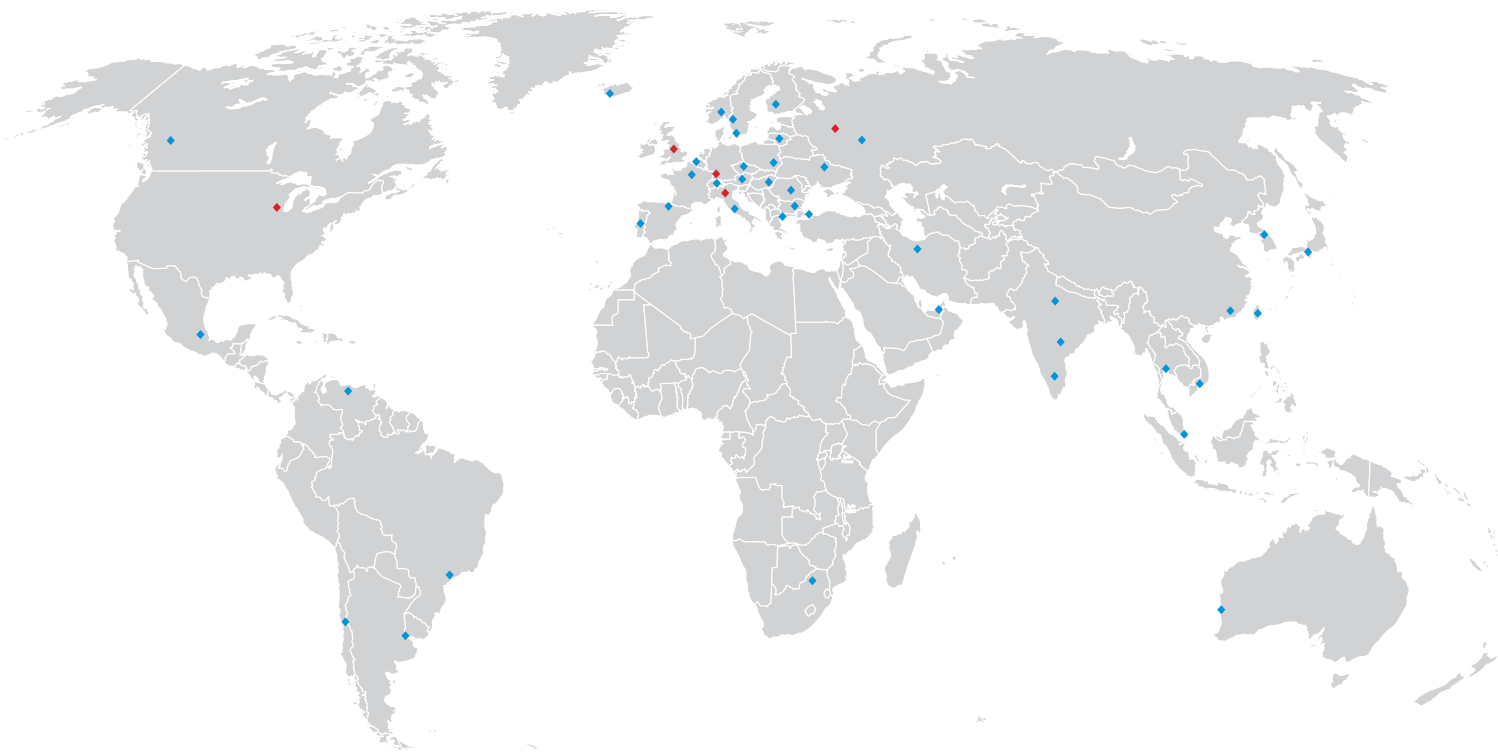

◆ ARNO location

◆ Distributor

Karl-Heinz Arnold GmbH
Karlsbader Str. 4
73760 Ostfildern

Tel.: +49 (0) 711/34 802-0
Fax: +49 (0) 711/34 802-130
info@arno.de
www.arno.de

ARNO (UK) Limited | Unit 3, Sugnall Business Centre | Sugnall, Eccleshall | Staffordshire | ST21 6NF
☎ +44 01785 850 072 | 📠 +44 01785 850 076 | sales@arno.de | www.arno-tools.co.uk

ARNO Italia S.r.l | Via J. F. Kennedy 19 | 20871 Vimercate (MB)
☎ +39 039 68 52 101 | 📠 +39 039 60 83 724 | info@arno-italia.it | www.arno-italia.it

ARNO-Werkzeuge USA LLC | 1101 W. Diggins St. | US-60033 Harvard, Illinois
☎ +1 815 943 4426 | 📠 +1 815 943 7156 | info@arnousa.com | www.arnousa.com

ARNO RU Ltd. | Krassnaja Ul. 38 | RU-600015 Vladimir
☎/📠 +7 4922 541125 | 📞 +7 4922 541135 | info@arnoru.ru | www.arnoru.ru



Page 29

ARNO®-FTA face milling system

The universal face milling system for cost reduction!



Page 45

ARNO®-Duo-Mill milling system

Square shoulder and high feed (HFC) milling with just one tool!



Page 87

ARNO®-Milling system ROC-Mill

The soft cutting positive face mill which accepts both round and octagonal inserts in the same insert pocket.

The art of milling.

Milling is a considerable part of the overall metal cutting market and in order to achieve the best possible results the demand for performance tooling is high.

High tech with high precision.

Long tool life, new materials, ever increasing customer demands – expectations especially for cutting tools for metal removing are high.

A challenge we are happy to take. It is our aim to exceed expectations. With a constantly developing range of new and modern cutting tools and geometries we are setting the new standards.



Page 107

Milling

Face-mills, square shoulder-mills, chamfer-mills, milling cutters with round inserts, roughing cutters and solid carbide cutters. We have the right cutter for your application.

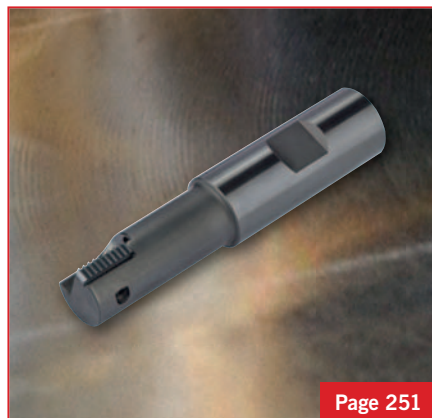

Page 251

Thread milling

Holders and inserts for milling different types of thread. For ISO thread milling we have solutions available from M1,6 to M300.



Catalogue Special prices

Solid carbide milling and thread milling cutters

In the Special Price catalogue you will find our full range of solid carbide milling cutters suitable for nearly all materials and applications.

ARNO®

WERKZEUGE



1962

Karl-Heinz Arnold fonda il primo aprile la Karl-Heinz Arnold Werkzeuge. Obiettivo: commercio di utensili in metallo duro.

1965

La Emil Arnold diventa Emil Arnolds KG. Obiettivo: produzione di utensili speciali e dispositivi per macchine speciali oltre che la produzione in serie di utensili di serraggio.

1979

La Emil Arnold dopo uno sviluppo durato un anno mette sul mercato il nuovo sistema di copiatura mini con un nuovo sistema di bloccaggio brevettato.

1941

Emil Arnold, responsabile alla Bosch si rende indipendente e fonda la Emil Arnold ad Esslingen in via Franziskaner 7.

1966

Trasferimento di entrambe le aziende nella zona industriale di Ostfildern vicino a Stoccarda.

1967

Inizio della vendita di inserti in metallo duro per Fresatura e fresatura.

1981

Ulteriore sviluppo di propri utensili sul mercato per es. il sistema di scanalatura NC.

1989

Sviluppo della tecnica di affilatura.

Tradizione e precisione.

“Da un’impresa familiare a impresa a livello mondiale.”

1941 Emil Arnold fonda l'azienda ad Esslingen am Neckar. La produzione iniziale è dedicata alla costruzione di strumenti di misura e controllo. L'azienda è riconosciuta per la qualità dei propri prodotti e per la soddisfazione presso i propri clienti.

Insieme al figlio Karl-Heinz Arnold alla continua ricerca di innovazioni e sviluppi. Ha l'obiettivo di vendere i suoi utensili in tutti i Paesi e in tutti i rami dell'industria. Nel 1962 suo figlio fonda la Karl-Heinz Arnold GmbH che successivamente col nome di ARNO-Werkzeuge si dedicherà al commercio di gli utensili in metallo duro.

1987 Klaus-Michael Arnold inizia la sua esperienza in azienda e nel 1992 ne acquisisce la proprietà. Insieme a Josef Storf, nominato amministratore nel 2002, si pone nuovi obiettivi e definisce le basi per lo sviluppo di nuovi prodotti. Nel 2004 viene aperta la prima filiale in Inghilterra. Subito dopo seguono Italia, Stati Uniti e Russia. La distribuzione dei prodotti viene oggi garantita in tutto il mondo grazie ad una capillare distribuzione e ad un efficiente servizio.

2002

Espansione dell'affilatura. Trasferimento nella nuova sede.

2004

Viene fondata la filiale nel Regno Unito.

2006

Viene fondata la filiale in Italia.

2009

Vengono fondate filiali in USA e Russia. Costruzione di un nuovo centro logistico a Ostfildern.

2010

Alla AMB vengono presentati nuovi prodotti: sistema di scanalatura SA, ARNO Mini-Sytem, SIM, il sistema di fresatura FTA, Duo-Mill e Roc-Mill.

2012

Viene presentata sul mercato la punta AKB e nuovi inserti Shark-Drill² allargano la gamma.



1995

Certificazione di Emil Arnold GmbH & Co KG secondo DIN ISO 9002. Certificazione ARNO-Werkzeuge secondo DIN EN ISO 9001.

ARNO®

WERKZEUGE

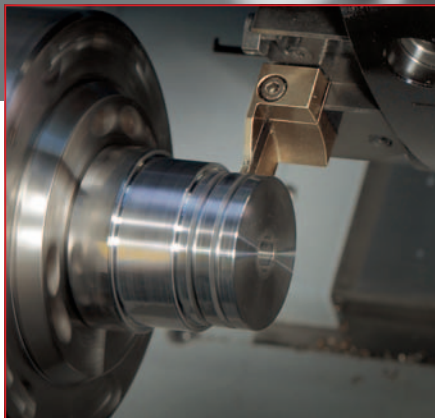
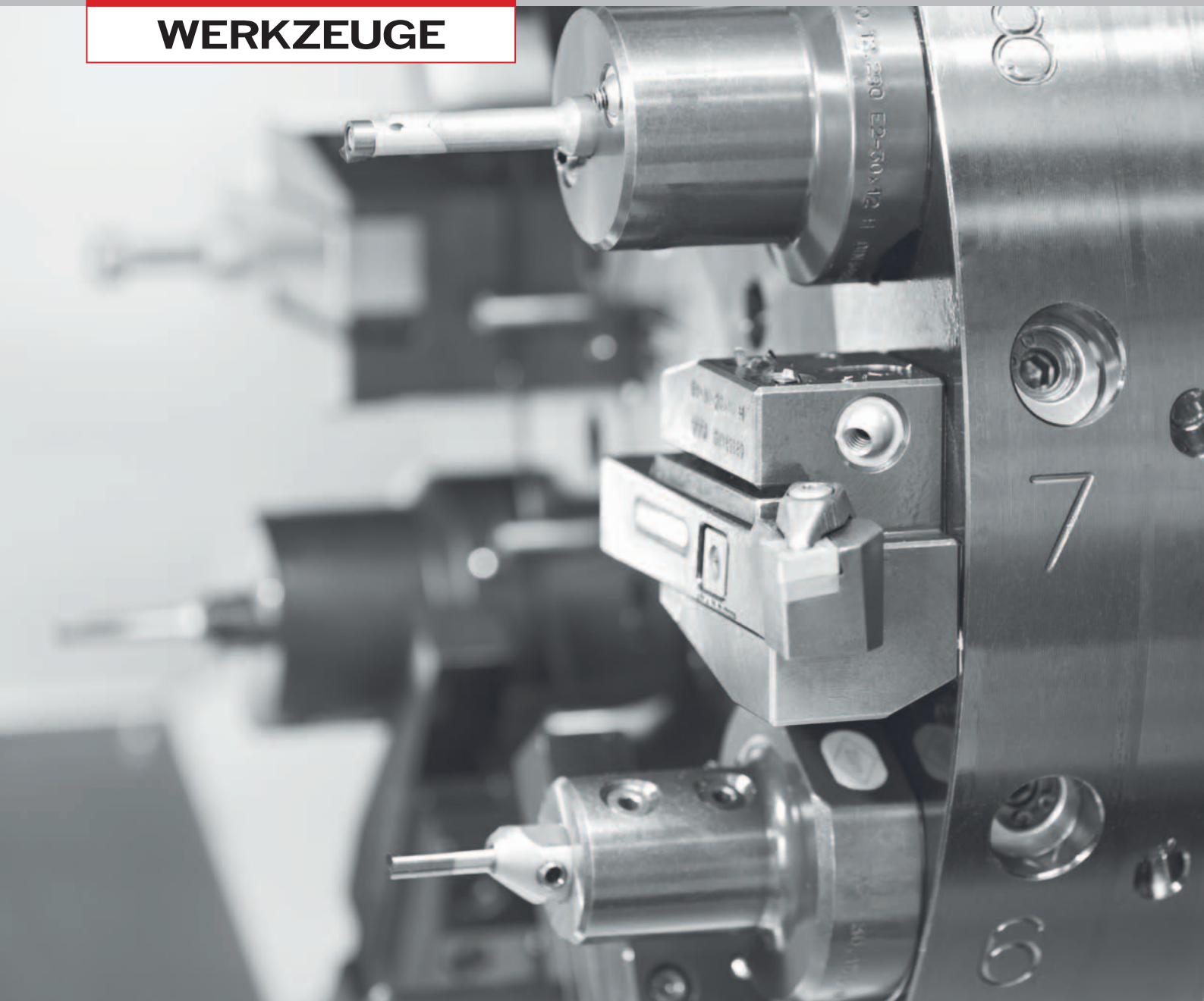

Scanalatura

Con ARNO-Werkzeuge troverete il giusto utensile per ogni tipo di scanalatura: radiale, assiale, interna.

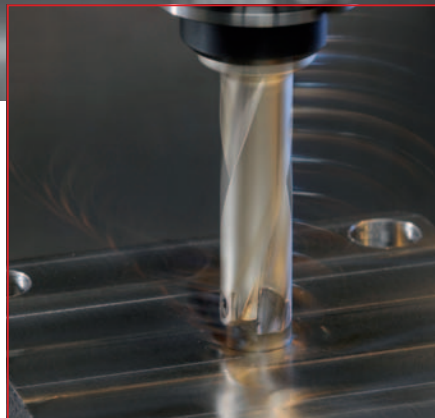

Foratura

Nella nostra gamma prodotti troverete punte in HSS, Metallo duro, ad inserti e a cuspidi per diametri da 1 mm a 114 mm.



Tornitura

ARNO-Werkzeuge offre utensili affidabili con diversi inserti per le migliori prestazioni di lavorazione interna od esterna.

Forza grazie all'esperienza, competenza e sviluppo.

“Per il futuro avete bisogno di un partner con un futuro.”

Grazie all'intensiva collaborazione dentro e fuori dall'azienda siamo in grado di esaudire ogni richiesta del cliente. Per questo siamo alla ricerca continua di prodotti da sviluppare da aggiungere alla nostra ampia gamma prodotti.

Nuovi materiali e nuove condizioni di lavorazione ci spingono a sviluppare nuovi prodotti da lanciare sul mercato come utensili modulari che possono essere adattati alle singole esigenze. La nostra gamma di prodotti spazia dalla foratura, alla scanalatura e fresatura, tornitura ad inserti, oltre a sistemi di bloccaggio e distributori automatici di utensili.

Oltre ai prodotti di qualità offriamo anche competenza e consulenza. Il nostro team esaudirà le vostre richieste e vi guiderà nella scelta.



Fresatura

Fresatura piana, circolare, sgrassatura anche per queste applicazioni abbiamo l'utensile giusto.



Distributori di utensili

Lo StoreManager garantisce sicurezza e flessibilità.



Bloccaggio utensili

Morse NC semplici o doppie per un bloccaggio ottimale del pezzo.

ARNO[®]

WERKZEUGE

0

Servizio di qualità.

Soluzioni speciali individuali

Con la nostra vasta gamma di prodotti siamo attrezzati per ogni richiesta. Avete bisogno di un utensile particolare per una lavorazione particolare? Rivolgetevi a noi e vi forniremo un prodotto studiato su misura per voi. Risultati perfetti senza limiti!

Consegna in 24 ore

Avete fretta? Nessun problema, poiché se riceviamo i vostri ordini entro le 15:30 garantiamo la consegna il giorno successivo. Le situazioni di disponibilità dei prodotti standard sono visibili da tutti i nostri clienti tramite un innovativo accesso WEB.

Tutto sotto lo stesso tetto

L'elevata qualità dei nostri prodotti è garantita dal fatto che la progettazione, la produzione e la distribuzione avvengono in un unico posto. Ciò permette tempistiche veloci, miglior controllo prezzo favorevole.

Un grande team

Non vi lasciamo soli. Il nostro team vi visiterà regolarmente e vi supporterà nella scelta del prodotto più adatto a voi.

I nostri tecnici

Avete una domanda o problemi di lavorazione? I nostri tecnici vi visiteranno e risponderanno ad ogni vostro quesito.

Ordini Hot Line

Avete la possibilità di raggiungere un collaboratore ARNO in tutto il mondo. Approfittate del nostro help desk telefonico. Tecnici professionali sono a vostra completa disposizione.

Utilizzati nel mondo, assistenza sul posto.

Potete trovare gli utensili ARNO in tutto il mondo. Per noi è importante offrire un servizio localizzato e grazie alle filiali e i vari partner commerciali siamo in grado di raggiungervi in tutto il mondo.

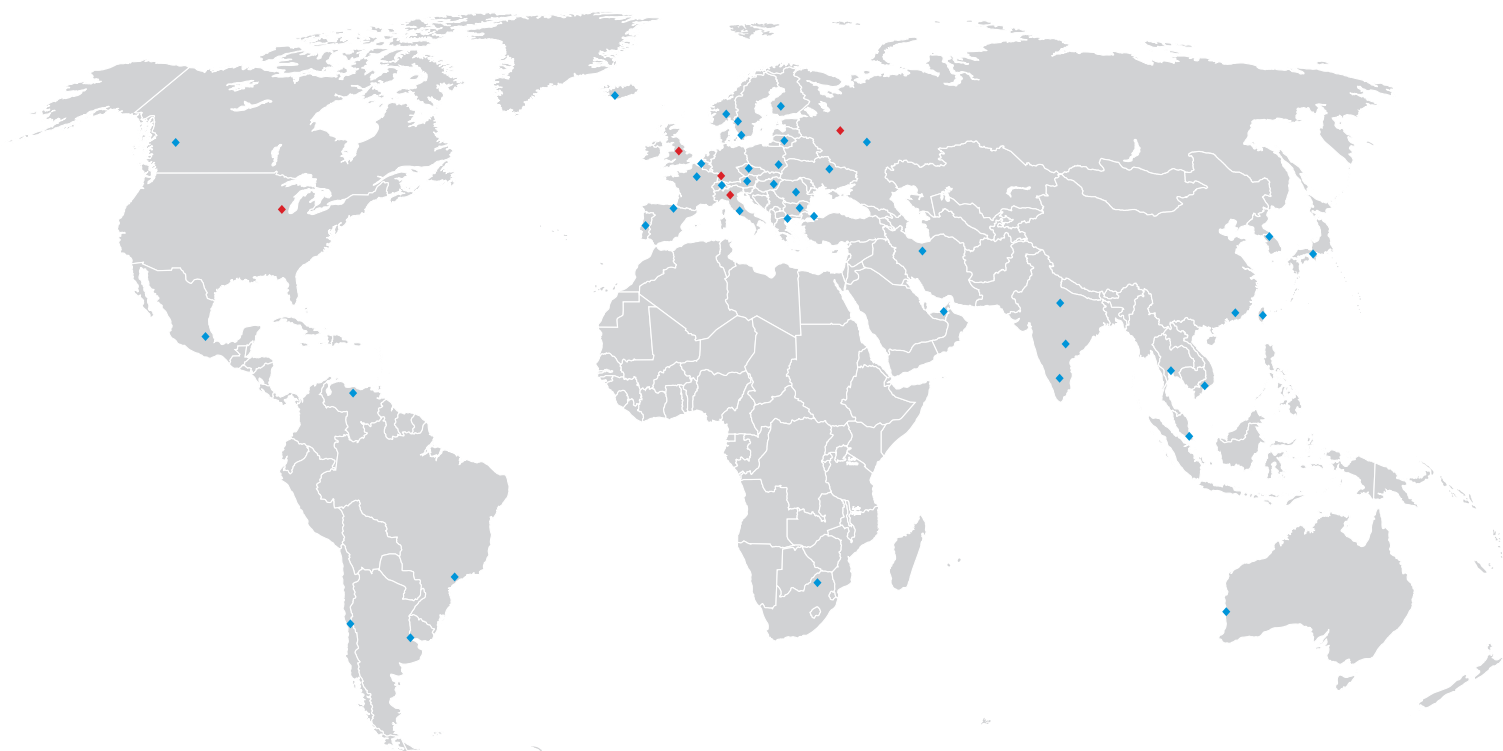

◆ Filiali

◆ Partner commerciali

Karl-Heinz Arnold GmbH
Karlsbader Str. 4
73760 Ostfildern

Tel.: +49 (0) 711/34 802-0
Fax: +49 (0) 711/34 802-130
bestellung@arno.de
anfrage@arno.de
www.arno.de

ARNO (UK) Limited | Unit 3, Sugnall Business Centre | Sugnall, Eccleshall | Staffordshire | ST21 6NF
☎ +44 01785 850 072 | 📠 +44 01785 850 076 | sales@arno.de | www.arno-tools.co.uk

ARNO Italia S.r.l | Via J.F. Kennedy 19 | 20871 Vimercate (MB)
☎ +39 039 68 52 101 | 📠 +39 039 60 83 724 | info@arno-italia.it | www.arno-italia.it

ARNO-Werkzeuge USA LLC | 1101 W. Diggins St. | US-60033 Harvard, Illinois
☎ +1 815 943 4426 | 📠 +1 815 943 7156 | info@arnousa.com | www.arnousa.com

ARNO RU Ltd. | Krassnaja Ul. 38 | RU-600015 Vladimir
☎ / 📠 +7 4922 541125 | 📠 +7 4922 541135 | info@arnoru.ru | www.arnoru.ru

ARNO®

WERKZEUGE



da pagina 29

ARNO®-Sistema di fresatura FTA

Il sistema universale sviluppato per una riduzione dei costi di lavorazione!



da pagina 45

ARNO®-Sistema di fresatura Duo-Mill

Spallamento retto e fresatura ad alto avanzamento con un solo corpo fresa!



da pagina 87

ARNO®-Sistema di fresatura ROC-Mill

Una fresa a taglio positivo sulle cui sedi è possibile montare sia un inserto ottagonale che un inserto tondo!

L'arte della fresatura

La fresa è un componente fondamentale nella tecnica di produzione e lavorazione dei metalli per la realizzazione di forme e sagome richieste. Per raggiungere i migliori risultati possibili è pertanto richiesta la maggior precisione.

High-tech con la migliore precisione.

Lunga durata, nuovi materiali, esigenze dei clienti sempre maggiori; le aspettative nei confronti degli utensili da taglio per la lavorazione dei metalli crescono costantemente.

Una sfida che noi accettiamo volentieri. Il nostro obiettivo è di superare le aspettative. Con una gamma di nuovi utensili ed in costante sviluppo, tecniche di lavorazione ultramoderne e geometrie di taglio ottimizzate definiamo nuovi standard di lavorazione.



da pagina 107

Fresatura

Fresatura piana, circolare, sgrossatura; anche per queste applicazioni abbiamo l'utensile giusto.



da pagina 251

Fresatura di filettatura

Utensili ed Inserti per la fresatura di filetti di varie tipologie. Per filettature ISO sono disponibili soluzioni da M1,6 a M300.



Catalogo promozione

Frese e frese a filettare in M.D.I.

Nel Catalogo Promozione troverete la nostra gamma completa di frese in metallo duro adatte per quasi tutti i materiali e applicazioni.

Innenkühlung / Through tool coolant / Adduzione interna del refrigerante



Anwendung / Application / Applicazione

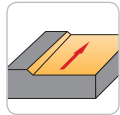

Planfräsen
Face milling
Spianatura

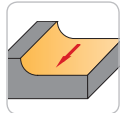

Planfräsen Rund WSP
Face milling with round inserts
Spianatura inserti tondo

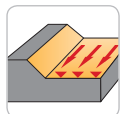

Schlichtfräsen
Finishing
Finitura

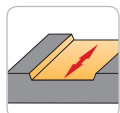

Gassenfräsen
Slot milling
Fresatura di cave

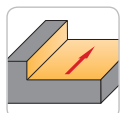

Eckfräsen
Square shoulder milling
Fresatura a spallamento retto

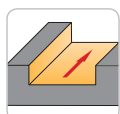

Nutfräsen
Slot milling
Fresatura per cave

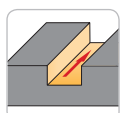

Nutfräsen (Schafffräsen/Scheibenfräsen)
Slot milling (End mill/Side and face cutter)
Fresatura per cave (Fresa cilindrica/Frese per scanalature)

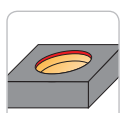

Entgraten
Deburring
Smussare



Besäumen
Contour milling
Fresatura in contornatura

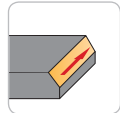

Fasen
Chamfering
Fresatura a smussi

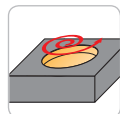

Zirkularfräsen
Circular milling
Fresatura circolare

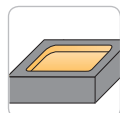

Taschenfräsen
Face milling
Fresatura assiale

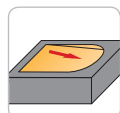

Rampe eintauchen
Ramping
Fresatura in rampa

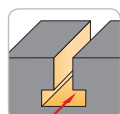

T-Nut fräsen
T-slot milling
Fresatura con frese per cave a T

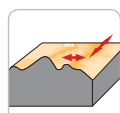

Kopierfräsen
Copy milling
Fresatura di copiatura

Sonstige / Other / Altro



**ARNO®-
Frässystem FTA**

- Systemvorstellung
- Bezeichnungssystem
- Werkzeugauswahl
- Trägerwerkzeuge
- Wendeschneidplatten
 - Geometriebeschreibung
 - Sortenbeschreibung
- Werkzeugaufnahmen
- Ersatzteile
- Schnittwerte
- Anwendungshinweise

**ARNO®-
FTA milling system**

- *System introduction*
- *Designation system*
- *Tool shank options*
- *Holders*
- *Indexable inserts*
 - *Geometry description*
 - *Grade description*
- *Adaptors*
- *Spare parts*
- *Cutting data*
- *Application reference*

**ARNO®-
Sistema di fresatura FTA**

- Caratteristiche del sistema **30 – 31**
- Sistema di numerazione **32**
- Tipologie di attacco utensile **33**
- Corpi fresa **34**
- Inserti **35 – 37**
 - Descrizione delle Geometrie **35**
 - Descrizione delle Qualità **36**
- Attacchi **38**
- Ricambi **39**
- Parametri di taglio **40 – 43**
- Suggerimenti tecnici **44**



ARNO®-Frässystem FTA zum Planfräsen

ARNO®-FTA face milling system

ARNO®-Sistema di fresatura FTA di Spianatura

1

Hohe Fertigungsgenauigkeit (Rund- und Planlauf gemessen auf Meisterplatte 0,02 mm)

High accuracy (axial and radial runout of 0.02 mm)

Elevata precisione di costruzione sede inserto (+/- 0,02 mm)

Geringer Leistungsbedarf für maximales Zeitspanvolumen

Low power requirement

Geometrie di taglio positive per ridotte forze di taglio e massimo volume truciolo

Weite und enge Teilung

Coarse and close pitch

Passo largo e passo stretto

Planfräser mit 45° Anstellwinkel, Durchmesser von 40 mm – 250 mm

Face mill with 45° approach angle, diameter 40 mm – 250 mm

Fresatura di spianatura a 45° per diametri di lavoro da 40 a 250 mm

Integrierte Kühlmittelbohrungen, geeignet für Minimalmengenschmierung (MMS)

Integral through tool coolant, suitable for minimum quantity lubrication (MMS)

Adduzione interna del refrigerante con canali diretti sul tagliente per una ottimale refrigerazione. Idoneo anche per la refrigerazione minimale (MQL)

Vernickelte Werkzeuggrundkörper

Nickel plated milling cutter body

Rivestimenti antiusura di Nickel del corpo



Fakten

- **Höchst stabile Wendeschneidplatte dank negativer Grundform**
- **Wendeschneidplatte mit effektiv 8 Schneidkanten**
- **In 5 verschiedenen Hartmetallsorten erhältlich**
- **Weicher Schnitt durch positive Spanformgeometrie**
- **Sehr hohe Laufruhe – dadurch maximale Spindelschonung**
- **Ungleichteilung – Reduzierung von Resonanzschwingungen**
- **Optimales Preis-/Leistungsverhältnis**

Features

- *Extremely strong indexable insert due to negative design*
- *Precision sintered indexable insert with 8 effective cutting edges*
- *Available in 5 carbide grades*
- *Soft cutting geometry*
- *Very smooth cutting action and therefore reduced spindle wear*
- *Unequal pitch for reduced vibration*
- *Excellent price and performance*

Caratteristiche

- Insetto molto robusto dato dalla forma Negativa
- Insetto sinterizzato di elevata precisione con 8 taglienti effettivi
- Taglio dolce grazie alla geometria positiva degli inserti
- Minor potenza richiesta al mandrino grazie alle ridotte forze di taglio
- Allineamento preciso degli inserti per un taglio più uniforme
- Passo differenziato delle sedi inserto per ridurre le vibrazioni
- Molto valido per il taglio di acciai generici
- Eccellente rapporto Qualità / Prezzo



Trägerwerkzeuge / Holders / Porta utensili

1

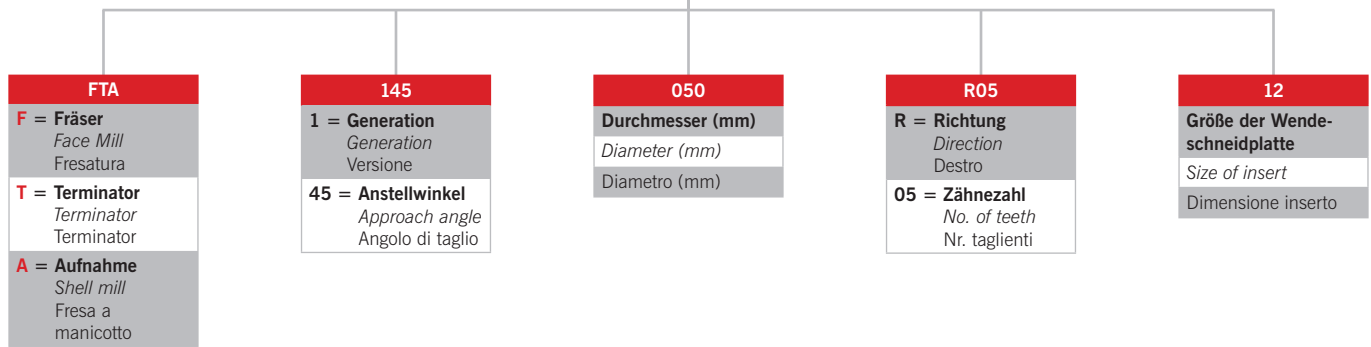

Wendeschneidplatten / Indexable Inserts / Inserti

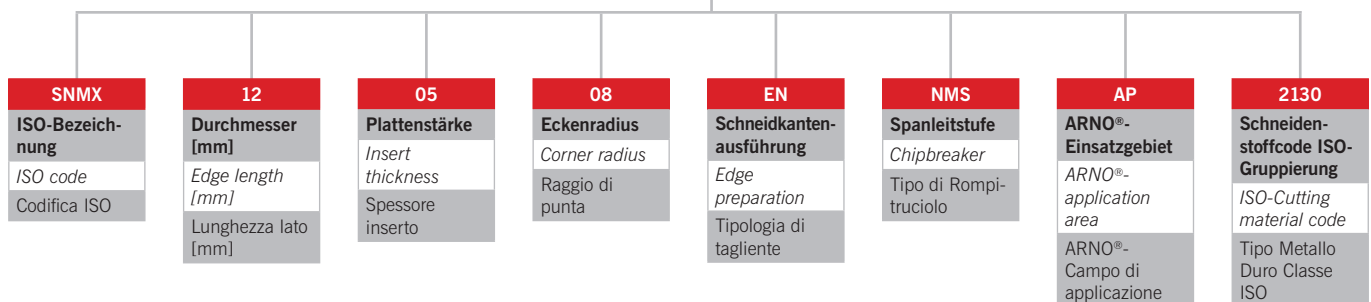



Trägerwerkzeuge

Holder
Corpi fresa

Seite/Page/Pagina **34**



Wendescheidplatten

Indexable inserts
Inserti

Seite/Page/Pagina **37**

1

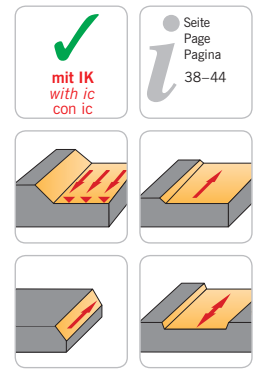
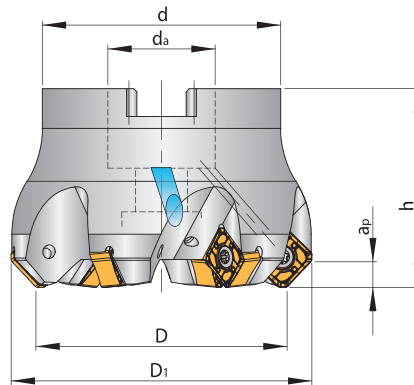

Planfräser / Face milling cutter / Frese per spianatura – FTA

Bezeichnung Designation Articolo	D	D ₁	h	d	d _a	a _p	z	Wendeschneidplatte Indexable insert Inserto
FTA-145.040.R03-12	40	52,6	50	40	22	6	3	SN..X 1205...
FTA-145.040.R04-12	40	52,6	50	40	22	6	4	SN..X 1205...
FTA-145.050.R04-12	50	62,7	50	48	27	6	4	SN..X 1205...
FTA-145.050.R05-12	50	62,7	50	48	27	6	5	SN..X 1205...
FTA-145.063.R05-12	63	75,8	50	60	27	6	5	SN..X 1205...
FTA-145.063.R06-12	63	75,8	50	60	27	6	6	SN..X 1205...
FTA-145.080.R06-12	80	92,7	50	78	32	6	6	SN..X 1205...
FTA-145.080.R08-12	80	92,7	50	78	32	6	8	SN..X 1205...
FTA-145.100.R08-12	100	112,8	50	90	40	6	8	SN..X 1205...
FTA-145.100.R10-12	100	112,8	50	90	40	6	10	SN..X 1205...
FTA-145.125.R10-12	125	137,8	50	90	40	6	10	SN..X 1205...
FTA-145.125.R12-12	125	137,8	50	90	40	6	12	SN..X 1205...
FTA-145.160.R14-12*	160	172,7	60	104	40	6	14	SN..X 1205...
FTA-145.200.R16-12*	200	212,7	60	160	60	6	16	SN..X 1205...
FTA-145.250.R20-12*	250	262,7	60	160	60	6	20	SN..X 1205...

* ohne Innenkühlung
* without internal coolant
* senza adduzione interna

- ALU

Für die Zerspanung von Aluminium und NE-Metallen.



- ALU

For machining aluminium, aluminium alloys and non-ferrous materials.

Schlicht- bis Schrumpferspanung

Finishing to roughing
Finitura e sgrassatura

zweiseitig
double sided
doppio lato



- ALU

Per la lavorazione di alluminio e materiali non ferrosi.

- NMG

Geometrie für die Zerspanung von Gusswerkstoffen.

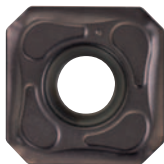

- NMG

Geometry for machining cast materials.

Mittlere bis grobe Zerspanung

Medium to rough cutting
Sgrassatura da media a pesante

zweiseitig
double sided
doppio lato

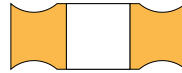

- NMG

Geometria per la lavorazione di ghisa.

- NMR

Zur Bearbeitung rostfreier Stähle.

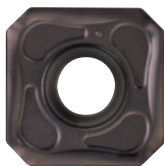

- NMR

For machining stainless steels.

Mittlere bis grobe Zerspanung

Medium to rough cutting
Sgrassatura da media a pesante

zweiseitig
double sided
doppio lato

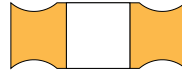

- NMR

Per la lavorazione di acciaio inox.

- NMS

Geometrie für die Stahlbearbeitung.

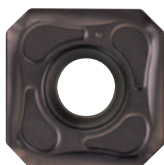

- NMS

Geometry for machining steel.

Mittlere bis grobe Zerspanung

Medium to rough cutting
Sgrassatura da media a pesante

zweiseitig
double sided
doppio lato

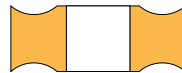

- NMS

Geometria per la lavorazione dell'acciaio.

Hartmetall beschichtet / Carbide grade coated / Metallo duro rivestito**AK2115**

CVD-beschichtete Hartmetallsorte.
Geeignet für die mittlere Bearbeitung und zum Schruppen von Grauguss. Hauptsächlich für die Trockenbearbeitung bei mittleren bis hohen Schnittgeschwindigkeiten.

*CVD-coated carbide grade.
Suitable for medium machining of cast iron.
Mainly to be used for dry cutting at medium to high cutting speed.*

Qualità di metallo duro con rivestimento multistrato CVD.
Progettata per asportazioni medie e di sgrossatura di ghisa grigia. Adatta alla lavorazione a secco a medie ed elevate velocità di taglio.

AM5740

PVD-beschichtete Hartmetallsorte.
Zum Fräsen von rostfreiem Stahl bei mittleren und hohen Schnittgeschwindigkeiten. In Kombination mit der positiven Schneidengeometrie auch zum Fräsen von warmfesten Legierungen und Titanlegierungen möglich.

*PVD-coated carbide grade.
For milling stainless steel at medium to high cutting speed. Due to the positive geometry also suitable for milling high temperature alloys and titanium alloys.*

Qualità di metallo duro con rivestimento multistrato PVD.
Studiata appositamente per la fresatura di acciai inossidabili con medie ed elevate velocità di taglio. In combinazione con la geometria di taglio positiva, risulta idoneo anche alla lavorazione di leghe refrattarie e leghe di Titanio.

AP2130

CVD-beschichtete Hartmetallsorte.
Optimiert für beste Produktivität beim Fräsen von Stahl. Besonders geeignet zur wirtschaftlichen Trockenbearbeitung. Hohe Bearbeitungssicherheit kombiniert mit guter Verschleißfestigkeit zeichnet diese Sorte aus.

*CVD-coated carbide grade.
Main grade for milling steel. Well suited for dry milling. High productivity and wear resistance.*

Qualità di Metallo duro Rivestita CVD.
Ideale per la lavorazione di acciai. Particolarmente adatto per lavorazioni a secco. Buona affidabilità data dal compromesso tra tenacità e resistenza all'usura.

AP5230

PVD-beschichtete Hartmetallsorte.
Geeignet zum Schlichten von Stählen, rostfreien Stählen und Gusswerkstoffen. Eine sehr universell einsetzbare Sorte mit hoher Hitze- und Oxidationsbeständigkeit.

*PVD-coated carbide grade.
Suitable for finishing steel, stainless steel and cast materials. A very universal grade with high heat and oxidation resistance.*

Qualità di metallo duro con rivestimento PVD.
Adatto per la finitura di acciai, acciai inossidabili e Ghisa. Un grado universale molto versatile ad alte temperature e per leghe resistenti all'ossidazione.

Hartmetall unbeschichtet / Carbide grade uncoated / Metallo duro non rivestito**AN1015**

Unbeschichtete Hartmetallsorte zum Schlichten und Schruppen von Aluminiumlegierungen und bei NE-Metallen in Verbindung mit geschliffenen Schneidkanten. Zur Reduzierung der Aufbauschneidenbildung ist die Spanfläche hochglanzpoliert.

Uncoated carbide grade for roughing and finishing of aluminium alloys and with its sharp edge also for non-ferrous materials.

Qualità di metallo duro non rivestita per la finitura e la sgrossatura di leghe non ferrose e di alluminio.

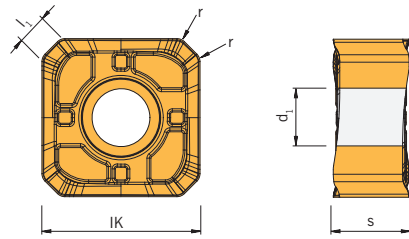

SNMX



Bezeichnung Designation Articolo	IK	l ₁	s	d ₁	r	PVD beschichtet coated rivestito		CVD beschichtet coated rivestito		unbeschichtet uncoated non rivestito
						AM5740	AP5230	AP2130	AK2115	AN1015
SNMX 120508EN-NMS	12,0	2,0	5,56	4,4	0,8			●		
SNMX 120508EN-NMR	12,0	2,0	5,56	4,4	0,8	●				
SNMX 120508EN-NMG	12,0	2,0	5,56	4,4	0,8				●	

- **Hauptanwendung**
Main application
Applicazione principale
- **Nebenanwendung**
Secondary application
Applicazione secondaria

	P	M	K	N	S	H
AM5740		●			○	
AP5230		●	●			
AP2130	●					
AK2115			●			
AN1015						●

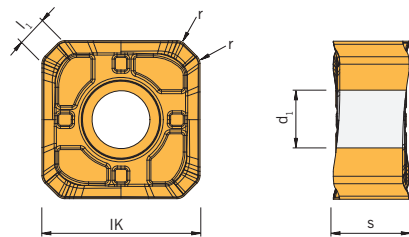

SNGX



Bezeichnung Designation Articolo	IK	l ₁	s	d ₁	r	PVD beschichtet coated rivestito		CVD beschichtet coated rivestito		unbeschichtet uncoated non rivestito
						AM5740	AP5230	AP2130	AK2115	AN1015
SNGX 120508FN-ALU	12,0	2,0	5,56	4,4	0,8					●
SNGX 1205ZZ *	12,0	2,0	5,56	4,4	235		●			

- * **Breitschichtplatte**
- * **Wiper insert**
- * **Inserto raschiante**

- **Hauptanwendung**
Main application
Applicazione principale
- **Nebenanwendung**
Secondary application
Applicazione secondaria

	P	M	K	N	S	H
AM5740		●			○	
AP5230	●	●	●			
AP2130	●					
AK2115			●			
AN1015						●

Adaptors
Attacchi

Werkzeugaufnahme SK40 für FTA Fräser

SK40 face mill adaptors for FTA cutters

Attacchi SK40 per Frese

Fräser-Ø Cutter-Ø D Fresa	L	Werkzeugaufnahme Adaptor Attacco SK40 DIN 69871	Werkzeugaufnahme Adaptor Attacco SK40 MAS BT
[mm]	[mm]	Bezeichnung Designation Articolo	Bezeichnung Designation Articolo
40	50	69871AD+B-40-22x40IK-L50	BT40AD+B-22x40IK-L50
50	50	69871AD+B-40-27x48IK-L50	BT40AD+B-27x48IK-L50
63	50	69871AD+B-40-27x60IK-L50	BT40AD+B-27x60IK-L50
80	60	69871AD+B-40-32x78IK-L60	BT40AD+B-32x78IK-L60
100	60	69871AD+B-40-40x90IK-L60	BT40AD+B-40x90IK-L60
125	60	69871AD+B-40-40x90IK-L60	BT40AD+B-40x90IK-L60



Werkzeugaufnahme HSK63 für FTA Fräser

HSK63 face mill adaptors for FTA cutters

Attacchi HSK63 per Frese

Fräser-Ø Cutter-Ø D Fresa	L	Werkzeugaufnahme Adaptor Attacco SK40 DIN 69871
[mm]	[mm]	Bezeichnung Designation Articolo
40	50	HSK-A63-22x40IK-L50
50	60	HSK-A63-27x48IK-L60
63	60	HSK-A63-27x60IK-L60
80	60	HSK-A63-32x78IK-L60
100	60	HSK-A63-40x90IK-L60
125	60	HSK-A63-40x90IK-L60



Schrauben und Schraubendreher

Screws and Screwdrivers

Chiavi e Viti

Bezeichnung Designation Articolo	Drehmoment Torque Forza di serraggio	TorxPlus®-Spanschraube TorxPlus®-Screw TorxPlus®-Vite	TorxPlus®-Schlüssel TorxPlus®-Key TorxPlus®-Chiave
FTA-145.....12	4 Nm	AS 0041	T5115-IP

1

**Hinweis: Drehmoment-Schraubendreher siehe Seite 289.**

Remark: For torque screwdrivers see page 289.

Nota: Chiavi dinamometriche a pagina 289.

FTA – Schnittdatenrichtwerte mit SN.. 1205...

ISO	Werkstoff		Brinell-Härte HB	Schnittgeschwindigkeit V _c [m/min]				
				AP2130	AM5740	AK2115	AN1015	AP5230
P	Unlegierter Stahl und Stahlguss	< 0,15% C / vergütet	125	210–350				250–360
		0,15–0,45% C / vergütet	150–250	170–320				200–320
		> 0,45% C / vergütet	300	150–280				200–300
	Niedrig legierter Stahl und Stahlguss	geglüht	180	150–250				200–280
		vergütet	250–300	140–210				200–280
		vergütet	350	100–180				200–300
	Hochlegierter Stahl, hochlegierter Werkzeugstahl und Stahlguss	geglüht	200	140–210				
vergütet		350	80–170				200–250	
Nichtrostender Stahl		ferritisch, geglüht	200	140–190			200–250	
M	Nichtrostender Stahl	Stahlguss	martensitisch, vergütet	325	100–170			
		ferritisch, martensitisch geglüht	200	90–200	110–240			
		austenitisch, abgeschreckt	180	90–150	85–170		150–250	
		Duplex, abgeschreckt	230	70–180	80–210		150–250	
K	Grauguss	perlitisch/ferritisch	180			230–400	300–400	
		perlitisch/martensitisch	260			180–320	300–400	
	Gusseisen mit Kugelgraphit	ferritisch	160			200–310	250–300	
		perlitisch	–				250–300	
	Temperguss	ferritisch	130			170–240	250–300	
N	Aluminium-Knetlegierungen	nicht aushärtbar	60				< 2000	
		aushärtbar, ausgehärtet	100				< 2000	
	Aluminium-Gusslegierungen	≤ 12% Si, ausgehärtet	80				600–780	
		≤ 12% Si, aushärtbar, ausgehärtet	90				530–600	
		≤ 12% Si, nicht aushärtbar	130				290–350	
	Kupfer und Kupferlegierungen (Bronze / Messing)	Automatenlegierung, Pb > 1%	–				460	
		Messing, Rotguss	–				310	
		Aluminiumbronze	90				200–250	
		Kupfer und Elektrolytkupfer	100				200–300	
	Nichtmetallische Werkstoffe	Duroplaste	100					
Faserverstärkte Kunststoffe		–						
Hartgummi		–						
S	Warmfeste Legierungen	Fe-Basis, geglüht	200		60–75			
		Fe-Basis, ausgehärtet	280		60–65			
		Ni- oder Co-Basis, geglüht	250		60–70			
		Ni- oder Co-Basis 30-58 HRC, gegossen	–		40–60			
		Ni- oder Co-Basis 1500-2200 Nmm ² , ausgehärtet	–					
Titanlegierungen, Alpha+Beta-Legierungen	Rein-Titan	Rm 440		60–75				
	ausgehärtet	Rm 1050		45–60				
H	Gehärteter Stahl	gehärtet und angelassen	55 HRC					
		gehärtet und angelassen	60 HRC					
	Hartguss	gegossen	400					
Gehärtetes Gusseisen	gehärtet und angelassen	55 HRC						

Die Tabellenwerte sind Richtwerte. Es kann notwendig sein, die Werte den jeweiligen Bearbeitungsumständen anzupassen.

FTA – Cutting data recommendation for SN.. 1205...

ISO	Material	Brinell-Hardness HB	Cutting speed V _c [m/min]				
			AP2130	AM5740	AK2115	AN1015	AP5230
P	Unalloyed steel and cast steel	< 0,15% C / hardened and tempered	125	210–350			250–360
		0,15–0,45% C / hardened and tempered	150–250	170–320			200–320
		> 0,45% C / hardened and tempered	300	150–280			200–300
	Low alloyed steel and cast steel	annealed	180	150–250			200–280
		hardened and tempered	250–300	140–210			200–280
		hardened and tempered	350	100–180			200–300
	High alloyed steel, high alloyed tool Steel and cast steel	annealed	200	140–210			
		hardened and tempered	350	80–170			200–250
Stainless steel	ferritic, annealed	200	140–190			200–250	
Cast steel	martensitic, hardened and tempered	325	100–170				
M	Stainless steel	ferritic, martensitic annealed	200	90–200	110–240		
		austenitic, chilled	180	90–150	85–170		150–250
		Duplex, chilled	230	70–180	80–210		150–250
		martensitic/austenitic, chilled	330	70–140	80–160		
K	Cast iron	pearlitic/ferritic	180		230–400		300–400
		pearlitic/martensitic	260		180–320		300–400
	Cast iron with nodular graphite	ferritic	160		200–310		250–300
		pearlitic	–				250–300
	Malleable cast iron	ferritic	130		170–240		250–300
	pearlitic	230		150–220		250–300	
N	Aluminium alloys. long chipping	not heat treatable	60			< 2000	
		heat treatable, heat treated	100			< 2000	
	Casted aluminium alloys	≤ 12% Si, heat treated	80			600–780	
		≤ 12% Si, heat treatable, heat treated	90			530–600	
		≤ 12% Si, not heat treatable	130			290–350	
	Copper and copper alloys, (Brass / Bronze)	Lead alloys, Pb > 1%	–			460	
		Brass, Bronze	–			310	
		Aluminium bronze	90			200–250	
Copper and elektrolyte copper		100			200–300		
Non ferrous materials	Duroplastic	100					
	Re-inforced plastics	–					
	Hard rubber	–					
S	High temperature resistant alloys	Fe-alloyed, annealed	200	60–75			
		Fe-alloyed, heat treated	280	60–65			
		Ni- or Co-alloyed, annealed	250	60–70			
		Ni- or Co-alloyed 30-58 HRC, casting	–	40–60			
		Ni- or Co-alloyed 1500-2200 Nmm ² , heat treated	–				
Titanium alloys	Pure titan	Rm 440	60–75				
Alpha- and Beta-alloys	heat treated	Rm 1050	45–60				
H	Hardened steel	hardened and tempered	55 HRC				
		hardened and tempered	60 HRC				
	Hard cast iron	casting	400				
Hardened cast iron	hardened and tempered	55 HRC					

The data given is only approximate values. It can be necessary to adjust this data to the individual machining operation.

FTA – Parametri di taglio per inserto SN.. 1205...

ISO	Materiale	Durezza Brinnell HB	Velocità di taglio V _c [m/min]				
			AP2130	AM5740	AK2115	AN1015	AP5230
P	Acciai non legati	< 0,15% C / bonificato	125	210-350			250-360
		0,15-0,45% C / bonificato	150-250	170-320			200-320
		> 0,45% C / bonificato	300	150-280			200-300
	Acciai debolmente legati e Ghise acciaiose	ricotto	180	150-250			200-280
		bonificato	250-300	140-210			200-280
		bonificato	350	100-180			200-300
	Acciai fortemente legati	ricotto	200	140-210			
Acciai da costruzione e Ghise acciaiose	bonificato	350	80-170			200-250	
Acciai inossidabili	ferritico, ricotto	200	140-190			200-250	
Ghisa acciaiosa	martensitico, bonificato	325	100-170				
M	Acciai inossidabili	ferritico, martensitico ricotto	200	90-200	110-240		
		austenitico, temprato	180	90-150	85-170		150-250
		Duplex, temprato	230	70-180	80-210		150-250
		martensitico/austenitico, temprato	330	70-140	80-160		
K	Ghisa grigia	perlitica/ferritico	180		230-400		300-400
		perlitica/martensitico	260		180-320		300-400
	Ghisa sferoidale	ferritico	160		200-310		250-300
		perlitica	-				250-300
Ghisa temprata	ferritico	130		170-240		250-300	
	perlitica	230		150-220		250-300	
N	Leghe di Alluminio stampato	non invecchiato	60			< 2000	
		invecchiato	100			< 2000	
	Leghe di Alluminio da fusione	≤ 12% Si, invecchiato	80			600-780	
		≤ 12% Si, invecchiato	90			530-600	
		≤ 12% Si, non invecchiato	130			290-350	
	Rame e Leghe di Rame (Bronzo / Ottone)	Automatici, Pb > 1%	-			460	
		Ottone, Bronzo	-			310	
		Bronzoalluminio	90			200-250	
		Rame e Rame Elettrolitico	100			200-300	
	Materiali non metallici	Duroplastiche	100				
Plastiche rinforzate		-					
Gomme dure		-					
S	Leghe resistenti al calore	Base-Fe, ricotto	200	60-75			
		Base-Fe, invecchiato	280	60-65			
		Base Ni o Co, ricotto	250	60-70			
		Base Ni o Co 30-58 HRC, da fusione	-	40-60			
		Base Ni o Co 1500-2200 Nmm ² , invecchiato	-				
Leghe di Titanio, Leghe Alpha+Beta	Titanio puro	Rm 440	60-75				
	invecchiato	Rm 1050	45-60				
H	Acciaio Temprato	temprato e rinvenuto	55 HRC				
		temprato e rinvenuto	60 HRC				
	Getti Temprati	da fusione	400				
	Ghisa Temprata	temprato e rinvenuto	55 HRC				

Dati indicativi. Può essere necessario adattarli alle singole applicazioni.

Einsatzempfehlungen für wirtschaftliches Fräsen

Application recommendation for economical milling

Inserto – Parametri di taglio indicativi

ISO	Werkstoff / Material / Materiale	Mittlere Bearbeitung Medium machining Media asportazione			Schrupp-Bearbeitung Rough machining Sgrossatura		
		v_c [m/min]	f_z [mm]	a_p [mm]	v_c [m/min]	f_z [mm]	a_p [mm]
P	Stahl/Steel/Acciaio	150–350	0,1–0,25	1–3	60–150	0,1–0,4	3–5
M	Rostfreier Stahl/Stainless steel/Acciaio inossidabile	130–240	0,1–0,25	1–3	60–150	0,1–0,4	3–5
K	Guss/Cast iron/Ghisa	150–400	0,1–0,25	1–3	150–350	0,1–0,4	3–5
N	NE-Metalle/Non ferrous materials/Materiali non ferrosi	< 2000	0,1–0,15	1–3	< 2000	0,1–0,2	3–5
S	Hochwarmfest/High temperature resistant alloys/Leghe resistenti al calore	25–75	0,1–0,25	1–3	25–75	0,1–0,25	3–5

Die Tabellenwerte sind Richtwerte. Es kann notwendig sein, die Werte den jeweiligen Bearbeitungsumständen anzupassen.
The data given is only approximate values. It can be necessary to adjust this data to the individual machining operation.
Dati indicativi. Può essere necessario adattarli alle singole applicazioni.



ISO	Hartmetall beschichtet Carbide coated Metallo duro rivestito	Hartmetall unbeschichtet Carbide uncoated Metallo duro non rivestito	Schneidstoff Cutting material Materiale da taglio	Anwendung Application Parametri
P Stahl, Stahlguss, langspanender Temperguss Steel, cast steel, long chipping malleable iron Acciaio, acciaio colato, ghisa temprata a truciolo lungo	10		Zähigkeit Toughness Tenacità Verschleißbeständigkeit Resistenza all'usura	Vorschub Feed rate Avanzamento Schnittgeschwindigkeit Cutting speed Velocità di taglio
	20			
	30			
	40			
M Rostfreier Stahl, Stahlguss, Manganstahl, Automatenstahl Stainless steel, cast steel, manganese steel, free cutting steel Acciaio inossidabile, acciaio colato, acciaio al manganese, ghisa legata, ghisa temprata, acciaio automatico, leghe refrattarie	10		Zähigkeit Toughness Tenacità Verschleißbeständigkeit Resistenza all'usura	Vorschub Feed rate Avanzamento Schnittgeschwindigkeit Cutting speed Velocità di taglio
	20			
	30			
	40			
K Grauguss, Kokillenhartguss, kurzspanender Temperguss Grey cast iron, chilled hard cast iron, short chipping malleable iron Ghisa grigia, ghisa fusa in conchiglia, ghisa temprata a truciolo corto, acciaio temprato, metalli non ferrosi, plastica, legno	10		Zähigkeit Toughness Tenacità Verschleißbeständigkeit Resistenza all'usura	Vorschub Feed rate Avanzamento Schnittgeschwindigkeit Cutting speed Velocità di taglio
	20			
	30			
	40			
N Aluminium und Al-Legierungen, nichtmetallische Werkstoffe Aluminium and Al-alloys, non ferrous materials Alluminio e leghe di alluminio, materiali non metallici	10		Zähigkeit Toughness Tenacità Verschleißbeständigkeit Resistenza all'usura	Vorschub Feed rate Avanzamento Schnittgeschwindigkeit Cutting speed Velocità di taglio
	20			
	30			
	40			
S Warmfeste Legierungen, Titanlegierungen High temperature resistant alloys, Titanium alloys Leghe refrattarie, leghe di titanio	10		Zähigkeit Toughness Tenacità Verschleißbeständigkeit Resistenza all'usura	Vorschub Feed rate Avanzamento Schnittgeschwindigkeit Cutting speed Velocità di taglio
	20			
	30			
	40			
H Gehärteter Stahl, Hartguss Hardened Steel, hard cast iron Acciaio temprato, ghisa temprata	10		Zähigkeit Toughness Tenacità Verschleißbeständigkeit Resistenza all'usura	Vorschub Feed rate Avanzamento Schnittgeschwindigkeit Cutting speed Velocità di taglio
	20			
	30			
	40			

Hauptanwendungsbereich / Main application area / Applicazione principale

Nebenanwendungsbereich / Secondary application area / Applicazione secondaria

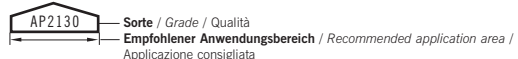

Einsatz-Beispiel der Breitschlichtplatte SNGX 1205ZZ in Sorte AP5230

Application example for wiper insert SNGX 1205ZZ in Grade AP5230

Esempio di utilizzo Inserto raschiante SNGX 1205ZZ in qualità AP5230

Wendeschneidplatte	SNGX 1205ZZ
Indexable insert	SNGX 1205ZZ
Inserti	SNGX 1205ZZ
Werkstoff	42CrMoV4
Material	42CrMoV4
Materiale	42CrMoV4
Festigkeit	1100 N/mm²
Hardness	1100 N/mm ²
Resistenza materiale	1100 N/mm ²
Einsatzbedingungen	trocken
Conditions	dry
Condizioni lavoro	secco
Schnitttiefe (a_p)	0,3 mm
Cutting depth (a _p)	0.3 mm
Profondità di passata (a _p)	0,3 mm
Eingriffsbreite (a_e)	60 %
Cutting width (a _e)	60 %
Largezza contatto (a _e)	60 %
Vorschub pro Zahn (f_z)	1,0 mm
Feed per tooth (f _z)	1.0 mm
Avanzamento a tagliente (f _z)	1,0 mm

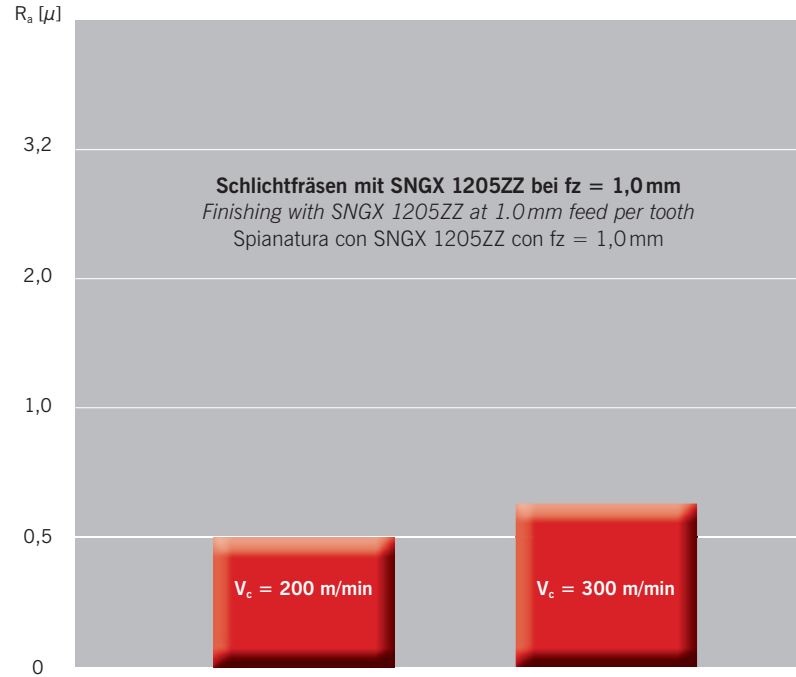

Als Einzahnfräser bestückt mit Wendeschneidplatte SNGX 1205ZZ können Oberflächenqualitäten < R_a 0,5 μ erzielt werden! Geeignet für Spantiefen bis 1 mm.

As single edged cutter with indexable insert SNGX 1205ZZ, surface quality of < R_a 0.5 micron is obtainable. Suitable for depth of cut up to 1 mm.

Con l'utilizzo di un inserto raschiante SNGX 1205ZZ è possibile ottenere finiture superficiali < R_a 0,5 μ Solo per profondità di passata fino a 1 mm.

ARNO®-Frässystem Duo-Mill

- Systemvorstellung
- Bezeichnungssystem
- Werkzeugauswahl
- Trägerwerkzeuge
- Wendeschneidplatten
 - Geometriebeschreibung
 - Sortenbeschreibung
- Werkzeugaufnahmen
- Ersatzteile
- Schnittwerte
- Anwendungshinweise

ARNO®-Duo-Mill milling system

- *System introduction*
- *Designation system*
- *Tool shank options*
- *Holders*
- *Indexable inserts*
 - *Geometry description*
 - *Grade description*
- *Adaptors*
- *Spare parts*
- *Cutting data*
- *Application reference*

ARNO®-Sistema di fresatura Duo-Mill

- Caratteristiche del sistema **46 – 47**
- Sistema di numerazione **48**
- Tipologie di attacco utensile **49**
- Corpi fresa **50 – 55**
- Inserti **56 – 63**
 - Descrizione delle Geometrie **56 – 57**
 - Descrizione delle Qualità **58 – 59**
- Attacchi **64**
- Ricambi **65**
- Parametri di taglio **66 – 79**
- Suggerimenti tecnici **80 – 85**



Eckfräsen und HFC-Fräsen mit nur einem Werkzeug

Square shoulder and high feed (HFC) milling with just one tool

Spallamento retto e fresatura ad alto avanzamento con un solo corpo fresa

2

Duo-Mill ist ein Fräskonzept, mit dem es gelungen ist, 2 geometrisch verschiedene Wendeschneidplatten in einem Plattensitz zu spannen.

Duo-Mill is a milling concept where we successfully can locate 2 geometrically different indexable inserts into the same insert pocket.
Duo-Mill è un innovativo concetto di fresatura che permette di alloggiare due inserti geometricamente diversi in un'unica sede.

Dies ermöglicht verschiedene Fräsbearbeitungen mit nur einem Trägerwerkzeug durch zwei unterschiedliche Anstellwinkel.

By changing the insert we offer different milling operations with just one cutter body.

La sola sostituzione dell'inserto permette di ottenere due operazioni di fresatura differenti utilizzando il medesimo corpo fresa.

1 Grundhalter für 2 verschiedene Bearbeitungsmöglichkeiten durch einfachen Austausch der Wendeschneidplatte.

1 holder for 2 different applications by a simple change of indexable insert.

1 corpo utensile per 2 applicazioni: basta cambiare l'inserto.

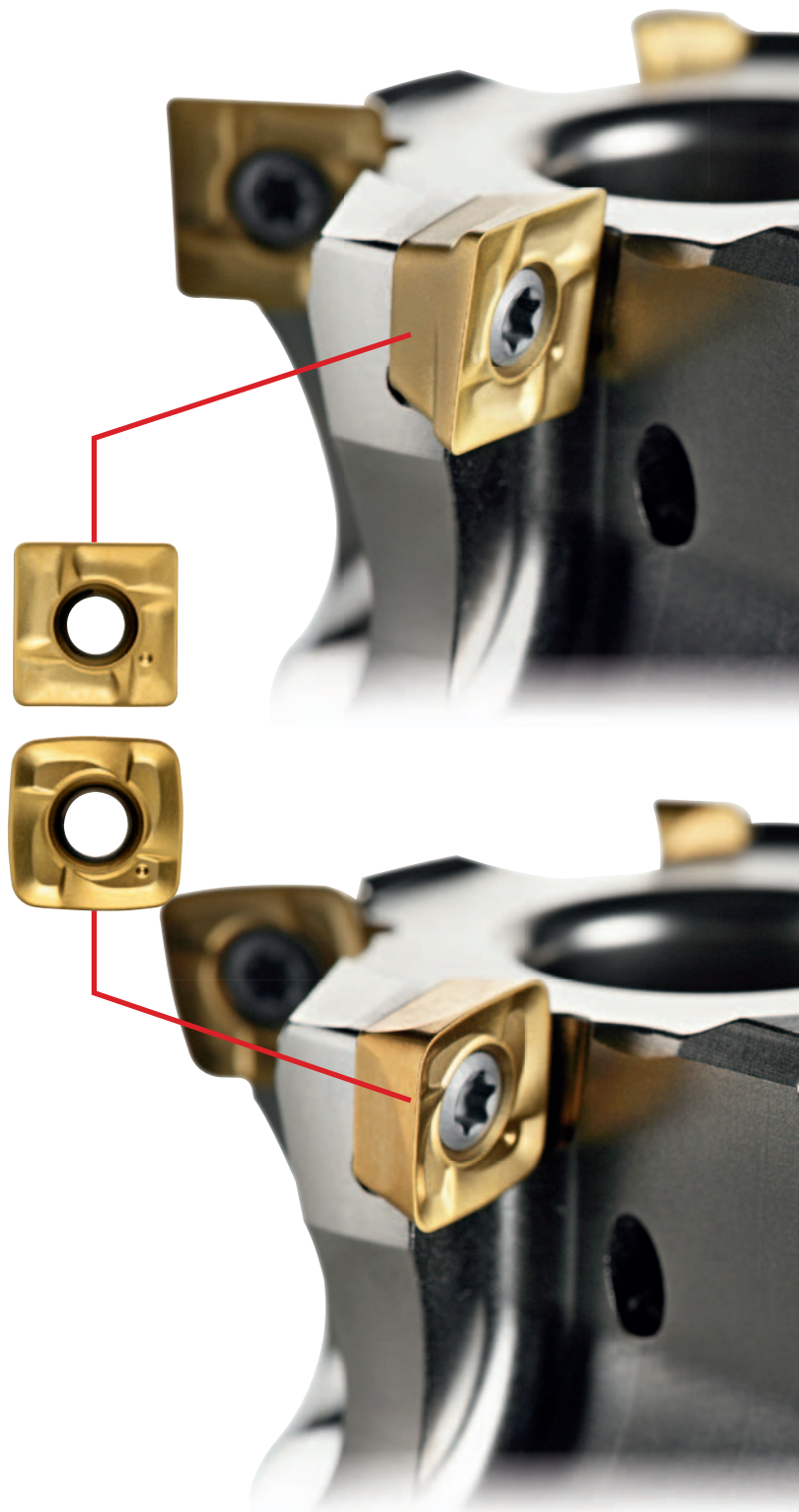

Fakten

- Eckfräsen und HFC-Fräsen mit nur einem Trägerwerkzeug.
 - ▶ **Maximale Einsparung von Werkzeugträgerkosten.**
- 2 verschiedene Wendeschneidplattengrößen auf gleichem Trägerwerkzeug montierbar.
 - ▶ **Hohe Flexibilität für viele Bearbeitungsaufgaben.**
- Schafffräser und Einschraubfräser von 25 mm – 42 mm Durchmesser und Aufsteckfräser von 40 mm – 160 mm Durchmesser.
 - ▶ **Durchgängiges Werkzeugprogramm für viele Bearbeitungsaufgaben.**
- Präzisionsgefertigte und geschliffene Wendeschneidplatten mit speziellen Geometrien.
 - ▶ **Kostengünstige und optimale Lösung für sichere Fräsbearbeitung.**
- 4 effektive Schneidkanten mit 90° beim Eck- und HFC-Fräsen.
 - ▶ **Höchste Effektivität.**

Features

- Square shoulder and HFC-milling with just one tool.
 - ▶ **Maximum savings on tool costs.**
- 2 different indexable inserts for the same tool.
 - ▶ **Flexibility for more applications.**
- Weldon shank and screw shank tools from diameter 25 mm – 42 mm and shell mill cutters from 40 mm – 160 mm diameter.
 - ▶ **Complete range for more applications.**
- Precision finished and ground indexable inserts with dedicated geometries.
 - ▶ **Cost efficient and optimum solutions for secure milling operations.**
- 4 effective cutting edges.
 - ▶ **Maximum efficiency.**

Caratteristiche

- Spallamento retto ed alto avanzamento con un solo utensile.
 - ▶ **Massima riduzione dei costi.**
- 2 diversi inserti per lo stesso corpo fresa.
 - ▶ **Flessibilità per più applicazioni..**
- Gamma corpi fresa con attacchi Weldon e con attacco filettato da 25 mm – 42 mm e dimensioni manicotti da 40 mm – 160 mm di diametro.
 - ▶ **Gamma completa per più applicazioni**
- Inserti precisi, rettificati e lappati con geometrie specifiche.
 - ▶ **Soluzioni ottimali per operazioni di fresatura.**
- Inserti a 4 taglienti effettivi. Fresatura a Spallamento Retto e HFC-Fresatura ad alto avanzamento
 - ▶ **Massima efficienza.**

Trägerwerkzeuge / Holders / Corpi fresa



2

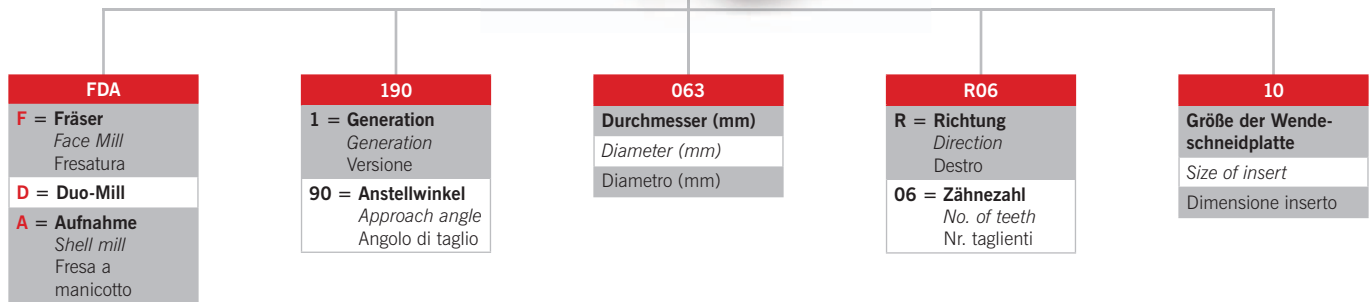

Wendeschneidplatten / Indexable Inserts / Inserti

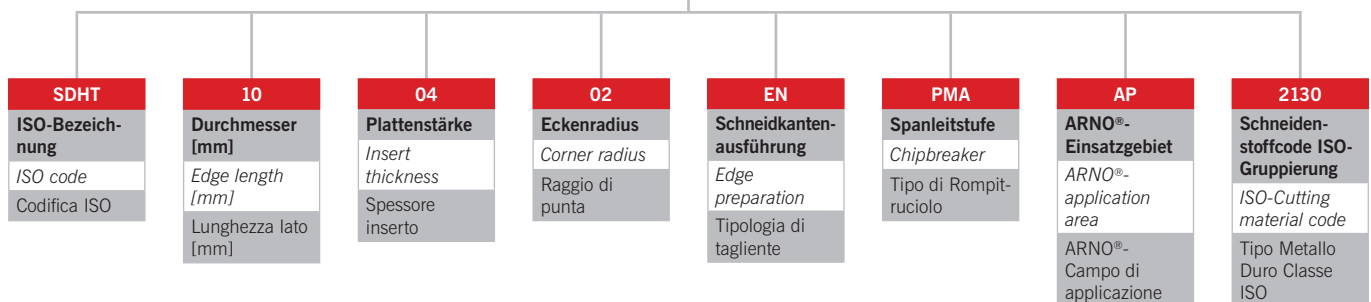



2

Eckfräsen / *Square shoulder* / *Fresatura a Spallamento Retto*

Aufsteckfräser / *Shell mill cutters* / *Fresa a manicotto*

Seite / Page / Pagina **50 – 51**

Schaftfräser / *Cylindrical shank* / *Codolo cilindrico*

Seite / Page / Pagina **52**

Einschraubfräser / *Screw shank cutters* / *Fresa con attacco filettato*

Seite / Page / Pagina **52**

HFC-Fräsen / *HFC-milling* / *HFC-Fresatura ad alto avanzamento*

Aufsteckfräser / *Shell mill cutters* / *Fresa a manicotto*

Seite / Page / Pagina **53 – 54**

Schaftfräser / *Cylindrical shank* / *Codolo cilindrico*

Seite / Page / Pagina **55**

Einschraubfräser / *Screw shank cutters* / *Fresa con attacco filettato*

Seite / Page / Pagina **55**



Eckfräsen

Square shoulder / *Fresatura a Spallamento Retto*

Wendescheidplatten / *Indexable inserts* / *Inserti*

Seite / Page / Pagina **60 – 61**



HFC-Fräsen

HFC-milling / *HFC-Fresatura ad alto avanzamento*

Wendescheidplatten / *Indexable inserts* / *Inserti*

Seite / Page / Pagina **62 – 63**

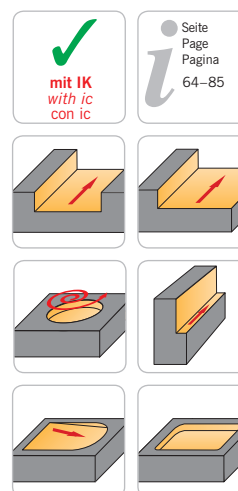
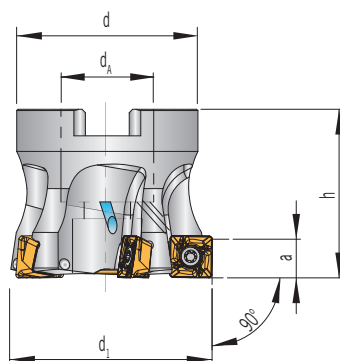

Eckfräser / Square shoulder cutter / Frese per spallamenti – Duo-Mill -10

Bezeichnung Designation Articolo	d ₁	d _A	h	d	a	z	Wendeschneidplatte Indexable insert Inserto
FDA-190.040.R04-10 *	40	16	40	35	9	4	SD.. 10...
FDA-190.040.R06-10 *	40	16	40	35	9	6	SD.. 10...
FDA-190.050.R05-10	50	22	40	43	9	5	SD.. 10...
FDA-190.050.R06-10	50	22	40	43	9	6	SD.. 10...
FDA-190.050.R07-10	50	22	40	48	9	7	SD.. 10...
FDA-190.052.R04-10	52	22	40	43	9	4	SD.. 10...
FDA-190.052.R06-10	52	22	40	43	9	6	SD.. 10...
FDA-190.063.R06-10	63	22	40	48	9	6	SD.. 10...
FDA-190.063.R08-10	63	22	40	48	9	8	SD.. 10...
FDA-190.066.R04-10	66	22	40	48	9	4	SD.. 10...
FDA-190.066.R06-10	66	22	40	40	9	6	SD.. 10...
FDA-190.080.R08-10	80	27	50	60	9	8	SD.. 10...
FDA-190.100.R10-10	100	32	50	78	9	10	SD.. 10...
FDA-190.125.R12-10	125	40	60	90	9	12	SD.. 10...
FDA-190.160.R14-10**	160	40	60	104	9	14	SD.. 10...

* mit Powerschraube AS 0047 (siehe Seite 65)
 * with powerscrew AS 0047 (see page 65)
 * con vite per manicotto AS 0047 (vedi pag. 65)

** ohne Innenkühlung
 ** without internal coolant
 ** senza adduzione interna

Hinweis: Passende Wendeschneidplatten finden Sie ab Seite 60, Spannmittel auf Seite 64.
 Remark: Indexable inserts you find from page 60, face mill adaptors on page 64.
 Nota: Inserti a fissaggio meccanico da pag. 60, mandrini di fresatura a pag. 64.

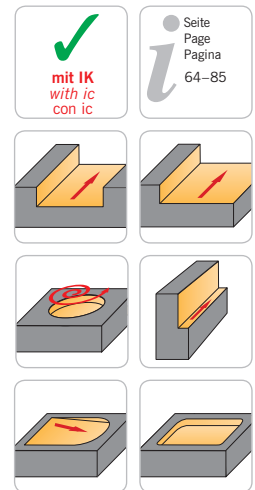
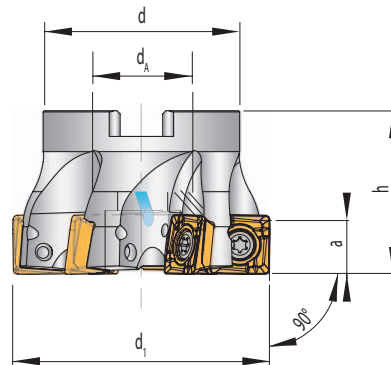

Eckfräser / Square shoulder cutter / Frese per spallamenti – Duo-Mill -15

Bezeichnung Designation Articolo	d ₁	d _A	h	d	a	z	Wendeschneidplatte Indexable insert Inserto
FDA-190.050.R05-15	50	22	40	48	13,5	5	SD.. 15...
FDA-190.052.R03-15	52	22	40	48	13,5	3	SD.. 15...
FDA-190.063.R04-15	63	22	40	48	13,5	4	SD.. 15...
FDA-190.063.R06-15	63	22	40	48	13,5	6	SD.. 15...
FDA-190.066.R04-15	66	22	40	48	13,5	4	SD.. 15...
FDA-190.080.R07-15	80	27	50	67	13,5	7	SD.. 15...
FDA-190.085.R07-15	85	27	50	60	13,5	7	SD.. 15...
FDA-190.100.R09-15	100	32	50	86	13,5	9	SD.. 15...
FDA-190.125.R11-15	125	40	60	104	13,5	11	SD.. 15...
FDA-190.160.R12-15*	160	40	60	104	13,5	12	SD.. 15...

* ohne Innenkühlung
* without internal coolant
* senza adduzione interna

Hinweis: Passende Wendeschneidplatten finden Sie ab Seite 61, Spannmittel auf Seite 64.

Remark: Indexable inserts you find from page 61, face mill adaptors on page 64.

Nota: Inserti a fissaggio meccanico da pag. 61, mandrini di fresatura a pag. 64.

2

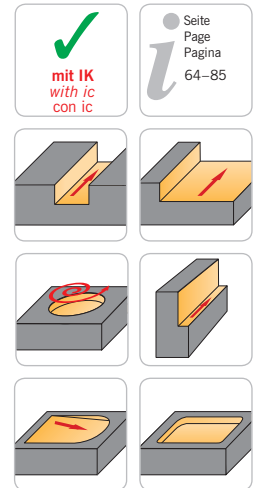
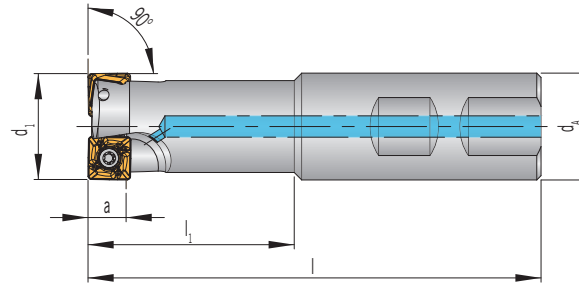

Eckfräser / Square shoulder cutter / Frese per spallamenti – Duo-Mill -10

Bezeichnung Designation Articolo	d ₁	d _A	l	l ₁	a	z	Wendeschneidplatte Indexable insert Inserto
FDC-190.025.R02-10	25	25	106	48	9	2	SD.. 10...
FDC-190.025.R03-10	25	25	106	48	9	3	SD.. 10...
FDC-190.032.R03-10	32	32	124	62	9	3	SD.. 10...
FDC-190.032.R04-10	32	32	124	62	9	4	SD.. 10...

Hinweis: Passende Wendeschneidplatten finden Sie ab Seite 60, Spannmittel auf Seite 64.

Remark: Indexable inserts you find from page 60, face mill adaptors on page 64.

Nota: Inserti a fissaggio meccanico da pag. 60, mandrini di fresatura a pag. 64.

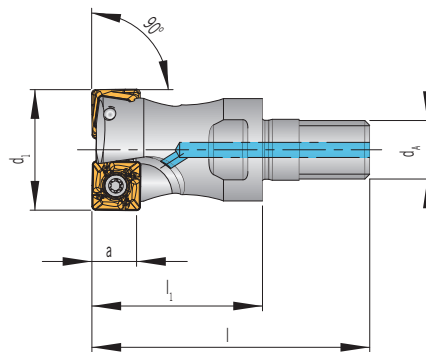
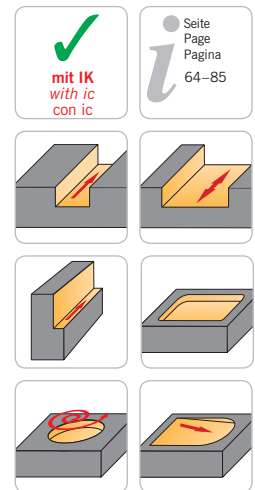

Eckfräser / Square shoulder cutter / Frese per spallamenti – Duo-Mill -10

Bezeichnung Designation Articolo	d ₁	d _A	l	l ₁	a	z	Wendeschneidplatte Indexable insert Inserto
FDG-190.025.R02-10	25	M12	57	35	9	2	SD.. 10...
FDG-190.025.R03-10	25	M12	57	35	9	3	SD.. 10...
FDG-190.032.R03-10	32	M16	58	35	9	3	SD.. 10...
FDG-190.032.R04-10	32	M16	58	35	9	4	SD.. 10...
FDG-190.035.R04-10	35	M16	58	35	9	4	SD.. 10...
FDG-190.040.R04-10	40	M16	58	35	9	4	SD.. 10...
FDG-190.042.R04-10	42	M16	58	35	9	4	SD.. 10...

Hinweis: Passende Wendeschneidplatten finden ab der Seite 60, Spannmittel auf Seite 64.

Remark: Indexable inserts you find from page 60, face mill adaptors on page 64.

Nota: Inserti a fissaggio meccanico da pag. 60, mandrini di fresatura a pag. 64.

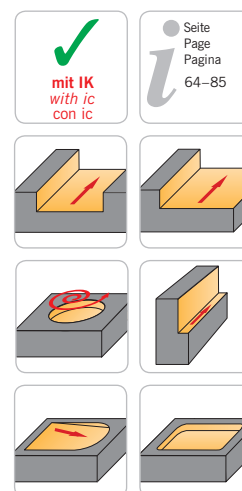
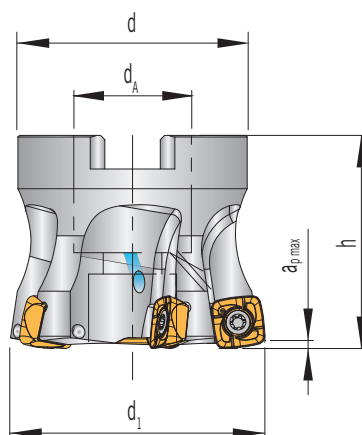

HFC-Fräser / HFC-milling cutter / HFC-Fresatura – Duo-Mill -10

Bezeichnung Designation Articolo	d ₁	d _A	h	d	a _{p max}	z	Wendeschneidplatte Indexable insert Inserto
FDA-190.040.R04-10 *	40	16	40	35	1,5	4	SD.. 10...
FDA-190.040.R06-10 *	40	16	40	35	1,5	6	SD.. 10...
FDA-190.050.R05-10	50	22	40	43	1,5	5	SD.. 10...
FDA-190.050.R06-10	50	22	40	43	1,5	6	SD.. 10...
FDA-190.050.R07-10	50	22	40	48	1,5	7	SD.. 10...
FDA-190.052.R04-10	52	22	40	43	1,5	4	SD.. 10...
FDA-190.052.R06-10	52	22	40	43	1,5	6	SD.. 10...
FDA-190.063.R06-10	63	22	40	48	1,5	6	SD.. 10...
FDA-190.063.R08-10	63	22	40	48	1,5	8	SD.. 10...
FDA-190.066.R04-10	66	22	40	48	1,5	4	SD.. 10...
FDA-190.066.R06-10	66	22	40	40	1,5	6	SD.. 10...
FDA-190.080.R08-10	80	27	50	60	1,5	8	SD.. 10...
FDA-190.100.R10-10	100	32	50	78	1,5	10	SD.. 10...
FDA-190.125.R12-10	125	40	60	90	1,5	12	SD.. 10...
FDA-190.160.R14-10**	160	40	60	104	1,5	14	SD.. 10...

* mit Powerschraube AS 0047 (siehe Seite 65)

* with powerscrew AS 0047 (see page 65)

* con vite per manicotto AS 0047 (vedi pag. 65)

** ohne Innenkühlung

** without internal coolant

** senza adduzione interna

Hinweis: Passende Wendeschneidplatten finden Sie ab Seite 62, Spannmittel auf Seite 64.

Remark: Indexable inserts you find from page 62, face mill adaptors on page 64.

Nota: Inserti a fissaggio meccanico da pag. 62, mandrini di fresatura a pag. 64.

2

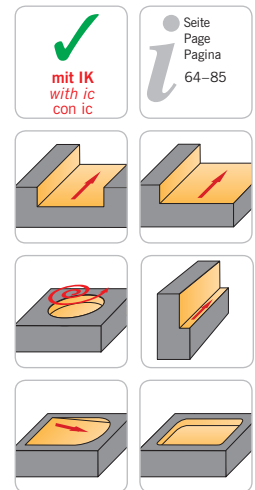
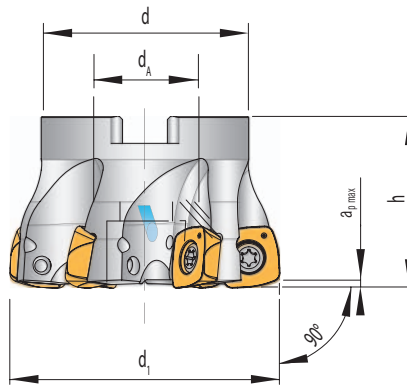

HFC-Fräser / HFC-milling cutter / HFC-Fresatura – Duo-Mill -15

Bezeichnung Designation Articolo	d ₁	d _A	h	d	a _{p max}	z	Wendeschneidplatte Indexable insert Inserto
FDA-190.050.R05-15	50	22	40	48	2,5	5	SD.. 15...
FDA-190.052.R03-15	52	22	40	48	2,5	3	SD.. 15...
FDA-190.063.R04-15	63	22	40	48	2,5	4	SD.. 15...
FDA-190.063.R06-15	63	22	40	48	2,5	6	SD.. 15...
FDA-190.066.R04-15	66	22	40	48	2,5	4	SD.. 15...
FDA-190.080.R07-15	80	27	50	67	2,5	7	SD.. 15...
FDA-190.085.R07-15	85	27	50	60	2,5	7	SD.. 15...
FDA-190.100.R09-15	100	32	50	86	2,5	9	SD.. 15...
FDA-190.125.R11-15	125	40	60	104	2,5	11	SD.. 15...
FDA-190.160.R12-15**	160	40	60	104	2,5	12	SD.. 15...

* ohne Innenkühlung
* without internal coolant
* senza adduzione interna

Hinweis: Passende Wendeschneidplatten finden Sie ab Seite 63, Spannmittel auf Seite 64.

Remark: Indexable inserts you find from page 63, face mill adaptors on page 64.

Nota: Inserti a fissaggio meccanico da pag. 63, mandrini di fresatura a pag. 64.

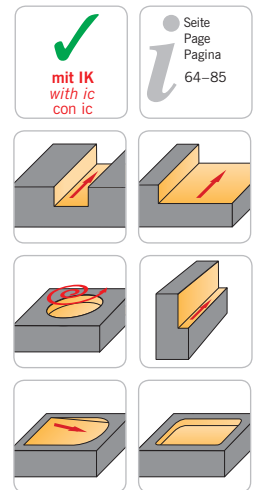
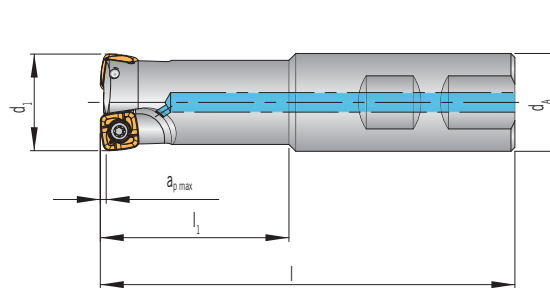

HFC-Fräser / HFC-milling cutter / HFC-Fresatura – Duo-Mill -10

Bezeichnung Designation Articolo	d ₁	d _A	l	l ₁	a _{p max}	z	Wendeschneidplatte Indexable insert Inserto
FDC-190.025.R02-10	25	25	106	47	1,5	2	SD.. 10...
FDC-190.025.R03-10	25	25	106	47	1,5	3	SD.. 10...
FDC-190.032.R03-10	32	32	124	61	1,5	3	SD.. 10...
FDC-190.032.R04-10	32	32	124	61	1,5	4	SD.. 10...

Hinweis: Passende Wendeschneidplatten finden Sie ab Seite 62, Spannmittel auf Seite 64.

Remark: Indexable inserts you find from page 62, face mill adaptors on page 64.

Nota: Inserti a fissaggio meccanico da pag. 62, mandrini di fresatura a pag. 64.

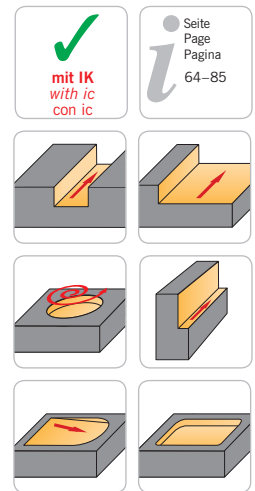
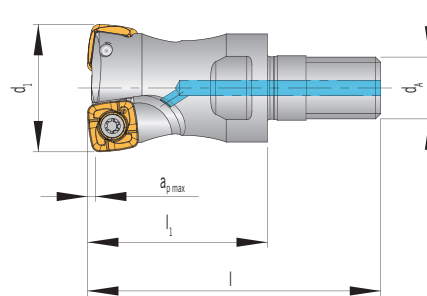

HFC-Fräser / HFC-milling cutter / HFC-Fresatura – Duo-Mill -10

Bezeichnung Designation Articolo	d ₁	d _A	l	l ₁	a _{p max}	z	Wendeschneidplatte Indexable insert Inserto
FDG-190.025.R02-10	25	M12	57	35	1,5	2	SD.. 10...
FDG-190.025.R03-10	25	M12	57	35	1,5	3	SD.. 10...
FDG-190.032.R03-10	32	M16	58	35	1,5	3	SD.. 10...
FDG-190.032.R04-10	32	M16	58	35	1,5	4	SD.. 10...
FDG-190.035.R04-10	35	M16	58	35	1,5	4	SD.. 10...
FDG-190.040.R04-10	40	M16	58	35	1,5	4	SD.. 10...
FDG-190.042.R04-10	42	M16	58	35	1,5	4	SD.. 10...

Hinweis: Passende Wendeschneidplatten finden Sie ab Seite 62, Spannmittel auf Seite 64.

Remark: Indexable inserts you find from page 62, face mill adaptors on page 64.

Nota: Inserti a fissaggio meccanico da pag. 62, mandrini di fresatura a pag. 64.

2

- PMA

Für die Zerspanung von Aluminium und NE-Metallen.



- PMA

For machining aluminium, aluminium alloys and non-ferrous materials.

Schlicht- bis Schrupperzspanung

Finishing to roughing
Finitura e sgrassatura

einseitig
single sided
singolo lato



- PMA

Per la lavorazione di alluminio e materiali non ferrosi.

- PMG

Geometrie für die Zerspanung von Gusswerkstoffen.



- PMG

Geometry for machining cast materials.

Mittlere bis grobe Zerspanung

Medium to rough cutting
Sgrassatura da media a pesante

einseitig
single sided
singolo lato



- PMG

Geometria per la lavorazione di ghisa.

- PMR

Zur Bearbeitung rostfreier Stähle.



- PMR

For machining stainless steels.

Mittlere bis grobe Zerspanung

Medium to rough cutting
Sgrassatura da media a pesante

einseitig
single sided
singolo lato



- PMR

Per la lavorazione di acciaio inox.

- PMS

Geometrie für die Stahlbearbeitung.



- PMS

Geometry for machining steel.

Mittlere bis grobe Zerspanung

Medium to rough cutting
Sgrassatura da media a pesante

einseitig
single sided
singolo lato



- PMS

Geometria per la lavorazione di acciai.

Geometry description – HFC-milling

Descrizione delle Geometrie – HFC-Fresatura ad alto avanzamento

- PSR

Zur Bearbeitung rostfreier Stähle.



- PSR

For machining stainless steels.

Mittlere bis grobe Zerspanung
 Medium to rough cutting
 Sgrossatura da media a pesante

einseitig
 single sided
 singolo lato



- PSR

Per la lavorazione di acciaio inox.

- PSS

Geometrie für die Stahlbearbeitung.



- PSS

Geometry for machining steel.

Schlicht- und mittlere Zerspanung
 Finishing and medium machining
 Finitura e medie asportazioni

einseitig
 single sided
 singolo lato



- PSS

Geometria per la lavorazione di acciai.



Hartmetall beschichtet / Carbide grade coated / Metallo duro rivestito**AK5315**

PVD-beschichtete Hartmetallsorte mit einer TiAlN-Beschichtung. Der Hauptanwendungsbereich dieser Sorte ist die Fräsbearbeitung von Gusswerkstoffen (GG und GGG).

PVD coated (TiAlN) carbide insert. The main application area for this grade is cast iron (GG and GGG).

Inserto con rivestimento PVD (TiAlN). Qualità specifica per la fresatura di Ghise grigie e Sferoidali (GG e GGG).

AM5740

PVD-beschichtete Hartmetallsorte mit einer AlTiN-Mehrlagenbeschichtung. Hauptanwendung rostfreier Stahl. Allroundsorte für die moderne Bearbeitung, die eine gute Ausgewogenheit in Bezug auf die Bearbeitungssicherheit und Produktivität bietet.

PVD coated (AlTiN multilayer) carbide insert. Main application stainless steel. For milling stainless steel at medium to high cutting speeds, also suitable for milling high temperature alloys and titanium alloys.

Inserto con rivestimento multistrato (AlTiN) PVD. Prima scelta per lavorazione di acciai inossidabili. Per la fresatura di acciaio inossidabile a velocità di taglio da medie ad alte, adatto anche per la fresatura di leghe resistenti al calore o leghe di titanio.

AP5215

PVD-Mehrlagenbeschichtung Hauptanwendung NE-Metalle. Universelle Sorte zur Schlichtbearbeitung von Gusswerkstoffen, Stahl und rostfreien Stählen. Auch sehr gut geeignet für die Feinbearbeitung von exotischen Werkstoffen.

PVD-multilayer coating Main application non ferrous materials. Light machining of exotic materials. Finishing of cast materials, steel and stainless steel.

Rivestimento PVD-multistrato Utilizzo principale per lavorazione di materiali non metallici. Ottima per la superfinitura di ghisa, acciai e acciai inossidabili. Qualità utilizzabile anche per finitura di materiali esotici.

AP5330

PVD-beschichtete Hartmetallsorte mit einer TiAlN-Beschichtung. Allroundsorte für die moderne Bearbeitung, die eine gute Ausgewogenheit in Bezug auf die Bearbeitungssicherheit und Produktivität bietet.

PVD coated (TiAlN) carbide insert. Universal grade for the modern production where machine reliability and high productivity is essential. Main application area is steel.

Inserto con rivestimento multistrato (TiAlN) PVD. Grado universale per la moderna produzione dove sono essenziali affidabilità e produttività. Qualità specifica per acciaio.

AP5430

PVD-beschichtete Hartmetallsorte mit einer TiAlN-Beschichtung + TiN-Zusatzbeschichtung. Allroundsorte für die Fräsbearbeitung sämtlicher Stahlwerkstoffe. Substrat mit guter Zähigkeitreserve in Kombination mit hoher Verschleißfestigkeit.

PVD coated (TiAlN/TiN) carbide insert. General purpose grade for all steel machining, tough yet wear resistant. TiN coating for easier wear recognition.

Inserto con rivestimento multistrato (TiAlN/TiN) PVD. Grado per acciaio, tenace e allo stesso tempo resistente all'usura. Rivestimento Tin per un miglior riconoscimento dell'usura.

AP5830+

PVD-beschichtete Hartmetallsorte. Besonders geeignet zum Nassfräsen von Stählen, rostfreien Werkstoffen und Gusswerkstoffen. Eine universell einsetzbare Sorte gegen Kammrissebildung.

PVD-carbide grade. Especially suitable for wet milling of steel, stainless steel and cast materials. A universal grade, very resistant to thermal cracking.

Metallo duro rivestito PVD. Qualità studiata appositamente per lavorazioni con refrigerante di acciaio, acciaio inossidabile e acciai stampati o da fusione. Un grado universale, molto resistente a shock termici.

Hartmetall unbeschichtet / Carbide grade uncoated / Metallo duro non rivestito**AN1015**

Unbeschichtete Hartmetallsorte. Sorte zur Bearbeitung von Aluminium und NE-Metallen. Zur Reduzierung der Aufbauschneidenbildung ist die Spanfläche hochglanzpoliert.

Uncoated carbide inserts. For milling aluminium and non-ferrous materials. Insert is polished to reduce build up edge.

Metallo duro non rivestito. Qualità di metallo duro specifica per la lavorazione di materiali non ferrosi. Ridotte forze di taglio grazie ad un tagliente affilato e ad una superficie dell'inserto lappata.

2

Hartmetall beschichtet / Carbide grade coated / Metallo duro rivestito**AM5740**

PVD-beschichtete Hartmetallsorte mit einer AlTiN-Mehrlagenbeschichtung.
Zum Fräsen von rostfreien Stählen bei mittleren und hohen Schnittgeschwindigkeiten. Nebenwendung zum Fräsen warmfester Legierungen und Titanlegierungen.

PVD coated (AlTiN multilayer) carbide insert. For milling stainless steel at medium to high cutting speeds, also suitable for milling high temperature alloys and titanium alloys.

Inserto con rivestimento multistrato (AlTiN) PVD.
Per la fresatura di acciaio inossidabile a velocità di taglio da medie ad alte, adatto anche per la fresatura di leghe resistenti al calore o leghe di titanio.

AP5325

PVD-beschichtete Hartmetallsorte mit einer TiAlN-Beschichtung.
Zum Fräsen von allgemeinen Stählen für die Schlicht- und Schruppbearbeitung bei mittleren bis hohen Schnittgeschwindigkeiten.

PVD coated (TiAlN) carbide insert. For general milling of steel. Roughing and finishing at medium to high cutting speeds.

Inserto con rivestimento multistrato (TiAlN) PVD.
Qualità specifica per acciaio. Sgrossatura e finitura a velocità medie ed elevate.

AP5335

PVD-beschichtete Hartmetallsorte für die Zerspanung von Stahl mit hoher Zähigkeit im Substrat.
Geringe Neigung zu Schneidkantenausbrüchen.

Very tough PVD coated grade for machining steel. High resistance to cutting edge breakage.

Grado molto tenace con rivestimento PVD.
Per la lavorazione di acciaio. Alta resistenza contro le scheggiature.

AP5340

PVD-beschichtete Hartmetallsorte mit einer TiAlN-Beschichtung.
Erste Wahl für instabile Bedingungen. Kann auch als Unterstützungssorte bei zähigkeitsfordernden Operationen eingesetzt werden.

PVD coated (TiAlN) carbide insert. Preferred choice for unstable conditions. Can also be used where extreme toughness is required.

Inserto con rivestimento multistrato (TiAlN) PVD.
Qualità per condizioni instabili di lavorazione. Può essere usato anche dove è necessaria massima tenacità.

AP5440

PVD-beschichtete Hartmetallsorte mit einer TiAlN-Beschichtung + TiN-Zusatzbeschichtung.
Erste Wahl bei instabilen Bedingungen, längeren Auskraglängen und niedrigen bis mittleren Schnittgeschwindigkeiten.

PVD coated (TiAlN/TiN) carbide insert. Preferred choice for unstable conditions, long overhang and medium to low cutting speeds.

Inserto con rivestimento multistrato (TiAlN/TiN) PVD.
Da preferire per condizioni di lavoro instabili e velocità medio-basse.

AP5830+

PVD-beschichtete Hartmetallsorte.
Besonders geeignet zum Nassfräsen von Stählen, rostfreien Werkstoffen und Gusswerkstoffen. Eine universell einsetzbare Sorte gegen Kammrisbildung.

PVD coated carbide grade. Especially suitable for wet milling of steel, stainless steel and cast materials. A universal grade, very resistant to thermal cracking.

Metallo duro rivestito PVD.
Qualità studiata appositamente per lavorazioni con refrigerante di acciaio, acciaio inossidabile e acciai stampati o da fusione. Un grado universale, molto resistente a shock termici.

Duo-Mill -10

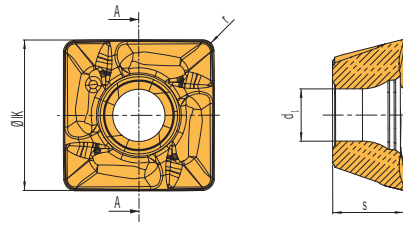

2

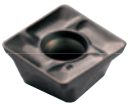
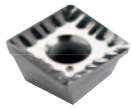

Bezeichnung Designation Articolo	IK	s	d ₁	r	beschichtet coated rivestito						unbeschichtet uncoated non rivestito	
					AK5315	AM5740	AP5215	AP5330	AP5430	AP5830+	AN1015	
SDHT 100402FN-PMA	10,1	4,76	3,5	0,2			●					●
SDHT 100404FN-PMA	10,1	4,76	3,5	0,4								●
SDHT 100408FN-PMA	10,1	4,76	3,5	0,8			●					●
SDMT 100408EN-PMG	10,1	4,76	3,5	0,8	●							
SDMT 100408EN-PMR	10,1	4,76	3,5	0,8		●						
SDMT 100408EN-PMS	10,1	4,76	3,5	0,8				●	●	●		

- Hauptanwendung
Main application
Applicazione principale
- Nebenanwendung
Secondary application
Applicazione secondaria

P			○	●	●	●
M		●	○			●
K	●		○			●
N			●			●
S		●	○			
H						

Duo-Mill -15

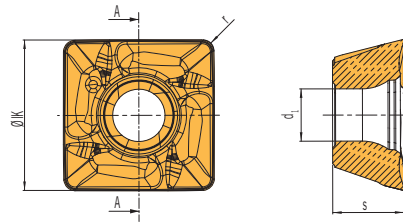

Bezeichnung Designation Articolo	IK	s	d ₁	r	beschichtet coated rivestito						unbeschichtet uncoated non rivestito	
					AK5315	AM5740	AP5215	AP5330	AP5430	AP5830+	AN1015	
SDHT 155012FN-PMA	14,7	5	5,5	1,2								●
SDMT 155012EN-PMG	14,7	5	5,5	1,2	●							
SDMT 155012EN-PMR	14,7	5	5,5	1,2		●						
SDMT 155012EN-PMS	14,7	5	5,5	1,2				●	●	●		

- Hauptanwendung
Main application
Applicazione principale
- Nebenanwendung
Secondary application
Applicazione secondaria

P			○	●	●	●
M		●	○			●
K	●		○			●
N			●			●
S		●	○			
H						

2

Duo-Mill -10

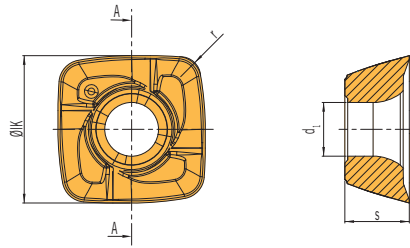

2



Bezeichnung Designation Articolo	IK	s	d ₁	r	AM5740	AP5325	AP5335	AP5340	AP5440	AP5830+
SDMT 100415SN-PSS	9,6	4,20	3,5	1,5		●	●			●
SDMW 100415SN-PSS	9,6	4,20	3,5	1,5				●		
SDMW 100415SN-PSS	9,6	4,20	3,5	1,5					●	
SDMT 100415SN-PSR	9,6	4,20	3,5	1,5	●					

- Hauptanwendung
Main application
Applicazione principale
- Nebenanwendung
Secondary application
Applicazione secondaria

P		●	●	●	●	●	
M	●						●
K			○				●
N							
S	○						
H							

Duo-Mill -15

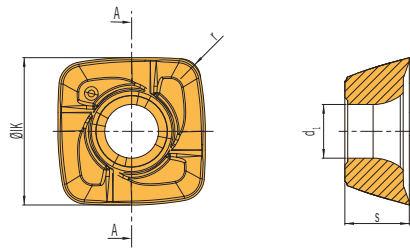

Bezeichnung Designation Articolo	IK	s	d ₁	r	AM5740	AP5325	AP5335	AP5340	AP5440	AP5830+
SDMT 155020SN-PSS	14,2	5	5,5	2		●			●	
SDMW 155020SN-PSS	14,2	5	5,5	2				●		
SDMW 155020SN-PSS	14,2	5	5,5	2						●
SDMT 155020SN-PSR	14,2	5	5,5	2	●					

- Hauptanwendung
Main application
Applicazione principale
- Nebenanwendung
Secondary application
Applicazione secondaria

P		●	●	●	●	●	
M	●						●
K			○				●
N							
S	○						
H							

2

Werkzeugaufnahme SK40 für Duo-Mill Fräser

SK40 face mill adaptors for Duo-Mill cutters / Attacchi SK40 per Frese

Fräser-Ø Cutter-Ø Fresatura-Ø	L	Werkzeugaufnahme Adaptor Attacco SK40 DIN 69871	Werkzeugaufnahme Adaptor Attacco SK40 MAS BT
[mm]	[mm]	Bezeichnung Designation Articolo	Bezeichnung Designation Articolo
40	40	69871AD+B-40-16x35IK-L40	BT40AD+B-16x35IK-L40
50	40	69871AD+B-40-22x43IK-L40	BT40AD+B-22x43IK-L40
63	40	69871AD+B-40-22x48IK-L40	BT40AD+B-22x48IK-L40
80	50	69871AD+B-40-27x60IK-L50	BT40AD+B-27x60IK-L50
100	50	69871AD+B-40-32x78IK-L50	BT40AD+B-32x78IK-L50
125	50	69871AD+B-40-40x90IK-L50	BT40AD+B-40x90IK-L50
160	50	69871AD+B-40-40x104IK-L50	BT40AD+B-40x104IK-L50

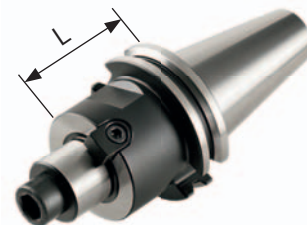

2

Werkzeugaufnahme HSK63 für Duo-Mill Fräser

HSK63 face mill adaptors for Duo-Mill cutters / Attacchi HSK63 per Frese

Fräser-Ø Cutter-Ø Fresatura-Ø	L	Werkzeugaufnahme Adaptor Attacco SK40 DIN 69871
[mm]	[mm]	Bezeichnung Designation Articolo
40	40	HSK-A63-16x35IK-L40
50	40	HSK-A63-22x43IK-L40
63	40	HSK-A63-22x48IK-L40
80	55	HSK-A63-27x60IK-L55
100	60	HSK-A63-32x78IK-L60
125	60	HSK-A63-40x90IK-L60
160	60	HSK-A63-40x104IK-L60



Werkzeugaufnahme SK40 für Duo-Mill Fräser

SK40 face mill adaptors for Duo-Mill cutters / Attacchi SK40 per Frese

Fräser-Ø Cutter-Ø Fresatura-Ø	L	Werkzeugaufnahme Adaptor Attacco
[mm]	[mm]	Bezeichnung Designation Articolo
25	69	69871AD-40-M12-21x50IK-L69
25	119	69871AD-40-M12-21x100IK-L119
32-42	69	69871AD-40-M16-29x50IK-L69
32-42	119	69871AD-40-M16-29x100IK-L119

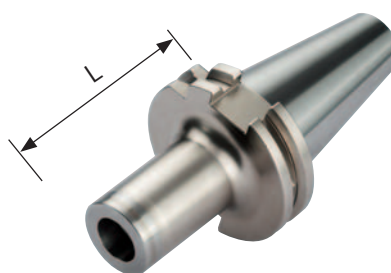

Werkzeugaufnahme HSK63 für Duo-Mill Fräser

HSK63 face mill adaptors for Duo-Mill cutters / Attacchi HSK63 per Frese

Fräser-Ø Cutter-Ø Fresatura-Ø	L	Werkzeugaufnahme Adaptor Attacco
[mm]	[mm]	Bezeichnung Designation Articolo
25	76	HSK-A63-M12-21x50IK-L76
25	126	HSK-A63-M12-21x100IK-L126
32-42	76	HSK-A63-M16-29x50IK-L76
32-42	126	HSK-A63-M16-29x100IK-L126

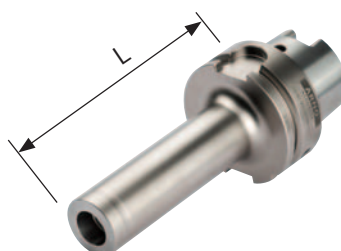

Schrauben und Schraubendreher

Screws and Screwdrivers

Chiavi e Viti

Bezeichnung Designation Articolo	Drehmoment Torque Forza di serraggio	TorxPlus®-Spannschraube TorxPlus®-Screw TorxPlus®-Vite	TorxPlus®-Schlüssel TorxPlus®-Key TorxPlus®-Chiave
Duo-Mill -10	3 Nm	AS 0042	(T5110 IP)
Duo-Mill FDA190-040... -10	-	AS 0047*	Imbus 4 mm
Duo-Mill -15	5 Nm	AS 0046	(T5120 IP)

* Powerschraube L/R M8x29

* Powerscrew L/R M8x29

* Vite a doppio principio L/R M8x29

HINWEIS TROCKENBEARBEITUNG:

Es kann zur erhöhten Wärmeentwicklung des Trägers bzw. der Schrauben führen.

- Bitte rechtzeitig einen Schraubenwechsel durchführen
- Bei erhitztem Werkzeug keinen Plattenwechsel vornehmen, abkühlen lassen, ggf. mit Schwesterwerkzeug arbeiten
- Schraubenwechsel nur mit IP-Schlüssel bzw. Drehmomentschlüssel durchführen

INFO DRY MACHINING:

Can lead to increased temperature to the tool and the screws.

- Please change screws accordingly.
- Please do not replace inserts while the holder is hot. Either leave tool to cool down or work with similar sister tooling.
- Use torx plus and torque screwdriver when replacing insert screws.

NOTA LAVORAZIONE A SECCO:

Si possono riscontrare elevate temperatura sull'inserto, vite e corpo fresa:

- Non sostituire inserti e viti mentre il corpo utensile è caldo. Lasciare raffreddare l'utensile.
- Utilizzare chiave dinamometrica quando si sostituiscono le viti
- prevedere una sostituzione delle viti appropriata



Hinweis: Drehmoment-Schraubendreher siehe Seite 289.

Remark: For torque screwdrivers see page 289.

Nota: Chiavi dinamometriche a pagina 289.

Duo-Mill -10 – Schnittdatenrichtwerte Eckfräsen mit SD..100408...

ISO	Werkstoff	Brinell-Härte HB	Schnittgeschwindigkeit V _c [m/min]						
			AK5315	AM5740	AP5215	AP5330	AP5430	AP5830+	AN1015
P	Unlegierter Stahl und Stahlguss	< 0,15 % C / vergütet				100–220	100–220	100–220	
		0,15–0,45 % C / vergütet	125			100–220	100–220	100–220	
		> 0,45 % C / vergütet	150–250			100–220	100–220	100–220	
	Niedrig legierter Stahl und Stahlguss	gegült	300			80–220	80–220	80–220	
		vergütet	180			80–220	80–220	80–220	
		vergütet	250–300			80–220	80–220	80–220	
Hochlegierter Stahl, hochlegierter Werkzeugstahl und Stahlguss	gegült	350			80–180	80–180	80–180		
	vergütet	200			80–180	80–180	80–180		
Nichtrostender Stahl und Stahlguss	ferritisch, gegült	325			70–180	70–180	70–180		
	martensitisch, vergütet	200			70–180	70–180	70–180		
M	Nichtrostender Stahl	ferritisch, martensitisch gegült	200	60–200					
		austenitisch, abgeschreckt	180	60–200					
		Duplex, abgeschreckt	230	60–200					
		martensitisch/austenitisch, abgeschreckt	330	60–200					
K	Grauguss	perlitisches/ferritisches	180	180–350					
		perlitisches/martensitisches	260	140–280					
	Gusseisen mit Kugelgraphit	ferritisch	160	130–250					
		perlitisches	–	100–200					
Temperguss	ferritisch	130	150–320						
	perlitisches	230	120–250						
N	Aluminium-Knetlegierungen	nicht aushärtbar	60		440–1500			400–1500	
		aushärtbar, ausgehärtet	100		440–1500			400–1500	
	Aluminium-Gusslegierungen	≤ 12 % Si, ausgehärtet	80		440–1500			400–1500	
		≤ 12 % Si, aushärtbar, ausgehärtet	90		330–1200			300–1200	
		≤ 12 % Si, nicht aushärtbar	130		220–1000			200–1000	
	Kupfer und Kupferlegierungen (Bronze / Messing)	Automatenlegierung, Pb > 1%	–		220–600			200–600	
		Messing, Rotguss	–		275–1000			250–1000	
		Aluminiumbronze	90		165–400			150–400	
Kupfer und Elektrolytkupfer		100		330–800			300–800		
Nichtmetallische Werkstoffe	Duroplaste	100		90–1000			80–1000		
	Faserverstärkte Kunststoffe	–		85–500			75–500		
	Hartgummi	–		90–300			80–300		
S	Warmfeste Legierungen	Fe-Basis, gegült	200	20–60					
		Fe-Basis, ausgehärtet	280	20–60					
		Ni- oder Co-Basis, gegült	250	20–60					
		Ni- oder Co-Basis 30-58 HRC, gegossen	–	20–30					
		Ni- oder Co-Basis 1500-2200 Nmm ² , ausgehärtet	–	20–30					
Titanlegierungen, Alpha+Beta-Legierungen	Rein-Titan	Rm 440	40–70						
	ausgehärtet	Rm 1050	20–40						
H	Gehärteter Stahl	gehärtet und angelassen	55 HRC						
		gehärtet und angelassen	60 HRC						
	Hartguss	gegossen	400						
Gehärtetes Gusseisen	gehärtet und angelassen	55 HRC							

Die Tabellenwerte sind Richtwerte. Es kann notwendig sein, die Werte den jeweiligen Bearbeitungsumständen anzupassen.

Duo-Mill -15 – Schnittdatenrichtwerte Eckfräsen mit SD..155012...

ISO	Werkstoff		Brinell-Härte HB	Schnittgeschwindigkeit V _c [m/min]						
				AK5315	AM5740	AP5215	AP5330	AP5430	AP5830+	AN1015
P	Unlegierter Stahl und Stahlguss	< 0,15 % C / vergütet	125				100–220	100–220	100–220	
		0,15–0,45 % C / vergütet	150–250				100–220	100–220	100–220	
		> 0,45 % C / vergütet	300				100–220	100–220	100–220	
	Niedrig legierter Stahl und Stahlguss	gegült	180				80–220	80–220	80–220	
		vergütet	250–300				80–220	80–220	80–220	
		vergütet	350				80–220	80–220	80–220	
	Hochlegierter Stahl, hochlegierter Werkzeugstahl und Stahlguss	gegült	200				80–220	80–220	80–220	
vergütet		350				80–220	80–220	80–220		
Nichtrostender Stahl und Stahlguss	ferritisch, gegült	200				70–180	70–180	70–180		
	martensitisch, vergütet	325				70–180	70–180	70–180		
M	Nichtrostender Stahl	ferritisch, martensitisch gegült	200		60–200					
		austenitisch, abgeschreckt	180		60–200					
		Duplex, abgeschreckt	230		60–200					
		martensitisch/austenitisch, ausgehärtet	330		60–200					
K	Grauguss	perlitisch/ferritisch	180	180–350						
		perlitisch/martensitisch	260	140–280						
	Gusseisen mit Kugelgraphit	ferritisch	160	130–250						
		perlitisch	–	100–200						
Temperguss	ferritisch	130	150–320							
	perlitisch	230	120–250							
N	Aluminium-Knetlegierungen	nicht aushärtbar	60			440–1500			400–1500	
		aushärtbar, ausgehärtet	100			440–1500			400–1500	
	Aluminium-Gusslegierungen	≤ 12 % Si, ausgehärtet	80			440–1500			400–1500	
		≤ 12 % Si, aushärtbar, ausgehärtet	90			330–1200			300–1200	
		≤ 12 % Si, nicht aushärtbar	130			220–1000			200–1000	
	Kupfer und Kupferlegierungen (Bronze / Messing)	Automatenlegierung, Pb > 1%	–			220–600			200–600	
		Messing, Rotguss	–			275–1000			250–1000	
		Aluminiumbronze	90			165–400			150–400	
		Kupfer und Elektrolytkupfer	100			330–800			300–800	
	Nichtmetallische Werkstoffe	Duroplaste	100			90–1000			80–1000	
Faserverstärkte Kunststoffe		–			85–500			75–500		
Hartgummi		–			90–300			80–300		
S	Warmfeste Legierungen	Fe-Basis, gegült	200		20–60					
		Fe-Basis, ausgehärtet	280		20–60					
		Ni- oder Co-Basis, gegült	250		20–60					
		Ni- oder Co-Basis 30-58 HRC, gegossen	–		20–30					
		Ni- oder Co-Basis 1500-2200 Nmm ² , ausgehärtet	–		20–30					
Titanlegierungen, Alpha+Beta-Legierungen	Rein-Titan	Rm 440		40–70						
	ausgehärtet	Rm 1050		20–40						
H	Gehärteter Stahl	gehärtet und angelassen	55 HRC							
		gehärtet und angelassen	60 HRC							
	Hartguss	gegossen	400							
	Gehärtetes Gusseisen	gehärtet und angelassen	55 HRC							

Die Tabellenwerte sind Richtwerte. Es kann notwendig sein, die Werte den jeweiligen Bearbeitungsumständen anzupassen.



Duo-Mill -10 – Schnittdatenrichtwerte HFC-Fräsen mit SD..100415

ISO	Werkstoff		Brinell-Härte HB	Schnittgeschwindigkeit V _c [m/min]					
				AM15740	AP5325	AP5335	AP5340	AP5440	AP5830+
P	Unlegierter Stahl und Stahlguss	< 0,15 % C / vergütet	125		220–300	200–260	200–275	200–275	200–275
		0,15–0,45 % C / vergütet	150–250		220–300	200–260	200–275	200–275	200–275
		> 0,45 % C / vergütet	300		220–300	200–260	200–275	200–275	200–275
	Niedrig legierter Stahl und Stahlguss	gegült	180		220–300	200–260	200–275	200–275	200–275
		vergütet	250–300		220–300	200–260	200–275	200–275	200–275
		vergütet	350		220–300	200–260	200–275	200–275	200–275
	Hochlegierter Stahl, hochlegierter Werkzeugstahl und Stahlguss	gegült	200		160–235	160–220	180–235	180–235	180–235
vergütet		350		160–235	160–220	180–235	180–235	180–235	
Nichtrostender Stahl	ferritisch, gegült	200		160–235	160–220	180–220	180–220	180–220	
Stahlguss	martensitisch, vergütet	325		160–235	160–220	180–220	180–220	180–220	
M	Nichtrostender Stahl	ferritisch, martensitisch gegült	200	120–220					
		austenitisch, abgeschreckt	180	120–220					
		Duplex, abgeschreckt	230	120–220					
		martensitisch/austenitisch, abgeschreckt	330	120–220					
K	Grauguss	perlitisch/ferritisch	180	220–300					
		perlitisch/martensitisch	260	200–280					
	Gusseisen mit Kugelgraphit	ferritisch	160	200–250					
		perlitisch	–	180–235					
Temperguss	ferritisch	130	220–300						
	perlitisch	230	200–250						
N	Aluminium-Knetlegierungen	nicht aushärtbar	60						
		aushärtbar, ausgehärtet	100						
	Aluminium-Gusslegierungen	≤ 12 % Si, ausgehärtet	80						
		≤ 12 % Si, aushärtbar, ausgehärtet	90						
		≤ 12 % Si, nicht aushärtbar	130						
	Kupfer und Kupferlegierungen (Bronze / Messing)	Automatenlegierung, Pb > 1%	–						
		Messing, Rotguss	–						
Aluminiumbronze		90							
Kupfer und Elektrolytkupfer		100							
Nichtmetallische Werkstoffe	Duroplaste	100							
	Faserverstärkte Kunststoffe	–							
	Hartgummi	–							
S	Warmfeste Legierungen	Fe-Basis, gegült	200	60–120					
		Fe-Basis, ausgehärtet	280	60–120					
		Ni- oder Co-Basis, gegült	250	40–100					
		Ni- oder Co-Basis 30–58 HRC, gegossen	–	40–100					
		Ni- oder Co-Basis 1500–2200 Nmm ² , ausgehärtet	–	40–80					
Titanlegierungen, Alpha+Beta-Legierungen	Rein-Titan	Rm 440	40–80						
	ausgehärtet	Rm 1050	40–80						
H	Gehärteter Stahl	gehärtet und angelassen	55 HRC						
		gehärtet und angelassen	60 HRC						
	Hartguss	gegossen	400						
Gehärtetes Gusseisen	gehärtet und angelassen	55 HRC							

Die Tabellenwerte sind Richtwerte. Es kann notwendig sein, die Werte den jeweiligen Bearbeitungsumständen anzupassen.

Duo-Mill -15 – Schnittdatenrichtwerte HFC-Fräsen mit SD..155020

ISO	Werkstoff		Brinell-Härte HB	Schnittgeschwindigkeit V _c [m/min]				
				AM5740	AP5325	AP5340	AP5440	AP5830+
P	Unlegierter Stahl und Stahlguss	< 0,15 % C / vergütet	125		220–300	200–275	200–275	200–275
		0,15–0,45 % C / vergütet	150–250		220–300	200–275	200–275	200–275
		> 0,45 % C / vergütet	300		220–300	200–275	200–275	200–275
	Niedrig legierter Stahl und Stahlguss	geglüht	180		220–300	200–275	200–275	200–275
		vergütet	250–300		220–300	200–275	200–275	200–275
		vergütet	350		220–300	200–275	200–275	200–275
	Hochlegierter Stahl, hochlegierter Werkzeugstahl und Stahlguss	geglüht	200		180–235	180–235	180–235	180–235
vergütet		350		180–235	180–235	180–235	180–235	
Nichtrostender Stahl	ferritisch, geglüht	200		180–235	180–235	180–220	180–220	
Stahlguss	martensitisch, vergütet	325		180–235	180–235	180–220	180–220	
M	Nichtrostender Stahl	ferritisch, martensitisch geglüht	200	120–220				
		austenitisch, abgeschreckt	180	120–220				
		Duplex, abgeschreckt	230	120–220				
		martensitisch/austenitisch, abgeschreckt	330	120–220				
K	Grauguss	perlitisch/ferritisch	180		220–300			
		perlitisch/martensitisch	260		200–280			
	Gusseisen mit Kugelgraphit	ferritisch	160		200–250			
		perlitisch	–		180–235			
Temperguss	ferritisch	130		220–280				
	perlitisch	230		200–250				
N	Aluminium-Knetlegierungen	nicht aushärtbar	60					
		aushärtbar, ausgehärtet	100					
	Aluminium-Gusslegierungen	≤ 12 % Si, ausgehärtet	80					
		≤ 12 % Si, aushärtbar, ausgehärtet	90					
		≤ 12 % Si, nicht aushärtbar	130					
	Kupfer und Kupferlegierungen (Bronze / Messing)	Automatenlegierung, Pb > 1%	–					
		Messing, Rotguss	–					
		Aluminiumbronze	90					
Kupfer und Elektrolytkupfer		100						
Nichtmetallische Werkstoffe	Duroplaste	100						
	Faserverstärkte Kunststoffe	–						
	Hartgummi	–						
S	Warmfeste Legierungen	Fe-Basis, geglüht	200	60–120				
		Fe-Basis, ausgehärtet	280	60–120				
		Ni- oder Co-Basis, geglüht	250	40–100				
		Ni- oder Co-Basis 30-58 HRC, gegossen	–	40–100				
		Ni- oder Co-Basis 1500-2200 Nmm ² , ausgehärtet	–	40–80				
Titanlegierungen, Alpha+Beta-Legierungen	Rein-Titan	Rm 440	40–80					
	ausgehärtet	Rm 1050	40–80					
H	Gehärteter Stahl	gehärtet und angelassen	55 HRC					
		gehärtet und angelassen	60 HRC					
	Hartguss	gegossen	400					
Gehärtetes Gusseisen	gehärtet und angelassen	55 HRC						

Die Tabellenwerte sind Richtwerte. Es kann notwendig sein, die Werte den jeweiligen Bearbeitungsbedingungen anzupassen.



Duo-Mill -10 – Cutting data recommendation for Square shoulder with SD..100408...

ISO	Material	Brinell-Hardness HB	Cutting speed V _c [m/min]						
			AK5315	AM5740	AP5215	AP5330	AP5430	AP5830+	AN1015
P	Unalloyed steel and cast steel	< 0,15 % C / hardened and tempered	125			100–220	100–220	100–220	
		0,15–0,45 % C / hardened and tempered	150–250			100–220	100–220	100–220	
		> 0,45 % C / hardened and tempered	300			100–220	100–220	100–220	
	Low alloyed steel and cast steel	annealed	180			80–220	80–220	80–220	
		hardened and tempered	250–300			80–220	80–220	80–220	
		hardened and tempered	350			80–220	80–220	80–220	
	High alloyed steel, high alloyed tool Steel and cast steel	annealed	200			80–180	80–180	80–180	
hardened and tempered		350			80–180	80–180	80–180		
Stainless steel Cast steel	ferritic, annealed	200			70–180	70–180	70–180		
	martensitic, hardened and tempered	325			70–180	70–180	70–180		
M	Stainless steel	ferritic, martensitic annealed	200	60–200					
		austenitic, chilled	180	60–200					
		Duplex, chilled	230	60–200					
		martensitic/austenitic, chilled	330	60–200					
K	Cast iron	pearlitic/ferritic	180	180–350					
		pearlitic/martensitic	260	140–280					
	Cast iron with nodular graphite	ferritisch	160	130–250					
		perlitisch	–	100–200					
Malleable cast iron	ferritic	130	150–320						
	pearlitic	230	120–250						
N	Aluminium alloys. long chipping	not heat treatable	60		440–1500			400–1500	
		heat treatable, heat treated	100		440–1500			400–1500	
	Casted aluminium alloys	≤ 12 % Si, heat treated	80		440–1500			400–1500	
		≤ 12 % Si, heat treatable, heat treated	90		330–1200			300–1200	
		≤ 12 % Si, not heat treatable	130		220–1000			200–1000	
	Copper and copper alloys, (Brass / Bronze)	Lead alloys, Pb > 1%	–		220–600			200–600	
		Brass, Bronze	–		275–1000			250–1000	
		Aluminium bronze	90		165–400			150–400	
		Copper and elektrolyte copper	100		330–800			300–800	
	Non ferrous materials	Duroplastic	100		90–1000			80–1000	
Re-inforced plastics		–		85–500			75–500		
Hard rubber		–		90–300			80–300		
S	High temperature resistant alloys	Fe-alloyed, annealed	200	20–60					
		Fe-alloyed, heat treated	280	20–60					
		Ni- or Co-alloyed, annealed	250	20–60					
		Ni- or Co-alloyed 30-58 HRC, casting	–	20–30					
		Ni- or Co-alloyed 1500-2200 Nmm ² , heat treated	–	20–30					
Titanium alloys	Pure titan	Rm 440	40–70						
Alpha- and Beta-alloys	heat treated	Rm 1050	20–40						
H	Hardened steel	hardened and tempered	55 HRC						
		hardened and tempered	60 HRC						
	Hard cast iron	casting	400						
Hardened cast iron	hardened and tempered	55 HRC							

The data given is only approximate values. It can be necessary to adjust this data to the individual machining operation.

Duo-Mill -15 – Cutting data recommendation for Square shoulder with SD..155012...

ISO	Material	Brinell-Hardness HB	Cutting speed V _c [m/min]						
			AK5315	AM5740	AP5215	AP5330	AP5430	AP5830+	AN1015
P	Unalloyed steel and cast steel	< 0,15 % C / hardened and tempered	125			100–220	100–220	100–220	
		0,15–0,45 % C / hardened and tempered	150–250			100–220	100–220	100–220	
		> 0,45 % C / hardened and tempered	300			100–220	100–220	100–220	
	Low alloyed steel and cast steel	annealed	180			80–220	80–220	80–220	
		hardened and tempered	250–300			80–220	80–220	80–220	
		hardened and tempered	350			80–220	80–220	80–220	
	High alloyed steel, high alloyed tool Steel and cast steel	annealed	200			80–220	80–220	80–220	
hardened and tempered		350			80–220	80–220	80–220		
Stainless steel Cast steel	ferritic, annealed	200			70–180	70–180	70–180		
	martensitic, hardened and tempered	325			70–180	70–180	70–180		
M	Stainless steel	ferritic, martensitic annealed	200	60–200					
		austenitic, chilled	180	60–200					
		Duplex, chilled	230	60–200					
		martensitic/austenitic, chilled	330	60–200					
K	Cast iron	pearlitic/ferritic	180	180–350					
		pearlitic/martensitic	260	140–280					
	Cast iron with nodular graphite	ferritisch	160	130–250					
		perlitisch	–	100–200					
Malleable cast iron	ferritic	130	150–320						
	pearlitic	230	120–250						
N	Aluminium alloys. long chipping	not heat treatable	60		440–1500			400–1500	
		heat treatable, heat treated	100		440–1500			400–1500	
	Casted aluminium alloys	≤ 12 % Si, heat treated	80		440–1500			400–1500	
		≤ 12 % Si, heat treatable, heat treated	90		330–1200			300–1200	
		≤ 12 % Si, not heat treatable	130		220–1000			200–1000	
	Copper and copper alloys, (Brass / Bronze)	Lead alloys, Pb > 1%	–		220–600			200–600	
		Brass, Bronze	–		275–1000			250–1000	
		Aluminium bronze	90		165–400			150–400	
		Copper and elektrolyte copper	100		330–800			300–800	
	Non ferrous materials	Duroplastic	100		90–1000			80–1000	
Re-inforced plastics		–		85–500			75–500		
Hard rubber		–		90–300			80–300		
S	High temperature resistant alloys	Fe-alloyed, annealed	200	20–60					
		Fe-alloyed, heat treated	280	20–60					
		Ni- or Co-alloyed, annealed	250	20–60					
		Ni- or Co-alloyed 30-58 HRC, casting	–	20–30					
		Ni- or Co-alloyed 1500-2200 Nmm ² , heat treated	–	20–30					
Titanium alloys	Pure titan	Rm 440	40–70						
Alpha- and Beta-alloys	heat treated	Rm 1050	20–40						
H	Hardened steel	hardened and tempered	55 HRC						
		hardened and tempered	60 HRC						
	Hard cast iron	casting	400						
Hardened cast iron	hardened and tempered	55 HRC							

The data given is only approximate values. It can be necessary to adjust this data to the individual machining operation.



Duo-Mill -10 – Cutting data recommendation for HFC-milling with SD..100415

2

ISO	Material	Brinell-Hardness HB	Cutting speed V _c [m/min]					
			AM15740	AP5325	AP5335	AP5340	AP5440	AP5830+
P	Unalloyed steel and cast steel	< 0,15% C / hardened and tempered	125	220-300	200-260	200-275	200-275	200-275
		0,15-0,45% C / hardened and tempered	150-250	220-300	200-260	200-275	200-275	200-275
		> 0,45% C / hardened and tempered	300	220-300	200-260	200-275	200-275	200-275
	Low alloyed steel and cast steel	annealed	180	220-300	200-260	200-275	200-275	200-275
		hardened and tempered	250-300	220-300	200-260	200-275	200-275	200-275
		hardened and tempered	350	220-300	200-260	200-275	200-275	200-275
	High alloyed steel, high alloyed tool Steel and cast steel	annealed	200	160-235	160-220	180-235	180-235	180-235
hardened and tempered		350	160-235	160-220	180-235	180-235	180-235	
Stainless steel Cast steel	ferritic, annealed	200	160-235	160-220	180-220	180-220	180-220	
	martensitic, hardened and tempered	325	160-235	160-220	180-220	180-220	180-220	
M	Stainless steel	ferritic, martensitic annealed	200	120-220				
		austenitic, chilled	180	120-220				
		Duplex, chilled	230	120-220				
		martensitic/austenitic, chilled	330	120-220				
K	Cast iron	pearlitic/ferritic	180	220-300				
		pearlitic/martensitic	260	200-280				
	Cast iron with nodular graphite	ferritisch	160	200-250				
		perlitisch	-	180-235				
Malleable cast iron	ferritic	130	220-300					
	pearlitic	230	200-250					
N	Aluminium alloys. long chipping	not heat treatable	60					
		heat treatable, heat treated	100					
	Casted aluminium alloys	≤ 12% Si, heat treated	80					
		≤ 12% Si, heat treatable, heat treated	90					
		≤ 12% Si, not heat treatable	130					
	Copper and copper alloys, (Brass / Bronze)	Lead alloys, Pb > 1%	-					
		Brass, Bronze	-					
Aluminium bronze		90						
Copper and elektrolyte copper		100						
Non ferrous materials	Duroplastic	100						
	Re-inforced plastics	-						
	Hard rubber	-						
S	High temperature resistant alloys	Fe-alloyed, annealed	200	60-120				
		Fe-alloyed, heat treated	280	60-120				
		Ni- or Co-alloyed, annealed	250	40-100				
		Ni- or Co-alloyed 30-58 HRC, casting	-	40-100				
		Ni- or Co-alloyed 1500-2200 Nmm ² , heat treated	-	40-80				
Titanium alloys	Pure titan	Rm 440	40-80					
	Alpha- and Beta-alloys	heat treated	Rm 1050	40-80				
H	Hardened steel	hardened and tempered	55 HRC					
		hardened and tempered	60 HRC					
	Hard cast iron	casting	400					
Hardened cast iron	hardened and tempered	55 HRC						

The data given is only approximate values. It can be necessary to adjust this data to the individual machining operation.

Duo-Mill -15 – Cutting data recommendation for HFC-milling with SD..155020

ISO	Material	Brinell-Hardness HB	Cutting speed V _c [m/min]				
			AM5740	AP5325	AP5340	AP5440	AP5830+
P	Unalloyed steel and cast steel	< 0,15 % C / hardened and tempered	125	220–300	200–275	200–275	200–275
		0,15–0,45 % C / hardened and tempered	150–250	220–300	200–275	200–275	200–275
		> 0,45 % C / hardened and tempered	300	220–300	200–275	200–275	200–275
	Low alloyed steel and cast steel	annealed	180	220–300	200–275	200–275	200–275
		hardened and tempered	250–300	220–300	200–275	200–275	200–275
		hardened and tempered	350	220–300	200–275	200–275	200–275
	High alloyed steel, high alloyed tool Steel and cast steel	annealed	200	180–235	180–235	180–235	180–235
hardened and tempered		350	180–235	180–235	180–235	180–235	
Stainless steel Cast steel	ferritic, annealed	200	180–235	180–235	180–220	180–220	
	martensitic, hardened and tempered	325	180–235	180–235	180–220	180–220	
M	Stainless steel	ferritic, martensitic annealed	200	120–220			
		austenitic, chilled	180	120–220			
		Duplex, chilled	230	120–220			
		martensitic/austenitic, chilled	330	120–220			
K	Cast iron	pearlitic/ferritic	180	220–300			
		pearlitic/martensitic	260	200–280			
	Cast iron with nodular graphite	ferritisch	160	200–250			
		perlitisch	–	180–235			
Malleable cast iron	ferritic	130	220–280				
	pearlitic	230	200–250				
N	Aluminium alloys. long chipping	not heat treatable	60				
		heat treatable, heat treated	100				
	Casted aluminium alloys	≤ 12 % Si, heat treated	80				
		≤ 12 % Si, heat treatable, heat treated	90				
		≤ 12 % Si, not heat treatable	130				
	Copper and copper alloys, (Brass / Bronze)	Lead alloys, Pb > 1%	–				
		Brass, Bronze	–				
		Aluminium bronze	90				
Copper and elektrolyte copper		100					
Non ferrous materials	Duroplastic	100					
	Re-inforced plastics	–					
	Hard rubber	–					
S	High temperature resistant alloys	Fe-alloyed, annealed	200	60–120			
		Fe-alloyed, heat treated	280	60–120			
		Ni- or Co-alloyed, annealed	250	40–100			
		Ni- or Co-alloyed 30-58 HRC, casting	–	40–100			
		Ni- or Co-alloyed 1500-2200 Nmm ² , heat treated	–	40–80			
Titanium alloys	Pure titan	Rm 440	40–80				
Alpha- and Beta-alloys	heat treated	Rm 1050	40–80				
H	Hardened steel	hardened and tempered	55 HRC				
		hardened and tempered	60 HRC				
	Hard cast iron	casting	400				
Hardened cast iron	hardened and tempered	55 HRC					

The data given is only approximate values. It can be necessary to adjust this data to the individual machining operation.



Duo-Mill -10 – Spallamento retto con inserto SD..100408...

ISO	Materiale	Durezza Brinell HB	Velocità di taglio V _c [m/min]						
			AK5315	AM5740	AP5215	AP5330	AP5430	AP5830+	AN1015
P	Acciai non legati	< 0,15 % C / bonificato	125			100-220	100-220	100-220	
		0,15-0,45 % C / bonificato	150-250			100-220	100-220	100-220	
		> 0,45 % C / bonificato	300			100-220	100-220	100-220	
	Acciai debolmente legati e Ghise acciaiose	ricotto	180			80-220	80-220	80-220	
		bonificato	250-300			80-220	80-220	80-220	
		bonificato	350			80-220	80-220	80-220	
	Acciai fortemente legati	ricotto	200			80-180	80-180	80-180	
Acciai da costruzione e Ghise acciaiose	bonificato	350			80-180	80-180	80-180		
Acciai inossidabili Ghisa acciaiosa	ferritico, ricotto	200			70-180	70-180	70-180		
	martensitico, bonificato	325			70-180	70-180	70-180		
M	Acciai inossidabili	ferritico, martensitico ricotto	200	60-200					
		austenitico, temprato	180	60-200					
		Duplex, temprato	230	60-200					
		martensitico/austenitico, temprato	330	60-200					
K	Ghisa grigia	perlitica/ferritico	180	180-350					
		perlitica/martensitico	260	140-280					
	Ghisa sferoidale	ferritico	160	130-250					
		perlitica	-	100-200					
Ghisa temprata	ferritico	130	150-320						
	perlitica	230	120-250						
N	Leghe di Alluminio stampato	non invecchiato	60		440-1500				400-1500
		temporabile, invecchiato	100		440-1500				400-1500
	Leghe di Alluminio da fusione	≤ 12 % Si, invecchiato	80		440-1500				400-1500
		≤ 12 % Si, temporabile, invecchiato	90		330-1200				300-1200
		≤ 12 % Si, non invecchiato	130		220-1000				200-1000
	Rame e Leghe di Rame (Bronzo / Ottone)	Automatici, Pb > 1 %	-		220-600				200-600
		Ottone, Bronzo	-		275-1000				250-1000
		Bronzoalluminio	90		165-400				150-400
		Rame e Rame Elettrolitico	100		330-800				300-800
	Materiali non metallici	Duroplastiche	100		90-1000				80-1000
Plastiche rinforzate		-		85-500				75-500	
Gomme dure		-		90-300				80-300	
S	Leghe resistenti al calore	Base-Fe, ricotto	200	20-60					
		Base-Fe, invecchiato	280	20-60					
		Base Ni o Co, ricotto	250	20-60					
		Base Ni o Co 30-58 HRC, da fusione	-	20-30					
		Base Ni o Co 1500-2200 Nmm ² , invecchiato	-	20-30					
Leghe di Titanio,	Titanio puro	Rm 440	40-70						
Leghe Alpha+Beta	invecchiato	Rm 1050	20-40						
H	Acciaio Temprato	temprato e rinvenuto	55 HRC						
		temprato e rinvenuto	60 HRC						
	Getti Temprati	da fusione	400						
Ghisa Temprata	temprato e rinvenuto	55 HRC							

Dati indicativi. Può essere necessario adattarli alle singole applicazioni.

Duo-Mill -15 – Spallamento retto con inserto SD..155012...

ISO	Materiale	Durezza Brinell HB	Velocità di taglio V _c [m/min]							
			AK5315	AM5740	AP5215	AP5330	AP5430	AP5830+	AN1015	
P	Acciai non legati	< 0,15 % C / bonificato	125				100-220	100-220	100-220	
		0,15-0,45 % C / bonificato	150-250				100-220	100-220	100-220	
		> 0,45 % C / bonificato	300				100-220	100-220	100-220	
	Acciai debolmente legati e Ghise acciaiose	ricotto	180				80-220	80-220	80-220	
		bonificato	250-300				80-220	80-220	80-220	
		bonificato	350				80-220	80-220	80-220	
	Acciai fortemente legati	ricotto	200				80-220	80-220	80-220	
Acciai da costruzione e Ghise acciaiose	bonificato	350				80-220	80-220	80-220		
Acciai inossidabili Ghisa acciaiosa	ferritico, ricotto	200				70-180	70-180	70-180		
	martensitico, bonificato	325				70-180	70-180	70-180		
M	Acciai inossidabili	ferritico, martensitico ricotto	200	60-200						
		austenitico, temprato	180	60-200						
		Duplex, temprato	230	60-200						
		martensitico/austenitico, temprato	330	60-200						
K	Ghisa grigia	perlitica/ferritico	180	180-350						
		perlitica/martensitico	260	140-280						
	Ghisa sferoidale	ferritico	160	130-250						
		perlitica	-	100-200						
Ghisa temprata	ferritico	130	150-320							
	perlitica	230	120-250							
N	Leghe di Alluminio stampato	non invecchiato	60		440-1500				400-1500	
		temporabile, invecchiato	100		440-1500				400-1500	
	Leghe di Alluminio da fusione	≤ 12 % Si, invecchiato	80		440-1500				400-1500	
		≤ 12 % Si, temporabile, invecchiato	90		330-1200				300-1200	
		≤ 12 % Si, non invecchiato	130		220-1000				200-1000	
	Rame e Leghe di Rame (Bronzo / Ottone)	Automatici, Pb > 1 %	-		220-600				200-600	
		Ottone, Bronzo	-		275-1000				250-1000	
		Bronzoalluminio	90		165-400				150-400	
		Rame e Rame Elettrolitico	100		330-800				300-800	
Materiali non metallici	Duroplastiche	100		90-1000				80-1000		
	Plastiche rinforzate	-		85-500				75-500		
	Gomme dure	-		90-300				80-300		
S	Leghe resistenti al calore	Base-Fe, ricotto	200	20-60						
		Base-Fe, invecchiato	280	20-60						
		Base Ni o Co, ricotto	250	20-60						
		Base Ni o Co 30-58 HRC, da fusione	-	20-30						
		Base Ni o Co 1500-2200 Nmm ² , invecchiato	-	20-30						
Leghe di Titanio,	Titanio puro	Rm 440	40-70							
Leghe Alpha+Beta	invecchiato	Rm 1050	20-40							
H	Acciaio Temprato	temprato e rinvenuto	55 HRC							
		temprato e rinvenuto	60 HRC							
	Getti Temprati	da fusione	400							
Ghisa Temprata	temprato e rinvenuto	55 HRC								

Dati indicativi. Può essere necessario adattarli alle singole applicazioni.



Duo-Mill -10 – HFC-Fresatura ad alto avanzamento con inserto SD..100415

ISO	Materiale	Durezza Brinell HB	Velocità di taglio V _c [m/min]					
			AM5740	AP5325	AP5335	AP5340	AP5440	AP5830+
P	Acciai non legati	< 0,15 % C / bonificato	125	220-300	200-260	200-275	200-275	200-275
		0,15-0,45 % C / bonificato	150-250	220-300	200-260	200-275	200-275	200-275
		> 0,45 % C / bonificato	300	220-300	200-260	200-275	200-275	200-275
	Acciai debolmente legati e Ghise acciaiose	ricotto	180	220-300	200-260	200-275	200-275	200-275
		bonificato	250-300	220-300	200-260	200-275	200-275	200-275
		bonificato	350	220-300	200-260	200-275	200-275	200-275
	Acciai fortemente legati	ricotto	200	160-235	160-220	180-235	180-235	180-235
Acciai da costruzione e Ghise acciaiose	bonificato	350	160-235	160-220	180-235	180-235	180-235	
Acciai inossidabili Ghisa acciaiosa	ferritico, ricotto	200	160-235	160-220	180-220	180-220	180-220	
	martensitico, bonificato	325	160-235	160-220	180-220	180-220	180-220	
M	Acciai inossidabili	ferritico, martensitico ricotto	200	120-220				
		austenitico, temprato	180	120-220				
		Duplex, temprato	230	120-220				
		martensitico/austenitico, temprato	330	120-220				
K	Ghisa grigia	perlitica/ferritico	180	220-300				
		perlitica/martensitico	260	200-280				
	Ghisa sferoidale	ferritico	160	200-250				
		perlitica	-	180-235				
Ghisa temprata	ferritico	130	220-300					
	perlitica	230	200-250					
N	Leghe di Alluminio stampato	non invecchiato	60					
		temporabile, invecchiato	100					
	Leghe di Alluminio da fusione	≤ 12 % Si, invecchiato	80					
		≤ 12 % Si, temporabile, invecchiato	90					
		≤ 12 % Si, non invecchiato	130					
	Rame e Leghe di Rame (Bronzo / Ottone)	Automatici, Pb > 1 %	-					
		Ottone, Bronzo	-					
Bronzoalluminio		90						
Rame e Rame Elettrolitico		100						
Materiali non metallici	Duroplastiche	100						
	Plastiche rinforzate	-						
	Gomme dure	-						
S	Leghe resistenti al calore	Base-Fe, ricotto	200	60-120				
		Base-Fe, invecchiato	280	60-120				
		Base Ni o Co, ricotto	250	40-100				
		Base Ni o Co 30-58 HRC, da fusione	-	40-100				
		Base Ni o Co 1500-2200 Nmm ² , invecchiato	-	40-80				
Leghe di Titanio,	Titanio puro	Rm 440	40-80					
Leghe Alpha+Beta	invecchiato	Rm 1050	40-80					
H	Acciaio Temprato	temprato e rinvenuto	55 HRC					
		temprato e rinvenuto	60 HRC					
	Getti Temprati	da fusione	400					
Ghisa Temprata	temprato e rinvenuto	55 HRC						

Dati indicativi. Può essere necessario adattarli alle singole applicazioni.

Duo-Mill -15 – HFC-Fresatura ad alto avanzamento con inserto SD..155020

ISO	Materiale	Durezza Brinnell HB	Velocità di taglio V _c [m/min]				
			AM5740	AP5325	AP5340	AP5440	AP5830+
P	Acciai non legati	< 0,15 % C / bonificato	125	220-300	200-275	200-275	200-275
		0,15-0,45 % C / bonificato	150-250	220-300	200-275	200-275	200-275
		> 0,45 % C / bonificato	300	220-300	200-275	200-275	200-275
	Acciai debolmente legati e Ghise acciaiose	ricotto	180	220-300	200-275	200-275	200-275
		bonificato	250-300	220-300	200-275	200-275	200-275
	bonificato	350	220-300	200-275	200-275	200-275	
Acciai fortemente legati	ricotto	200	180-235	180-235	180-235	180-235	
Acciai da costruzione e Ghise acciaiose	bonificato	350	180-235	180-235	180-235	180-235	
Acciai inossidabili Ghisa acciaiosa	ferritico, ricotto	200	180-235	180-235	180-220	180-220	
	martensitico, bonificato	325	180-235	180-235	180-220	180-220	
M	Acciai inossidabili	ferritico, martensitico ricotto	200	120-220			
		austenitico, temprato	180	120-220			
		Duplex, temprato	230	120-220			
		martensitico/austenitico, temprato	330	120-220			
K	Ghisa grigia	perlitica/ferritico	180	220-300			
		perlitica/martensitico	260	200-280			
	Ghisa sferoidale	ferritico	160	200-250			
		perlitica	-	180-235			
Ghisa temprata	ferritico	130	220-280				
	perlitica	230	200-250				
N	Leghe di Alluminio stampato	non invecchiato	60				
		temporabile, invecchiato	100				
	Leghe di Alluminio da fusione	≤ 12 % Si, invecchiato	80				
		≤ 12 % Si, temporabile, invecchiato	90				
		≤ 12 % Si, non invecchiato	130				
	Rame e Leghe di Rame (Bronzo / Ottone)	Automatici, Pb > 1 %	-				
		Ottone, Bronzo	-				
Bronzoalluminio		90					
Materiali non metallici	Rame e Rame Elettrolitico	100					
	Duroplastiche	100					
	Plastiche rinforzate	-					
S	Leghe resistenti al calore	Gomme dure	-				
		Base-Fe, ricotto	200	60-120			
		Base-Fe, invecchiato	280	60-120			
		Base Ni o Co, ricotto	250	40-100			
		Base Ni o Co 30-58 HRC, da fusione	-	40-100			
Base Ni o Co 1500-2200 Nmm ² , invecchiato	-	40-80					
Leghe di Titanio,	Titanio puro	Rm 440	40-80				
Leghe Alpha+Beta	invecchiato	Rm 1050	40-80				
H	Acciaio Temprato	temprato e rinvenuto	55 HRC				
		temprato e rinvenuto	60 HRC				
	Getti Temprati	da fusione	400				
Ghisa Temprata	temprato e rinvenuto	55 HRC					

Dati indicativi. Può essere necessario adattarli alle singole applicazioni.

2

Wendeschnidplatte Duo-Mill -10 – Schnittdatenrichtwerte

Indexable insert Duo-Mill -10 – Cutting data recommendation

Inserto Duo-Mill -10 – Parametri di taglio consigliati

ISO	Eckfräsen/Square shoulder/Fresatura a Spallamento Retto	Mittlere Bearbeitung Medium machining Media asportazione			Schrupp-Bearbeitung Rough machining Sgrossatura		
		v_c [m/min]	f_z [mm]	a_p [mm]	v_c [m/min]	f_z [mm]	a_p [mm]
	Werkstoff/Material/Materiale						
P	Stahl/Steel/Acciaio	120–220	0,1–0,20	< 3	60–180	0,1–0,25	< 5
M	Rostfreier Stahl/Stainless steel/Acciaio inossidabile	90–200	0,1–0,35	< 3	60–120	0,1–0,25	< 5
K	Guss/Cast iron/Ghisa	170–350	0,1–0,20	< 3	120–200	0,1–0,25	< 5
N	NE-Metalle/Non ferrous materials/Materiali non ferrosi	400–1500	0,1–0,30	< 3	400–1000	0,1–0,20	< 8
S	Hochwarmfest/High temperature resistant alloys/Leghe resistenti al calore	40–120	0,1–0,20	< 3	30–90	0,1–0,20	< 5

ISO	HFC-Fräsen/HFC-milling/HFC-Fresatura ad alto avanzamento	v_c [m/min]	f_z [mm]	a_p [mm]
	Werkstoff/Material/Materiale			
P	Stahl/Steel/Acciaio	180–300	0,2–2,5	0,25–1,5
M	Rostfreier Stahl/Stainless steel/Acciaio inossidabile	120–220	0,2–1,5	0,25–1,5
K	Guss/Stainless steel/Ghisa	200–300	0,3–2,5	0,25–1,5
S	Hochwarmfest/High temperature resistant alloys/Leghe resistenti al calore	40–120	0,2–1,0	0,25–1,2

Wendeschnidplatte Duo-Mill -15 – Schnittdatenrichtwerte

Indexable insert Duo-Mill -15 – Cutting data recommendation

Inserto Duo-Mill -15 – Parametri di taglio consigliati

ISO	Eckfräsen/Square shoulder/Fresatura a Spallamento Retto	Mittlere Bearbeitung Medium machining Media asportazione			Schrupp-Bearbeitung Rough machining Sgrossatura		
		v_c [m/min]	f_z [mm]	a_p [mm]	v_c [m/min]	f_z [mm]	a_p [mm]
	Werkstoff/Material/Materiale						
P	Stahl/Steel/Acciaio	120–220	0,1–0,35	< 5	60–180	0,1–0,25	< 10
M	Rostfreier Stahl/Stainless steel/Acciaio inossidabile	90–200	0,1–0,35	< 5	60–120	0,1–0,25	< 10
K	Guss/Cast iron/Ghisa	170–350	0,1–0,20	< 5	120–200	0,1–0,25	< 10
N	NE-Metalle/Non ferrous materials/Materiali non ferrosi	400–1500	0,1–0,30	< 5	400–1000	0,1–0,20	< 12
S	Hochwarmfest/High temperature resistant alloys/Leghe resistenti al calore	40–120	0,1–0,20	< 5	30–90	0,1–0,20	< 10

ISO	HFC-Fräsen/HFC-milling/HFC-Fresatura ad alto avanzamento	v_c [m/min]	f_z [mm]	a_p [mm]
	Werkstoff/Material/Materiale			
P	Stahl/Steel/Acciaio	180–300	0,5–2,5	0,5–2,5
M	Rostfreier Stahl/Stainless steel/Acciaio inossidabile	120–220	0,5–2,0	0,5–2,5
K	Guss/Stainless steel/Ghisa	130–300	0,5–2,5	0,5–2,5
S	Hochwarmfest/High temperature resistant alloys/Leghe resistenti al calore	40–120	0,5–1,5	0,5–2,0

Die Tabellenwerte sind Richtwerte. Es kann notwendig sein, die Werte den jeweiligen Bearbeitungsumständen anzupassen.

The data given is only approximate values. It can be necessary to adjust this data to the individual machining operation.

Dati indicativi. Può essere necessario adattarli alle singole applicazioni.

ISO-Application area
ISO-Campi di applicazione

ISO	Hartmetall beschichtet Carbide coated Metallo duro rivestito	Hartmetall unbeschichtet Carbide uncoated Metallo duro non rivestito	Schneidstoff Cutting material Materiale da taglio	Anwendung Application Parametri
P Stahl, Stahlguss, langspanender Temperguss <i>Steel, cast steel, long chipping malleable iron</i> Acciaio, acciaio colato, ghisa temprata a truciolo lungo	10		Zähigkeit Toughness Tenacità Verschleißbeständigkeit Resistenza all'usura	Vorschub Feed rate Avanzamento Schnittgeschwindigkeit Cutting speed Velocità di taglio
	20	AP5325		
	30	AP5330		
	30	AP5430		
	40	AP5340		
40	AP5440			
40	AP5335			
40	AP5830+			
M Rostfreier Stahl, Stahlguss, Manganstahl, Automatenstahl <i>Stainless steel, cast steel, manganese steel, free cutting steel</i> Acciaio inossidabile, acciaio colato, acciaio al manganese, ghisa legata, ghisa temprata, acciaio automatico, leghe refrattarie	10		Zähigkeit Toughness Tenacità Verschleißbeständigkeit Resistenza all'usura	Vorschub Feed rate Avanzamento Schnittgeschwindigkeit Cutting speed Velocità di taglio
	20			
	30			
	40	AM5740		
K Grauguss, Kokillenhartguss, kurzspanender Temperguss <i>Grey cast iron, chilled hard cast iron, short chipping malleable iron</i> Ghisa grigia, ghisa fusa in conchiglia, ghisa temprata a truciolo corto, acciaio temprato, metalli non ferrosi, plastica, legno	10		Zähigkeit Toughness Tenacità Verschleißbeständigkeit Resistenza all'usura	Vorschub Feed rate Avanzamento Schnittgeschwindigkeit Cutting speed Velocità di taglio
	20	AP5325		
	30	AM5315		
	40			
N Aluminium und Al-Legierungen, nichtmetallische Werkstoffe <i>Aluminium and Al-alloys, non ferrous materials</i> Alluminio e leghe di alluminio, materiali non metallici	10	AP5215	Zähigkeit Toughness Tenacità Verschleißbeständigkeit Resistenza all'usura	Vorschub Feed rate Avanzamento Schnittgeschwindigkeit Cutting speed Velocità di taglio
	20			
	30	AM1015		
	40			
S Warmfeste Legierungen, Titanlegierungen <i>High temperature resistant alloys, Titanium alloys</i> Leghe refrattarie, leghe di titanio	10		Zähigkeit Toughness Tenacità Verschleißbeständigkeit Resistenza all'usura	Vorschub Feed rate Avanzamento Schnittgeschwindigkeit Cutting speed Velocità di taglio
	20			
	30	AM5740		
	40			
H Gehärteter Stahl, Hartguss <i>Hardened Steel, hard cast iron</i> Acciaio temprato, ghisa temprata	10		Zähigkeit Toughness Tenacità Verschleißbeständigkeit Resistenza all'usura	Vorschub Feed rate Avanzamento Schnittgeschwindigkeit Cutting speed Velocità di taglio
	20			
	30			
	40			

2

Hauptanwendungsbereich / Main application area / Applicazione principale

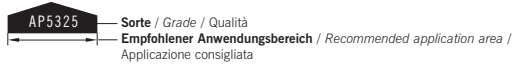

Nebenanwendungsbereich / Secondary application area / Applicazione secondaria

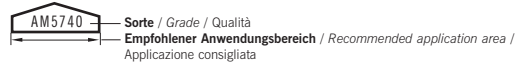

Einsatzdaten WSP-10 Eckfräser

Cutting data indexable inserts SD...10... Square shoulder

Parametri di taglio suggeriti con inserti SD...10... Fresatura a Spallamento Retto

Zirkulares Eintauchen / Helical interpolation / Fresatura circolare

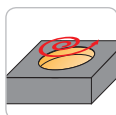
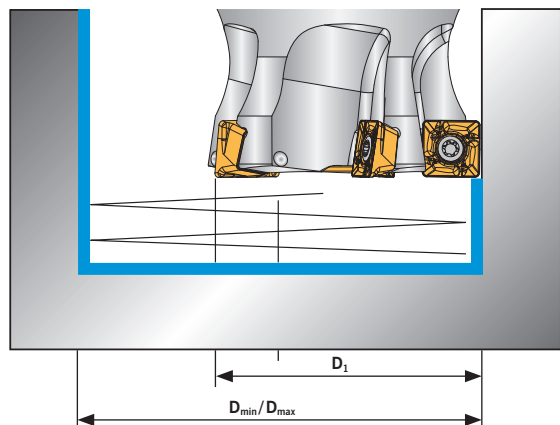

D ₁	D _{min}	D _{max}
25	35	48
32	49	62
40	65	78
50	85	98
63	111	124
80	145	158
100	185	198
125	235	248
160	305	318

D_{min} = kleinster Bohrungsdurchmesser
 minimum bore diameter
 diametro minimo di foro

D_{max} = größter Bohrungsdurchmesser für ebene Bodenflächen
 maximum bore diameter for flat area
 diametro massimo foro per parte piana

Axiales Eintauchen / Plunge milling / Fresatura assiale

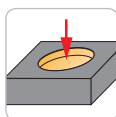
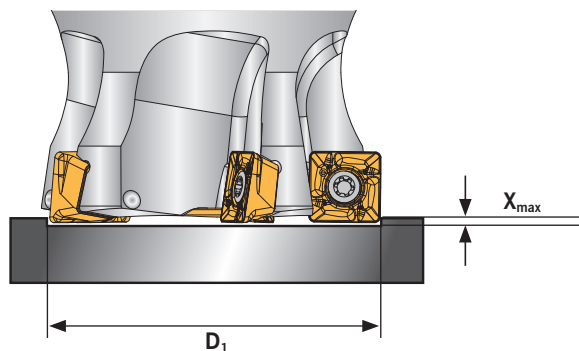

D ₁	X _{max}
D25–D160	1,8 mm

Schräges Eintauchen / Ramping / Fresatura in rampa

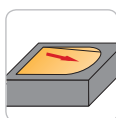
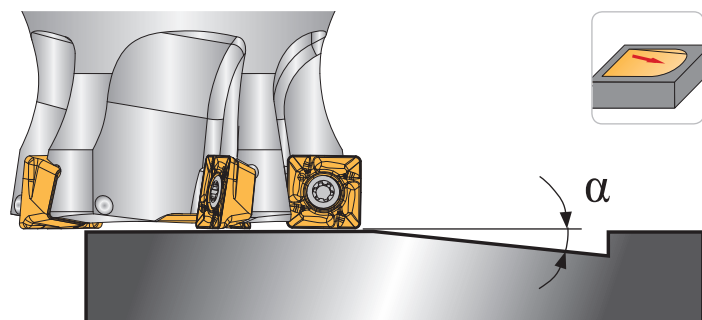

D ₁	α	Mindest-Verfahrweg Minimum travel Corsa minima
25	10,2	10
32	6,0	17
40	4,0	25
50	2,9	35
63	2,1	48
80	1,6	65
100	1,2	85
125	0,9	110
160	0,7	145

2

Einsatzdaten WSP-15 Eckfräser

Cutting data indexable inserts SD...15... Square shoulder
 Parametri di taglio suggeriti con inserti SD...15... Fresatura a Spallamento Retto

Zirkulares Eintauchen / Helical interpolation / Fresatura circolare

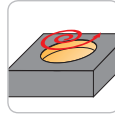
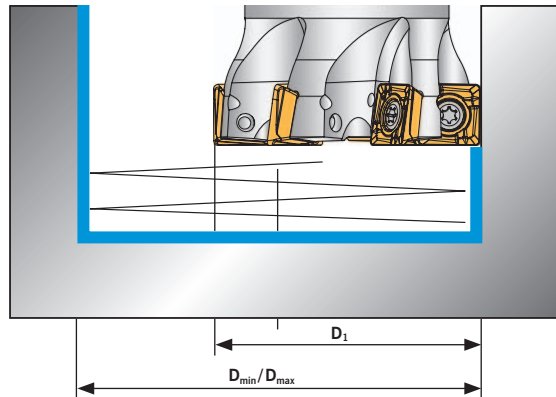

D ₁	D _{min}	D _{max}
50	77,5	98
63	103,5	124
80	137	158
100	177,5	198
125	227	248
160	297	318

D_{min} = kleinster Bohrungsdurchmesser
minimum bore diameter
 diametro minimo di foro

D_{max} = größter Bohrungsdurchmesser für ebene Bodenflächen
maximum bore diameter for flat area
 diametro massimo foro per parte piana



Axiales Eintauchen / Plunge milling / Fresatura assiale

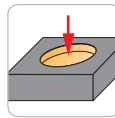
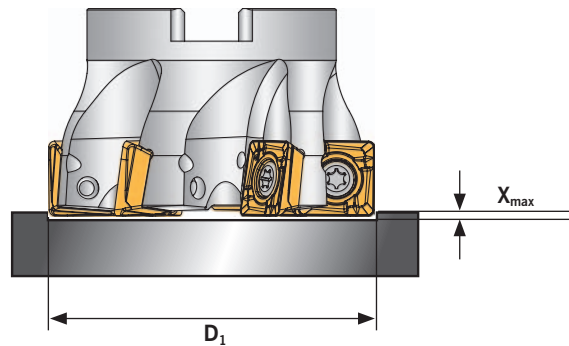

D ₁	X _{max}
D50–D160	2,0 mm

Schräges Eintauchen / Ramping / Fresatura in rampa

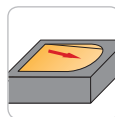
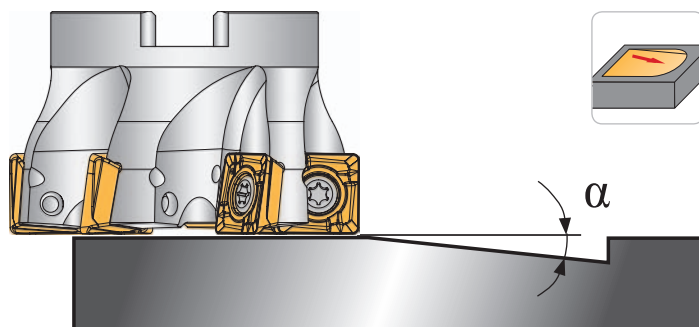

D ₁	α	Mindest-Verfahrweg Minimum travel Corsa minima
50	4,2	27
63	2,8	40
80	2,0	58
100	1,5	78
125	1,1	103
160	0,8	138

Einsatzdaten WSP-10 HFC-Fräser

Cutting data indexable inserts SD...10... HFC-milling

Parametri di taglio suggeriti con inserti SD...10... HFC-Fresatura

Zirkulares Eintauchen / Helical interpolation / Fresatura circolare

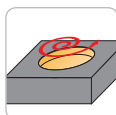
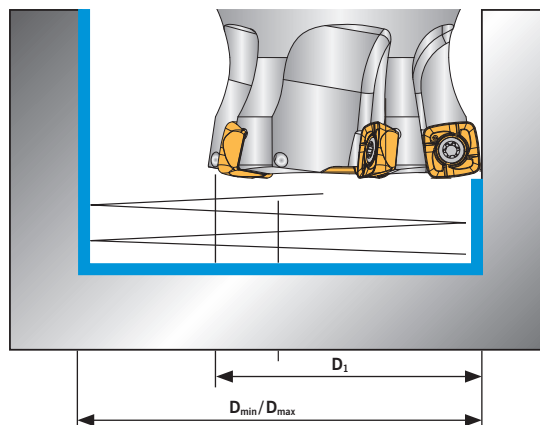

D ₁	D _{min}	D _{max}
25	39	48
32	53	62
40	69	78
50	89	98
63	115	124
80	149	158
100	189	198
125	239	248
160	309	318

D_{min} = kleinster Bohrungsdurchmesser

minimum bore diameter
diametro minimo di foro

D_{max} = größter Bohrungsdurchmesser für ebene Bodenflächen

maximum bore diameter for flat area
diametro massimo foro per parte piana

Axiales Eintauchen / Plunge milling / Fresatura assiale

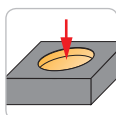
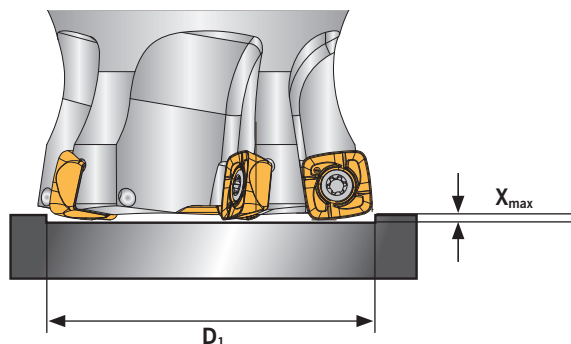

D ₁	X _{max}
D25–D160	1,2 mm

Schräges Eintauchen / Ramping / Fresatura in rampa

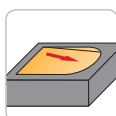
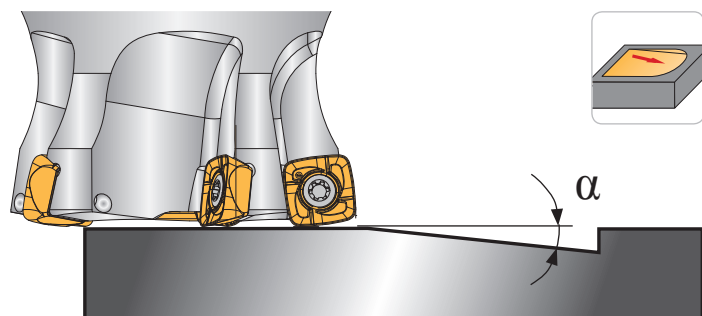

D ₁	α	Mindest-Verfahrweg Minimum travel Corsa minima
25	4,9	14
32	3,2	21
40	2,3	29
50	1,8	39
63	1,3	52
80	1,0	69
100	0,75	89
125	0,6	114
160	0,4	149

Einsatzdaten WSP-15 HFC-Fräser

Cutting data indexable inserts SD...15... HFC-milling

Parametri di taglio suggeriti con inserti SD...15... HFC-Fresatura

Zirkulares Eintauchen / Helical interpolation / Fresatura circolare

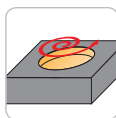
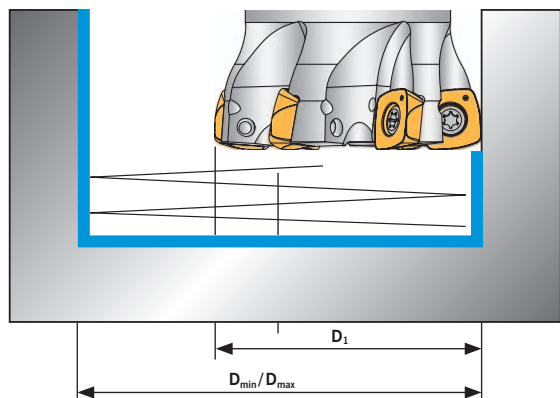

D ₁	D _{min}	D _{max}
50	82	98
63	108	124
80	142	158
100	182	198
125	232	248
160	302	318

D_{min} = **kleinster Bohrungsdurchmesser**

minimum bore diameter

diametro minimo di foro

D_{max} = **größter Bohrungsdurchmesser für ebene Bodenflächen**

maximum bore diameter for flat area

diametro massimo foro per parte piana

2

Axiales Eintauchen / Plunge milling / Fresatura assiale

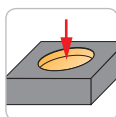
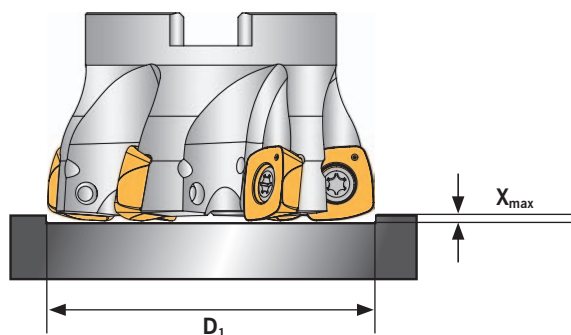

D ₁	X _{max}
D50–D160	1,8 mm

Schräges Eintauchen / Ramping / Fresatura in rampa

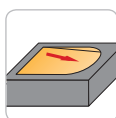
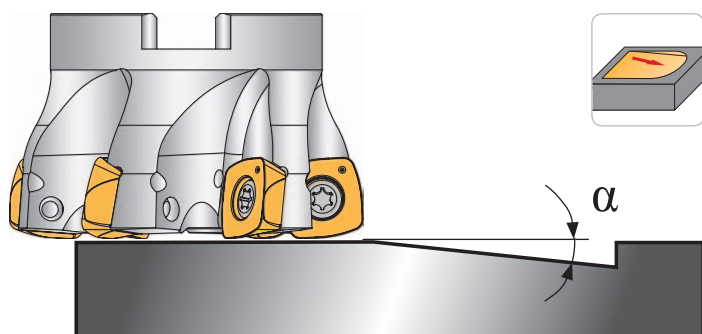

D ₁	α	Mindest-Verfahrweg <i>Minimum travel</i> <i>Corsa minima</i>
50	3,2	32
63	2,3	45
80	1,66	62
100	1,25	82
125	0,96	107
160	0,72	142

Planfräsen extrem!*Extreme milling!*

Fresatura con parametri estremi!

Speziell entwickelte Hartmetallsorten und die optimal abgestimmte Spanleitstufe ermöglichen diese enorme Leistungsfähigkeit. Optimierte Beschichtungen garantieren maximales Zeitspanvolumen.

To achieve performance like this we apply especially developed carbide grades and optimized chip breaker geometries. Latest coating technology guarantees maximum tool performance.

Per ottenere tali risultati sono stati sviluppati gradi speciali e geometrie di rompitruciolo ottimizzate a queste applicazioni. La più recente tecnologia di rivestimento garantisce inoltre il massimo delle prestazioni e durate.

Duo-Mill -10 Vorschübe bis zu 2 mm pro Zahn

Feed rates up to 2 mm per tooth / con avanzamenti fino a 2 mm per tagliente!

2

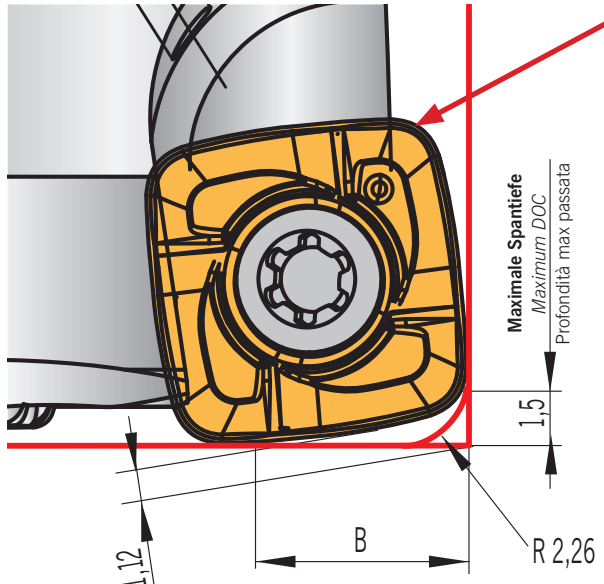

Markierung:
Um einen optimalen Plan- und Rundlauf zu erzielen, sollte die Wendeschneidplatte in jedem Sitz mit gleicher Einbaulage montiert werden. Drehung nach Verschleiß immer im Uhrzeigersinn.

Marking:
In order to achieve the optimum axial and radial runout always mount indexable inserts in same position. When worn always turn clockwise.

Marcatura inserto:
Per ottenere il posizionamento di tutti gli inserti riducendo al minimo errori radiali od assiali assicurarsi che tutti gli inserti vengano montati nella medesima posizione rispetto alla marcatatura. Al cambio tagliente ruotare gli inserti in senso orario.

Restwerkstoff der Kontur beim Eck- und Nutfräsen.
Material left over when face and slot milling.
Materiale lasciato non lavorato in spianatura e svuotamento di cave.

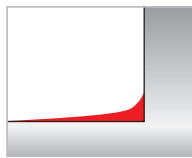

Maximale Spantiefe / Maximum DOC / Profondità max passata = 1,5 mm
Programmierradius / Programming radius / Raggio programmazione = R2,26
SK-Länge / SK-length / Lunghezza tagliente = 9,6 mm
B = 7,6 mm

Duo-Mill -15 Vorschübe bis zu 2,5 mm pro Zahn

Feed rates up to 2.5 mm per tooth / con avanzamenti fino a 2,5 mm per tagliente!

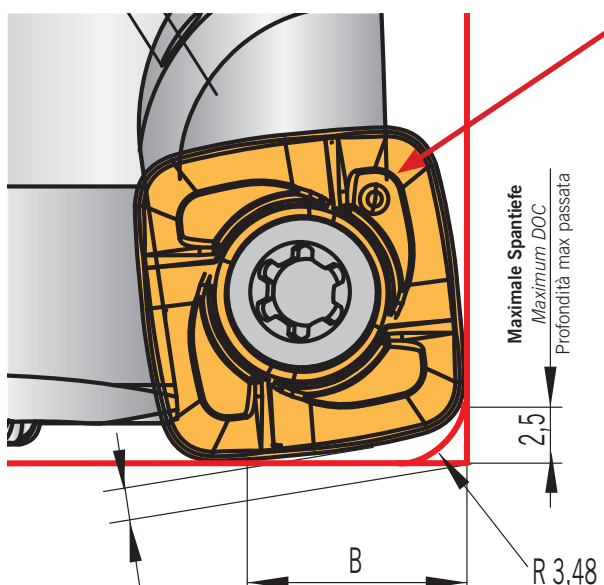

Markierung:
Um einen optimalen Plan- und Rundlauf zu erzielen, sollte die Wendeschneidplatte in jedem Sitz mit gleicher Einbaulage montiert werden. Drehung nach Verschleiß immer im Uhrzeigersinn.

Marking:
In order to achieve the optimum axial and radial runout always mount indexable inserts in same position. When worn always turn clockwise.

Marcatura inserto:
Per ottenere il posizionamento di tutti gli inserti riducendo al minimo errori radiali od assiali assicurarsi che tutti gli inserti vengano montati nella medesima posizione rispetto alla marcatatura. Al cambio tagliente ruotare gli inserti in senso orario.

Restwerkstoff der Kontur beim Eck- und Nutfräsen.
Material left over when face and slot milling.
Materiale lasciato non lavorato in spianatura e svuotamento di cave.

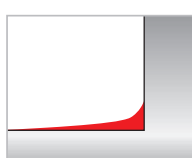

Maximale Spantiefe / Maximum DOC / Profondità max passata = 2,5 mm
Programmierradius / Programming radius / Raggio programmazione = R3,48
SK-Länge / SK-length / Lunghezza tagliente = 14,20 mm
B = 11,00 mm

HFC-Fräsen Berechnungsformel der Schnittbreite für ebene Flächen:

HFC-milling calculation formula for cutting widths on plain surfaces:

Formula di calcolo per la larghezza di taglio su superficie piana con fresatura ad alto avanzamento:

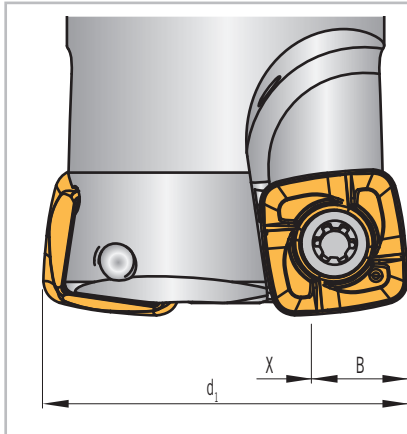

$d_1 - 2 \times B =$
Schnittbreite / Cutting width / profondità passata X [mm]

Beispiel / Example / Esempio
Duo-Mill -10 –
Fräser / Cutter / Fresatura D80:
Durchmesser / Diameter / Diametro
 $d_1 = 25 \text{ mm} - 160 \text{ mm}$
 $B = 7,6 \text{ mm}$
 $80 \text{ mm} - (2 \times 7,6 \text{ mm}) = 64,8 \text{ mm}$

Beispiel / Example / Esempio
Duo-Mill -15 –
Fräser / Cutter / Fresatura D80:
Durchmesser / Diameter / Diametro
 $d_1 = 25 \text{ mm} - 160 \text{ mm}$
 $B = 11,00 \text{ mm}$
 $80 \text{ mm} - (2 \times 11,00 \text{ mm}) = 58 \text{ mm}$

Vorteile HFC-Fräsen:

- sehr hohe Abtragsraten und extrem leichter Schnitt
- maximale Prozesssicherheit im unterbrochenen Schnitt durch sichere Positionierung der Wendeschneidplatte
- Schonung der Maschinenspindel durch geringe Umschlingung der Wendeschneidplatte (Radialkräfte werden minimiert)

Advantages HFC-milling:

- Very high removal rates and extremely soft cutting
- Maximum process reliability during interrupted cut due to the secure positioning of the indexable insert
- Preserving of the machine spindle because of reduced circumference of the indexable insert (radial powers are minimized)

Vantaggi HFC-Fresatura:

- Taglio morbido ed elevato volume di asportazione truciolo.
- Massima affidabilità di processo con taglio interrotto grazie al posizionamento rigido e sicuro dell'inserto.
- Minor sollecitazioni sul mandrino grazie alla ridotta superficie di contatto (riduzione delle forze radiali).

Einsatz-Beispiel FDC: Grundsätzlich sollte die kürzeste Ausspannlänge gewählt werden.

Application example FDC: Preferably always keep overhang as short as possible.

Esempio di applicazione FDC: Utilizzare sempre la soluzione di utensile più compatta possibile.

Werkstoff-Festigkeit Material hardness Durezza del materiale	1000 N/mm²
Vorschub pro Zahn (f_z) Feed per tooth Avanzamento per dente	0,12 mm – 0,18 mm
Schnittgeschwindigkeit (v_c) Cutting speed Velocità di taglio	100 m/min

Frässpindel / Milling adaptor / Mandrino SK50:	
Spannung mit Weldon-Aufnahme in Weldon holder Lavorazione con attacco Weldon	max. Schnitttiefe (a_p) = 4 mm max DOC max. prof. passata (a _p) = 4 mm
Spannung mit Spannzange in collet chuck Lavorazione con attacco a manicotto	max. Schnitttiefe (a_p) = 4 mm max DOC max. prof. passata (a _p) = 4 mm
Frässpindel / Milling adaptor / Mandrino SK40:	
Spannung mit Weldon-Aufnahme in Weldon holder Lavorazione con attacco Weldon	max. Schnitttiefe (a_p) = 2 mm max DOC max. prof. passata (a _p) = 2 mm
Spannung mit Spannzange in collet chuck Lavorazione con attacco a manicotto	max. Schnitttiefe (a_p) = 4 mm max DOC max. prof. passata (a _p) = 4 mm

HINWEIS:

Die Tabellenwerte sind Richtwerte. Es kann notwendig sein, die Werte den jeweiligen Bearbeitungsumständen anzupassen. Besonders folgende Einflussgrößen müssen hier berücksichtigt werden:

- Maschinenleistung
- Spindel / Aufnahme
- Ausspannlänge
- Aufspannung
- Bearbeitungsart

INFO:

The charts are recommendations only. It may be necessary to adjust the cutting data according to:

- Machine power
- Spindle and shank
- Overhang length
- Material clamping
- Component stability

NOTA:

I valori indicati in tabella sono indicativi e considerati in ottimali condizioni di lavoro. Può essere necessario adattarli in base alle diverse condizioni di lavoro quali:

- Caratteristiche della macchina (stabilità, potenza, precisione)
- Dimensione e tipologia del mandrino
- Bloccaggio del pezzo
- Bloccaggio e dimensione dell'utensile
- Condizioni generali di lavoro

Rundum überzeugend: ARNO-Gewindefräser aus Vollhartmetall für die Bearbeitung von Stahl, Aluminium und NE-Metallen.

*Solid carbide thread mills for steel, aluminium and
none ferrous materials.*

Frese a filettare per tutti i tipi di filettature e
per lavorazione di acciai e ghise.



ARNO® VOLLHARTMETALL GEWINDEFÄSER

TiAlN beschichtete Gewindefräser aus Feinstkorn-Hartmetall bieten Ihnen eine optimale, gleichmäßige Gewindegüte sowie eine hohe Verschleißfestigkeit.

Fine grain solid carbide cutters with TiAlN coating, some with through tool coolant and chamfering edge.

Frese a filettare in metallo duro integrale rivestite per lavorare Acciaio, ghisa, Acciaio inossidabile, leghe esotiche o refrattarie e acciai temprati fino a 50 HRC.

Weitere Vollhartmetall-Fräser finden Sie im aktuellen Tiefstpreiskatalog oder unter:

You will find more solid carbide cutters in our "Special Price" catalogue:

La gamma completa di frese in MDI è disponibile sul catalogo dedicato "Catalogo Promozione" oppure visitando il sito:

www.arno.de

ARNO®-Frässystem ROC-Mill

- Systemvorstellung
- Bezeichnungssystem
- Werkzeugauswahl
- Trägerwerkzeuge
- Wendeschneidplatten
 - Geometriebeschreibung
 - Sortenbeschreibung
- Ersatzteile
- Schnittwerte
- Anwendungshinweise

ARNO®-ROC-Mill milling system

- *System introduction*
- *Designation system*
- *Tool shank options*
- *Holder*s
- *Indexable inserts*
 - *Geometry description*
 - *Grade description*
- *Spare parts*
- *Cutting data*
- *Application reference*

ARNO®-Sistema di fresatura ROC-Mill

- Caratteristiche del sistema **88 – 89**
- Sistema di numerazione **90**
- Tipologie di attacco utensile **91**
- Corpi fresa **92 – 93**
- Inserti **94 – 96**
 - Descrizione delle Geometrie **94**
 - Descrizione delle Qualità **95**
- Ricambi **97**
- Parametri di taglio **98 – 102**
- Suggerimenti tecnici **103 – 105**



ARNO®-Frässystem ROC-Mill: vereint runde und oktagonale Wendeschneidplatten in einem Plattensitz.

ARNO®-Milling system ROC-Mill: accepts both round and octagonal inserts in the same insert pocket.

ARNO®-Sistema di Fresatura ROC-Mill: permette il montaggio di inserti tondi od ottagonali sul medesimo corpo fresa.

2 verschiedene Wendeschneidplatten mit jeweils 8 Schneidkanten im gleichen Plattensitz spannen und somit die kompletten Anschaffungskosten für ein zusätzliches Trägerwerkzeugsystem sparen?

Mit dem neuen ARNO®-Frässystem ROC-Mill kein Problem. Der positiv weichschneidende Planfräser, der eine Rundplatte und eine oktagonale Wendeschneidplatte in einem Plattensitz vereint, macht dies möglich.

2 different indexable inserts, one with 8 cutting edges and a round insert for the same insert pocket, can this save you buying two tools?

No problem with the new ARNO® ROC-Mill milling system, the soft cutting positive face mill accepts both the 8-edged octagonal and the round insert in the same insert pocket.

2 diversi inserti, entrambi con 8 taglienti utili, uno ottagonale ed uno tondo. Un notevole risparmio con due utensili in uno!

Con il nuovo sistema di fresatura ARNO® ROC-Mill, grazie alle spoglie positive di taglio, si riducono molti problemi di lavorazione anche grazie alla flessibilità di utilizzo con inserto ottagonale o tondo.

1 Grundhalter für 2 verschiedene Bearbeitungsmöglichkeiten durch einfachen Austausch der Wendeschneidplatte.

1 holder for 2 different applications by a simple change of indexable insert.

1 corpo utensile per 2 applicazioni: basta cambiare l'inserto!

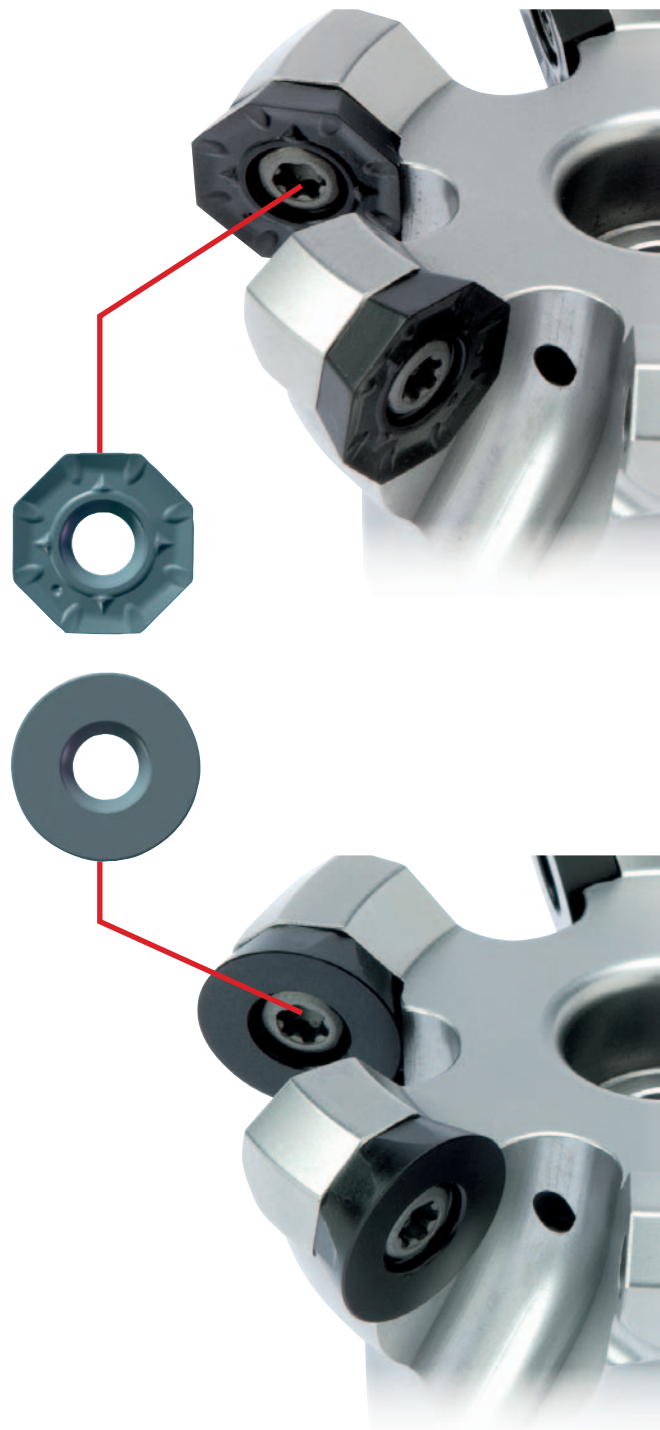

Vorteile durch die Kombination mit einem Trägerwerkzeug

Application features of the ROC-Mill combination

Caratteristiche delle varie combinazioni ROC-Mill



Planfräsen mit 8 Schneiden Face milling with 8 edges (doc) Spianatura con 8 taglienti	< 2,34	< 4
Planfräsen mit 4 Schneiden Face milling with 4 edges (doc) Spianatura con 4 taglienti	< 8,0	< 10
Planfräsen Guss-Schmiedekruste Face milling of forged crusts Spianatura di crosta	++	
Radiusfräsen – Kopierfräsen Copy milling Fresatura di copiatura	++	
Zirkularfräsen mit Querbohrung Circular milling Fresatura circolare	++	+
Vorschub pro Zahn f_z bei a_p 3 mm Feed rate per tooth at 3 mm doc Avanzamento a tagliente f_z con a_p 3 mm	0,6	0,3

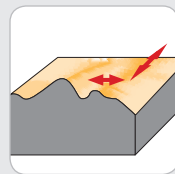

Kopierfräsen / Copy milling /
Fresatura di copiatura

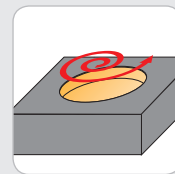

Zirkularfräsen / Circular milling /
Fresatura circolare

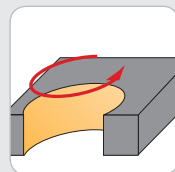

Zirkularfräsen / Circular milling /
Fresatura circolare

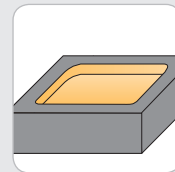

Taschenfräsen / Face milling /
Fresatura assiale

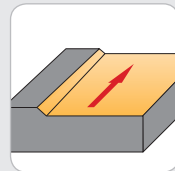

Planfräsen / Face milling /
Spianatura

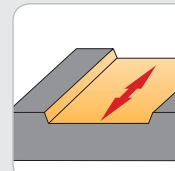

Gassenfräsen / Slot milling /
Fresatura di cave

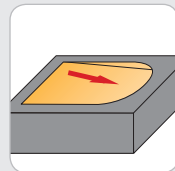

Rampe eintauchen / Ramping /
Fresatura in rampa

Trägerwerkzeuge / Holders / Corpi fresa



3

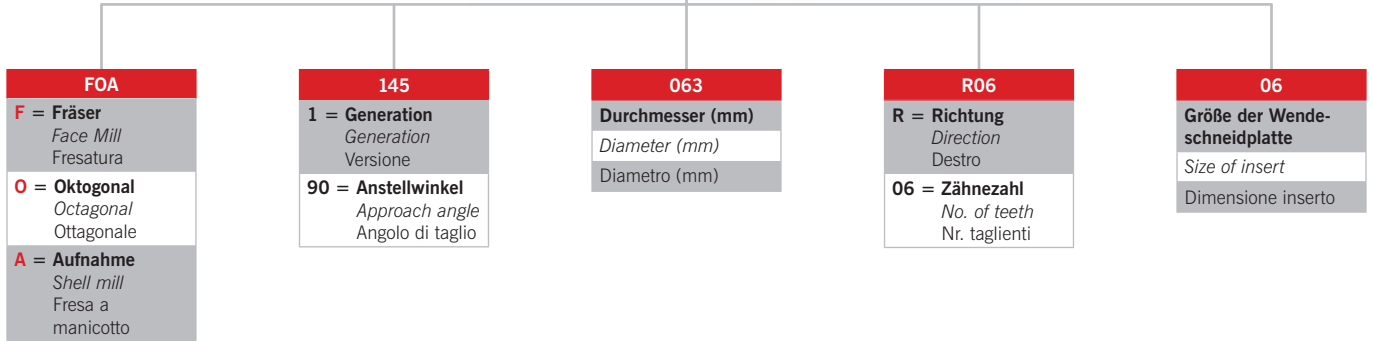

Wendeschneidplatten / Indexable Inserts / Inserti

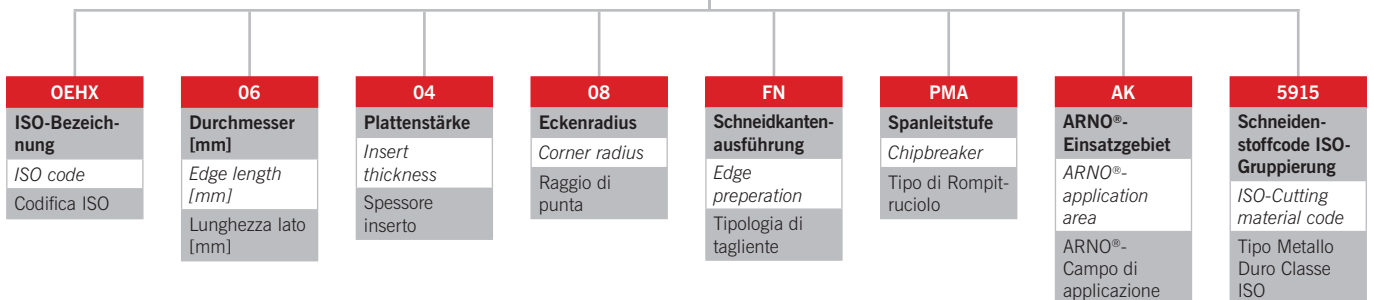



Trägerwerkzeuge – mit Okto-WSP

Holders using octagonal inserts

Corpi con inserto ottagonale

Seite/Page/Pagina **92**



Trägerwerkzeuge – mit Rund-WSP

Holders using round inserts

Corpi con inserto tondo

Seite/Page/Pagina **93**



Wendeschneidplatten

Okto-WSP

Octagonal Inserts

Inserti ottagonali

Seite/Page/Pagina **96**



Wendeschneidplatten

Rund-WSP

Round Inserts

Inserti tondi

Seite/Page/Pagina **96**

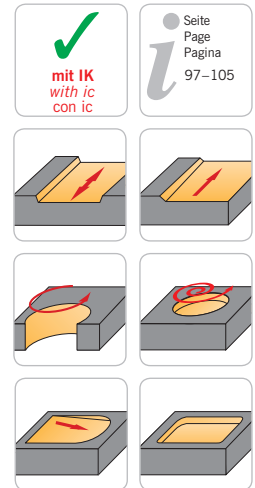
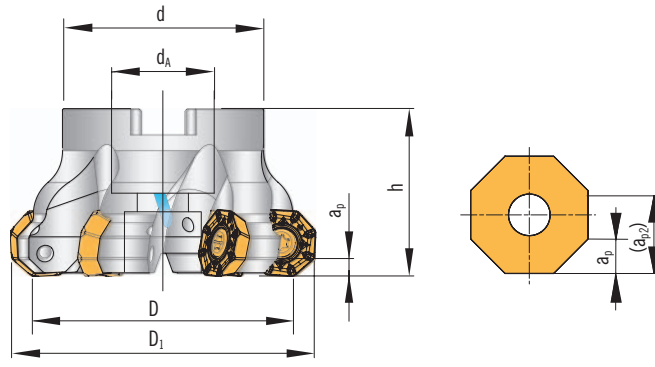

Planfräser mit Okto-WSP / Face milling cutter with octagonal inserts /
 Frese per spianatura inserti ottagonale

3

Bezeichnung Designation Articolo	D	D ₁	d _A	h	d	a _p	(a _{p2})	z	Wendeschneidplatte Indexable insert Inserito
FOA-145.040.R04-06	40	50	16	40	35	4	(10)	4	SD.. 10...
FOA-145.042.R05-06	42	52	16	40	40	4	(10)	5	SD.. 10...
FOA-145.050.R05-06	50	60	22	40	48	4	(10)	5	SD.. 10...
FOA-145.052.R06-06	52	62	22	40	48	4	(10)	6	SD.. 10...
FOA-145.056.R06-06	56	66	27	50	60	4	(10)	6	SD.. 10...
FOA-145.063.R05-06	63	73	27	50	60	4	(10)	5	SD.. 10...
FOA-145.063.R06-06	63	73	22	40	48	4	(10)	6	SD.. 10...
FOA-145.066.R06-06	66	76	27	50	60	4	(10)	6	SD.. 10...
FOA-145.075.R07-06	75	85	27	50	60	4	(10)	7	SD.. 10...
FOA-145.080.R07-06	80	90	27	50	60	4	(10)	7	SD.. 10...
FOA-145.085.R07-06	85	95	27	50	60	4	(10)	7	SD.. 10...
FOA-145.100.R10-06	100	110	32	50	78	4	(10)	10	SD.. 10...
FOA-145.125.R11-06	125	135	40	60	90	4	(10)	11	SD.. 10...
FOA-145.160.R13-06*	160	170	40	60	104	4	(10)	13	SD.. 10...
FOA-145.250.R16-06*	250	260	60	60	194	4	(10)	16	SD.. 10...

* ohne Innenkühlung
 * without internal coolant
 * senza adduzione interna

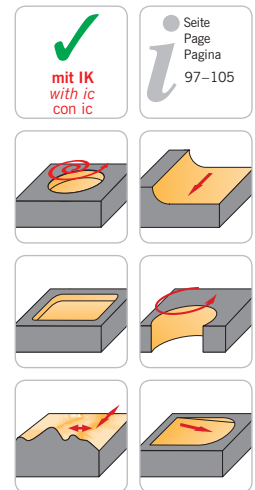
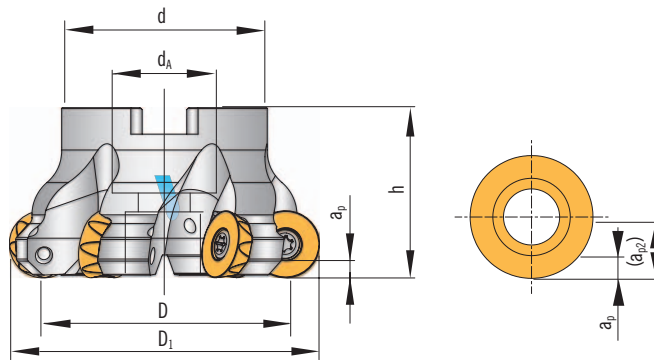

Planfräser mit Rund-WSP / Face milling cutter with round inserts /
 Frese per spianatura inserti tondo

Bezeichnung Designation Articolo	D	D _i	d _A	h	d	a _p	(a _{p2})	z	Wendeschneidplatte Indexable insert Inserto
FOA-145.040.R04-06	34	49,8	16	35	40	< 2,3	< 8	4	RO.. 1604...
FOA-145.042.R05-06	36	51,8	16	40	40	< 2,3	< 8	5	RO.. 1604...
FOA-145.050.R05-06	44	59,8	22	48	40	< 2,3	< 8	5	RO.. 1604...
FOA-145.052.R06-06	46	61,8	22	48	40	< 2,3	< 8	6	RO.. 1604...
FOA-145.056.R06-06	50	65,8	27	60	40	< 2,3	< 8	6	RO.. 1604...
FOA-145.063.R05-06	57	72,8	27	60	50	< 2,3	< 8	6	RO.. 1604...
FOA-145.063.R06-06	57	72,8	22	48	40	< 2,3	< 8	6	RO.. 1604...
FOA-145.066.R06-06	60	75,8	27	60	50	< 2,3	< 8	6	RO.. 1604...
FOA-145.075.R07-06	69	84,8	27	60	50	< 2,3	< 8	7	RO.. 1604...
FOA-145.080.R07-06	74	89,8	27	60	50	< 2,3	< 8	7	RO.. 1604...
FOA-145.085.R07-06	79	94,8	27	60	50	< 2,3	< 8	7	RO.. 1604...
FOA-145.100.R10-06	94	109,8	32	78	50	< 2,3	< 8	10	RO.. 1604...
FOA-145.125.R11-06	119	134,8	40	90	60	< 2,3	< 8	11	RO.. 1604...
FOA-145.160.R13-06*	154	169,8	40	104	60	< 2,3	< 8	13	RO.. 1604...
FOA-145.250.R16-06*	244	259,8	194	60	60	< 2,3	< 8	16	RO.. 1604...

* ohne Innenkühlung
 * without internal coolant
 * senza adduzione interna



3

- PMA

Für die Zerspantung von Aluminium und NE-Metallen.



- PMA

For machining aluminium, aluminium alloys and non-ferrous materials.

Schlicht- bis Schrupperzspanung

Finishing to roughing
Finitura e sgrassatura

einseitig
single sided
singolo lato



- PMA

Per la lavorazione di alluminio e materiali non ferrosi.

- PMG

Geometrie für die Zerspantung von Gusswerkstoffen.



- PMG

Geometry for machining cast materials.

Mittlere bis grobe Zerspantung

Medium to rough cutting
Sgrassatura da media a pesante

einseitig
single sided
singolo lato



- PMG

Geometria per la lavorazione di ghisa.

- PMR

Zur Bearbeitung rostfreier Stähle.



- PMR

For machining stainless steels.

Mittlere bis grobe Zerspantung

Medium to rough cutting
Sgrassatura da media a pesante

einseitig
single sided
singolo lato



- PMR

Per la lavorazione di acciaio inox.

- PMS

Geometrie für die Stahlbearbeitung.



- PMS

Geometry for machining steel.

Mittlere bis grobe Zerspantung

Medium to rough cutting
Sgrassatura da media a pesante

einseitig
single sided
singolo lato

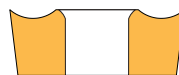

- PMS

Geometria per la lavorazione dell'acciaio.

Hartmetall beschichtet / Carbide grade coated / Metallo duro rivestito**AK5915**

Neuste Schichtgeneration auf Basis einer CVD-AlTiN Schicht.

Auf Grund der großen Härte können erheblich höhere V_c -Werte gefahren werden.

Newest coating technology based upon CVD-AlTiN coating.

Due to the increased hardness it is possible to operate at increased cutting speed.

Innovativa tecnologia di rivestimenti su base CVD-TiAlN.

Per lavorazioni ad elevate velocità di taglio.

AM5740

PVD-beschichtete Hartmetallsorte mit einer AlTiN-Mehrlagenbeschichtung.

Allroundsorte für die moderne Bearbeitung, die eine gute Ausgewogenheit in Bezug auf die Bearbeitungssicherheit und Produktivität bietet.

PVD coated (AlTiN multilayer) carbide insert. For milling stainless steel at medium to high cutting speeds, also suitable for milling high temperature alloys and titanium alloys.

Inserto con rivestimento multistrato (AlTiN) PVD. Per la fresatura di acciaio inossidabile a velocità di taglio da medie ad alte, adatto anche per la fresatura di leghe resistenti al calore o leghe di titanio.

AP2130

CVD-beschichtete Hartmetallsorte. Optimiert für beste Produktivität beim Fräsen von Stahl. Besonders geeignet zur wirtschaftlichen Trockenbearbeitung. Hohe Bearbeitungssicherheit kombiniert mit guter Verschleißfestigkeit zeichnet diese Sorte aus.

PVD-coated carbide grade. Suitable for finishing steel, stainless steel and cast materials. A very universal grade with high heat and oxidation resistance.

Qualità di Metallo duro Rivestita CVD. Ideale per la lavorazione di acciai. Particolarmente adatto per lavorazioni a secco. Buona affidabilità data dal compromesso tra tenacità e resistenza all'usura.

AP5230

PVD-beschichtete Hartmetallsorte. Geeignet zum Schlichten von Stählen, rostfreien Stählen und Gusswerkstoffen. Eine sehr universell einsetzbare Sorte mit hoher Hitze- und Oxidationsbeständigkeit.

PVD-coated carbide grade. Suitable for finishing steel, stainless steel and cast materials. A very universal grade with high heat and oxidation resistance.

Qualità di metallo duro con rivestimento PVD. Adatto per la finitura di acciai, acciai inossidabili e Ghisa. Un grado universale molto versatile ad alte temperature e per leghe resistenti all'ossidazione.

Hartmetall unbeschichtet / Carbide grade uncoated / Metallo duro non rivestito**AN1015**

Unbeschichtete Hartmetallsorte zum Schlichten und Schruppen von Aluminiumlegierungen und NE-Metallen.

Geschliffene Schneidkanten. Zur Reduzierung der Aufbauschneidenbildung ist die Spanfläche hochglanzpoliert.

Uncoated carbide grade for roughing and finishing of aluminium alloys and with its sharp edge also for non-ferrous materials. Insert is polished to reduce build up edge.

Qualità di metallo duro non rivestita. Per la finitura e la sgrassatura di leghe non ferrose e di alluminio.

Okto-WSP / Octagonal Inserts / Inserto ottagonale

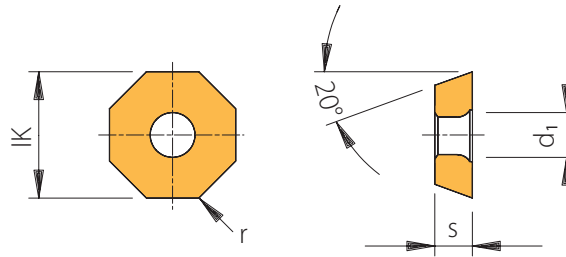

Bezeichnung Designation Articolo	IK	s	d ₁	r	beschichtet coated rivestito				unbeschichtet uncoated non rivestito
					AK5915	AM5740	AP2130	AP5230	AN1015
OEHX 060408FN-PMA	16	4,5	5,5	0,8					●
OEMX 060408ZZN-PMG	16	4,5	5,5	0,8	●				
OEMX 060408ZZN-PMR	16	4,5	5,5	0,8		●			
OEMX 060408ZZN-PMS	16	4,5	5,5	0,8			●		
OEHX 0604ZZ	16	4,5	5,5	400				●	

- **Hauptanwendung**
Main application
Applicazione principale
- **Nebenanwendung**
Secondary application
Applicazione secondaria

P			●	●
M		●		○
K	●			○
N				●
S		○		
H				

Rund-WSP / Round Inserts / Inserto tondo

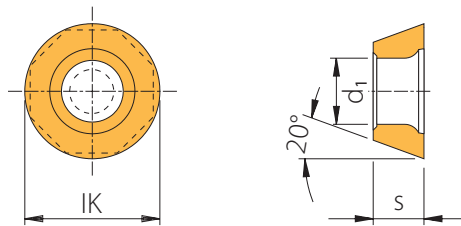

Bezeichnung Designation Articolo	IK	s	d ₁	beschichtet coated rivestito			unbeschichtet uncoated non rivestito
				AK5915	AM5740	AP2130	AN1015
ROHX 1604MOEN-PMA	16	4,6	5,5				●
ROMX 1604MOEN-PMG	16	4,6	5,5	●			
ROMX 1604MOSN-PMR	16	4,6	5,5		●		
ROMX 1604MOSN-PMS	16	4,6	5,5			●	

- **Hauptanwendung**
Main application
Applicazione principale
- **Nebenanwendung**
Secondary application
Applicazione secondaria

P			●	
M		●		
K	●			
N				●
S		○		
H				

Schrauben und Schraubendreher

Screws and Screwdrivers

Chiavi e Viti

Bezeichnung Designation Articolo	Drehmoment Torque Forza di serraggio	TorxPlus®-Spanschraube TorxPlus®-Screw TorxPlus®-Vite	TorxPlus®-Schlüssel TorxPlus®-Key TorxPlus®-Chiave
FOA-145....	5 Nm	AS 0046	T5120-IP

3

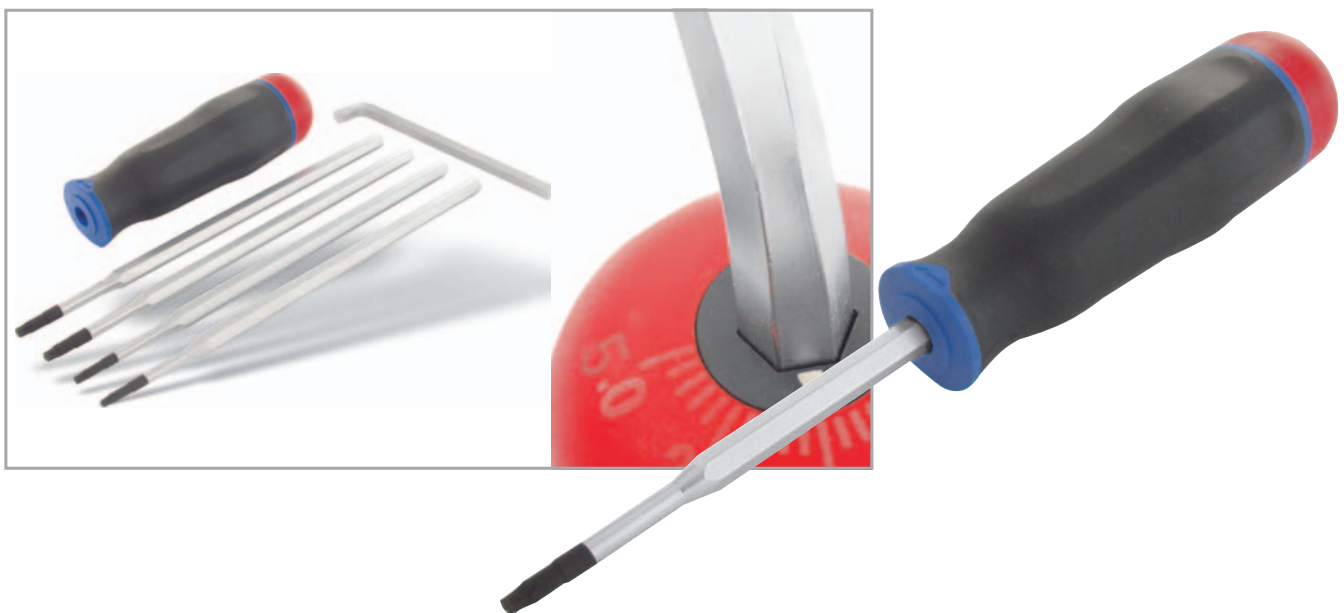
**Hinweis: Drehmoment-Schraubendreher siehe Seite 289. Unsere Empfehlung: Das Set Drehmoment 3.**

Remark: For torque screwdrivers see page 289. OUR Recommendation: Torque Set 3.

Nota: Chiavi dinamometriche a pagina 289. Suggestimento: Torque Set 3.

ROC-Mill – Schnittdatenrichtwerte Planfräser mit WSP OE...06... und RO...16...

3

ISO	Werkstoff		Brinell-Härte HB	Schnittgeschwindigkeit V _c [m/min]				
				AP2130	AP5230	AM5740	AK5915	AN1015
P	Unlegierter Stahl und Stahlguss	< 0,15% C / vergütet	125	210-350	200-280			
		0,15-0,45% C / vergütet	150-250	170-320	170-260			
		> 0,45% C / vergütet	300	150-280	170-250			
	Niedrig legierter Stahl und Stahlguss	geglüht	180	150-250	150-250			
		vergütet	250-300	140-210	150-250			
		vergütet	350	100-180	150-250			
	Hochlegierter Stahl, hochlegierter Werkzeugstahl und Stahlguss	geglüht	200	140-210	150-230			
vergütet		350	80-170	150-230				
martensitisch, vergütet		325	100-170	150-230				
M	Nichtrostender Stahl	ferritisch, martensitisch, geglüht	200	90-200	150-230	110-240		
		austenitisch, abgeschreckt	180	90-150	150-230	85-170		
		Duplex, abgeschreckt	230	70-180	150-230	80-210		
		martensitisch/austenitisch, abgeschreckt	330	70-140	150-230	80-160		
K	Grauguss	perlitisches/ferritisches	180				230-400	
		perlitisches/martensitisches	260				180-320	
	Gusseisen mit Kugelgraphit	ferritisches	160				200-310	
		perlitisches	-					
Temperguss	ferritisches	130				170-240		
	perlitisches	230				150-220		
N	Aluminium-Knetlegierungen	nicht aushärtbar	60				< 2000	
		aushärtbar, ausgehärtet	100				< 2000	
	Aluminium-Gusslegierungen	≤ 12% Si, ausgehärtet	80				600-780	
		≤ 12% Si, aushärtbar, ausgehärtet	90				530-600	
		≤ 12% Si, nicht aushärtbar	130				290-350	
	Kupfer und Kupferlegierungen (Bronze/Messing)	Automatenlegierung, Pb > 1%	-				460	
		Messing, Rotguss	-				310	
Aluminiumbronze		90				200-250		
Kupfer und Elektrolytkupfer		100				200-300		
Nichtmetallische Werkstoffe	Duroplaste	100						
	Faserverstärkte Kunststoffe	-						
	Hartgummi	-						
S	Warmfeste Legierungen	Fe-Basis, geglüht	200			60-75		
		Fe-Basis, ausgehärtet	280			60-65		
		Ni- oder Co-Basis, geglüht	250			60-70		
		Ni- oder Co-Basis 30-58 HRC, gegossen	-			40-60		
		Ni- oder Co-Basis 1500-2200 Nmm ² , ausgehärtet	-					
Titanlegierungen, Alpha+Beta-Legierungen	Rein-Titan	Rm 440			60-75			
	ausgehärtet	Rm 1050			45-60			
H	Gehärteter Stahl	gehärtet und angelassen	55 HRC					
		gehärtet und angelassen	60 HRC					
	Hartguss	gegossen	400					
Gehärtetes Gusseisen	gehärtet und angelassen	55 HRC						

Die Tabellenwerte sind Richtwerte. Es kann notwendig sein, die Werte den jeweiligen Bearbeitungsumständen anzupassen.

ROC-Mill – Cutting data recommendation for inserts OE...06... and RO...16...

ISO	Material	Brinell-Hardness HB	Cutting speed V _c [m/min]				
			AP2130	AP5230	AM5740	AK5915	AN1015
P	Unalloyed steel and cast steel	< 0,15% C / hardened and tempered	125	210-350	200-280		
		0,15-0,45% C / hardened and tempered	150-250	170-320	170-260		
		> 0,45% C / hardened and tempered	300	150-280	170-250		
	Low alloyed steel and cast steel	annealed	180	150-250	150-250		
		hardened and tempered	250-300	140-210	150-250		
		hardened and tempered	350	100-180	150-250		
	High alloyed steel, high alloyed tool Steel and cast steel	annealed	200	140-210	150-230		
		hardened and tempered	350	80-170	150-230		
Stainless steel	ferritic, annealed	200	140-190	150-230			
Cast steel	martensitic, hardened and tempered	325	100-170	150-230			
M	Stainless steel	ferritic, martensitic annealed	200	90-200	150-230	110-240	
		austenitic, chilled	180	90-150	150-230	85-170	
		Duplex, chilled	230	70-180	150-230	80-210	
		martensitic/austenitic, chilled	330	70-140	150-230	80-160	
K	Cast iron	pearlitic/ferritic	180				230-400
		pearlitic/martensitic	260				180-320
	Cast iron with nodular graphite	ferritic	160				200-310
		pearlitic	-				
Malleable cast iron	ferritic	130				170-240	
	pearlitic	230				150-220	
N	Aluminium alloys. long chipping	not heat treatable	60				< 2000
		heat treatable, heat treated	100				< 2000
	Casted aluminium alloys	≤ 12% Si, heat treated	80				600-780
		≤ 12% Si, heat treatable, heat treated	90				530-600
		≤ 12% Si, not heat treatable	130				290-350
	Copper and copper alloys, (Brass/Bronze)	Lead alloys, Pb > 1%	-				460
		Brass, Bronze	-				310
		Aluminium bronze	90				200-250
Copper and elektrolyte copper		100				200-300	
Non ferrous materials	Duroplastic	100					
	Re-inforced plastics	-					
	Hard rubber	-					
S	High temperature resistant alloys	Fe-alloyed, annealed	200			60-75	
		Fe-alloyed, heat treated	280			60-65	
		Ni- or Co-alloyed, annealed	250			60-70	
		Ni- or Co-alloyed 30-58 HRC, casting	-			40-60	
		Ni- or Co-alloyed 1500-2200 Nmm ² , heat treated	-				
Titanium alloys Alpha- and Beta-alloys	Pure titan	Rm 440			60-75		
	heat treated	Rm 1050			45-60		
H	Hardened steel	hardened and tempered	55 HRC				
		hardened and tempered	60 HRC				
	Hard cast iron	casting	400				
Hardened cast iron	hardened and tempered	55 HRC					

The data given is only approximate values. It can be necessary to adjust this data to the individual machining operation.



ROC-Mill – Suggerimenti tecnici inserto ottagonale OE...06... e tondo RO...16...

ISO	Materiale	Durezza Brinnell HB	Velocità di taglio V _c [m/min]				
			AP2130	AP5230	AM5740	AK5915	AN1015
P	Acciai non legati	< 0,15 % C / bonificato	125	210-350	200-280		
		0,15-0,45 % C / bonificato	150-250	170-320	170-260		
		> 0,45 % C / bonificato	300	150-280	170-250		
	Acciai debolmente legati e Ghise acciaiose	ricotto	180	150-250	150-250		
		bonificato	250-300	140-210	150-250		
		bonificato	350	100-180	150-250		
	Acciai fortemente legati	ricotto	200	140-210	150-230		
Acciai da costruzione e Ghise acciaiose	bonificato	350	80-170	150-230			
Acciai inossidabili	ferritico, ricotto	200	140-190	150-230			
Ghisa acciaiosa	martensitico, bonificato	325	100-170	150-230			
M	Acciai inossidabili	ferritico, martensitico ricotto	200	90-200	150-230	110-240	
		austenitico, temprato	180	90-150	150-230	85-170	
		Duplex, temprato	230	70-180	150-230	80-210	
		martensitico/austenitico, temprato	330	70-140	150-230	80-160	
K	Ghisa grigia	perlitica/ferritico	180				230-400
		perlitica/martensitico	260				180-320
	Ghisa sferoidale	ferritico	160				200-310
Ghisa temprata	ferritico	130				170-240	
	perlitica	230				150-220	
N	Leghe di Alluminio stampato	non invecchiato	60				< 2000
		aushärtbar, invecchiato	100				< 2000
	Leghe di Alluminio da fusione	≤ 12 % Si, invecchiato	80				600-780
		≤ 12 % Si, aushärtbar, invecchiato	90				530-600
		≤ 12 % Si, non invecchiato	130				290-350
	Rame e Leghe di Rame (Bronzo/Ottone)	Automatici, Pb > 1%	-				460
Ottone, Bronzo		-				310	
Bronzoalluminio		90				200-250	
Rame e Rame Elettrolitico		100				200-300	
Materiali non metallici	Duroplastiche	100					
	Plastiche rinforzate	-					
	Gomme dure	-					
S	Leghe resistenti al calore	Base-Fe, ricotto	200		60-75		
		Base-Fe, invecchiato	280		60-65		
		Base Ni o Co, ricotto	250		60-70		
		Base Ni o Co 30-58 HRC, da fusione	-		40-60		
		Base Ni o Co 1500-2200 Nmm ² , invecchiato	-				
Leghe di Titanio, Leghe Alpha+Beta	Titanio puro	Rm 440		60-75			
	invecchiato	Rm 1050		45-60			
H	Acciaio Temprato	temprato e rinvenuto	55 HRC				
		temprato e rinvenuto	60 HRC				
	Ghisa Temprata	temprato e rinvenuto	55 HRC				

Dati indicativi. Può essere necessario adattarli alle singole applicazioni.

Wendeschneidplatte Okto-WSP – Schnittdatenrichtwerte

Octagonal indexable inserts – Cutting data recommendation

Inserto ottagonale – Parametri di taglio consigliati

	ISO	Werkstoff / Material / Materiale	Planfräsen / Face milling / Spianatura		
			v_c [m/min]	f_z [mm]	a_p [mm]
OE...0604...	P	Stahl / Steel / Acciaio	150–350	0,12–0,35	< 4
	M	Rostfreier Stahl / Stainless steel / Acciaio inossidabile	130–240	0,1–0,3	< 4
	K	Guss / Cast iron / Ghisa	150–400	0,15–0,4	< 4
	N	NE-Metalle / Non ferrous materials / Materiali non ferrosi	<2000	0,1–0,15	< 4
	S	Hochwarmfest / High temperature resistant alloys / Leghe resistenti al calore	25–75	0,1–0,25	< 4

Wendeschneidplatte Rund-WSP – Schnittdatenrichtwerte

Round indexable inserts – Cutting data recommendation

Inserto tondo – Parametri di taglio consigliati

	ISO	Werkstoff / Material / Materiale	Mittlere Bearbeitung Medium machining Media asportazione			Schrupp-Bearbeitung Rough machining Sgrossatura		
			v_c [m/min]	f_z [mm]	a_p [mm]	v_c [m/min]	f_z [mm]	a_p [mm]
			RO...1604...	P	Stahl / Steel / Acciaio	150–350	0,3–0,9	< 2,3
M	Rostfreier Stahl / Stainless steel / Acciaio inossidabile	130–240		0,2–0,6	< 2,3	60–150	0,2–0,4	< 4
K	Guss / Cast iron / Ghisa	150–400		0,2–0,5	< 2,3	150–260	0,2–0,4	< 4
S	Hochwarmfest / High temperature resistant alloys / Leghe resistenti al calore	30–75		0,15–0,4	< 2,3	30–75	0,15–0,3	< 3

Die Tabellenwerte sind Richtwerte. Es kann notwendig sein, die Werte den jeweiligen Bearbeitungsumständen anzupassen.

The data given is only approximate values. It can be necessary to adjust this data to the individual machining operation.

Dati indicativi. Può essere necessario adattarli alle singole applicazioni.



3

ISO	Hartmetall beschichtet <i>Carbide coated</i> Metallo duro rivestito	Hartmetall unbeschichtet <i>Carbide uncoated</i> Metallo duro non rivestito PKD/CBN/CERMET	Schneidstoff <i>Cutting material</i> Materiale da taglio	Anwendung <i>Application</i> Parametri			
P Stahl, Stahlguss, langspanender Temperguss <i>Steel, cast steel, long chipping malleable iron</i> Acciaio colato, ghisa temprata a truciolo lungo	10						
	20						
	30	AP2130		Zähigkeit <i>Toughness</i> Tenacità	Verschleißbeständigkeit <i>Resistance to wear</i> Resistenza all'usura	Vorschub <i>Feed rate</i> Avanzamento	Schnittgeschwindigkeit <i>Cutting speed</i> Velocità di taglio
	40	AP5230					
M Rostfreier Stahl, Stahlguss, Manganstahl, Automatenstahl <i>Stainless steel, cast steel, manganese steel, free cutting steel</i> Acciaio inossidabile, acciaio colato, acciaio al manganese, ghisa legata, ghisa temprata, acciaio automatico, leghe refrattarie	10						
	20						
	30	AP5230		Zähigkeit <i>Toughness</i> Tenacità	Verschleißbeständigkeit <i>Resistance to wear</i> Resistenza all'usura	Vorschub <i>Feed rate</i> Avanzamento	Schnittgeschwindigkeit <i>Cutting speed</i> Velocità di taglio
	40		AM5740				
K Grauguss, Kokillenhartguss, kurzspanender Temperguss <i>Grey cast iron, chilled hard cast iron, short chipping malleable iron</i> Ghisa grigia, ghisa fusa in conchiglia, ghisa temprata a truciolo corto, acciaio temprato, metalli non ferrosi, plastica, legno	10						
	20	AK6915					
	30		AP5230	Zähigkeit <i>Toughness</i> Tenacità	Verschleißbeständigkeit <i>Resistance to wear</i> Resistenza all'usura	Vorschub <i>Feed rate</i> Avanzamento	Schnittgeschwindigkeit <i>Cutting speed</i> Velocità di taglio
	40						
N Aluminium und Al-Legierungen, nichtmetallische Werkstoffe <i>Aluminium and Al-alloys, non ferrous materials</i> Alluminio e leghe di alluminio, materiali non metallici	10		AN1015				
	20			Zähigkeit <i>Toughness</i> Tenacità	Verschleißbeständigkeit <i>Resistance to wear</i> Resistenza all'usura	Vorschub <i>Feed rate</i> Avanzamento	Schnittgeschwindigkeit <i>Cutting speed</i> Velocità di taglio
	30						
	40						
S Warmfeste Legierungen, Titanlegierungen <i>High temperature resistant alloys, Titanium alloys</i> Leghe refrattarie, leghe di titanio	10						
	20						
	30		AM5740	Zähigkeit <i>Toughness</i> Tenacità	Verschleißbeständigkeit <i>Resistance to wear</i> Resistenza all'usura	Vorschub <i>Feed rate</i> Avanzamento	Schnittgeschwindigkeit <i>Cutting speed</i> Velocità di taglio
	40						
H Gehärteter Stahl, Hartguss <i>Hardened Steel, hard cast iron</i> Acciaio temprato, ghisa conchigliata	10						
	20			Zähigkeit <i>Toughness</i> Tenacità	Verschleißbeständigkeit <i>Resistance to wear</i> Resistenza all'usura	Vorschub <i>Feed rate</i> Avanzamento	Schnittgeschwindigkeit <i>Cutting speed</i> Velocità di taglio
	30						
	40						

Hauptanwendungsbereich / Main application area / Applicazione principale



Nebenanwendungsbereich / Secondary application area / Applicazione secondaria

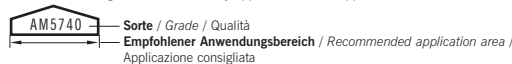

Montage der Wendeschneidplatte

Fitting of indexable insert

Montaggio dell'inserto

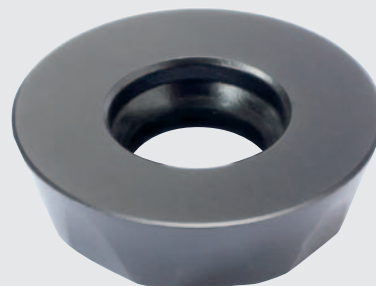
• **Fräswerkzeug in Montageplatz einspannen***Fit holder into tool block**Montare il corpo fresa nel relativo blocco*• **Spanschraube lösen***Unlock screws**Svitare le viti*• **Plattensitz reinigen***Clean insert pocket**Pulire la sede inserto*• **Spanschraube leicht anlegen***Prepare new insert screw**Preparare la nuova vite*• **Die radiale und axiale Anlagefläche mit Fingerdruck im Plattensitz vermitteln***Position the indexable insert in the insert pocket**Posizionare l'inserto nella sede*• **Spanschraube bei angedrückter WSP mit voreingestelltem (5 Nm) Drehmomentschlüssel spannen***Using the pre-set torque key, fasten the screw**to the recommended torque setting of 5Nm**Utilizzando la chiave dinamometrica, serrare la vite con momento torcente 5Nm***UNSERE EMPFEHLUNG: Das Set Drehmoment 3.***OUR RECOMMENDATION: Torque Set 3.**SUGGERIMENTO: Torque Set 3***WSP RO...1604... mit Anlageflächen***Insert WSP RO...1604...**Inserto tondo RO...1604...*

3

Einsatzdaten Okto-WSP OE...06...

Cutting data indexable inserts OE...06... octagonal inserts
Parametri di taglio suggeriti con inserti ottagonali OE...06...

Zirkulares Eintauchen / Helical interpolation / Fresatura circolare

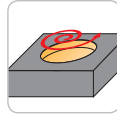
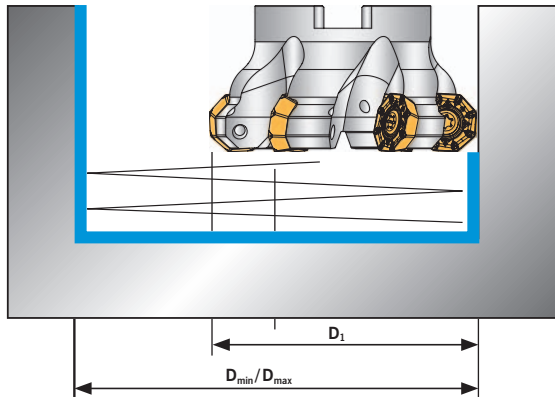

Fräser Cutter Fresatura	D ₁	D _{min}	D _{max}
FOA-145.040	50	77	90
FOA-145.050	60	97	110
FOA-145.063	73	123	136
FOA-145.080	90	157	170
FOA-145.100	110	197	210
FOA-145.125	135	247	260
FOA-145.160	170	317	330

D_{min} = kleinster Bohrungsdurchmesser
minimum bore diameter
diametro minimo di foro

D_{max} = größter Bohrungsdurchmesser für eben Bodenflächen
maximum bore diameter for flat area
diametro massimo foro per parte piana

3

Axiales Eintauchen / Plunge milling / Fresatura assiale

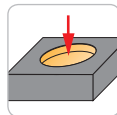
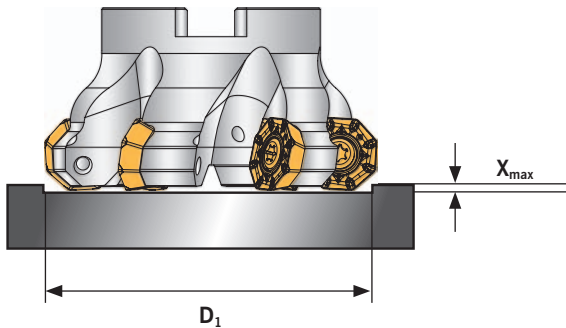

D ₁	X _{max}
FOA-145.....	5,5

Schräges Eintauchen / Ramping / Fresatura in rampa

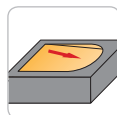
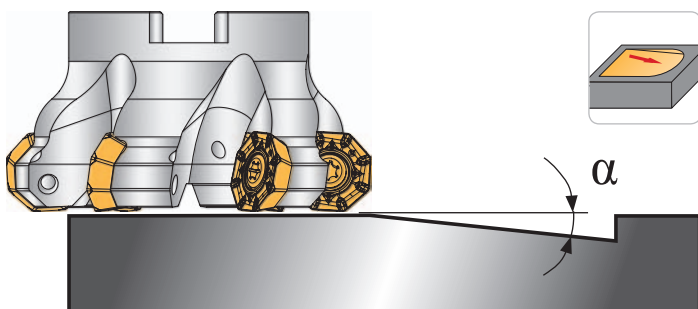

Fräser Cutter Fresatura	α	Mindest-Verfahrweg Minimum travel Corsa minima
FOA-145.040	10,7	29 mm
FOA-145.050	8,7	36 mm
FOA-145.063	6,0	52 mm
FOA-145.080	4,5	69 mm
FOA-145.100	3,5	89 mm
FOA-145.125	2,7	114 mm
FOA-145.160	2,1	149 mm

Einsatzdaten Rund-WSP RO...16...

Cutting data RO...16... round indexable inserts

Parametri di taglio suggeriti con inserti tondo RO...16...

Zirkulares Eintauchen / Helical interpolation / Fresatura circolare

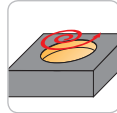
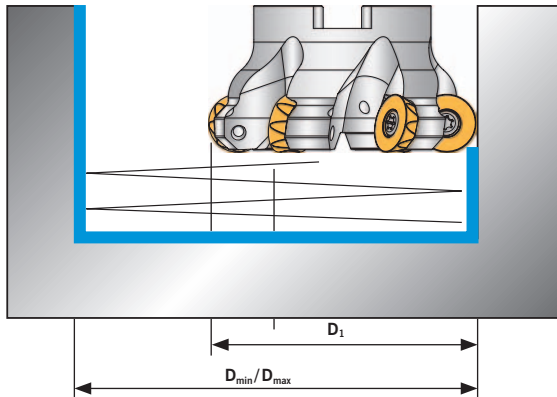

Fräser Cutter Fresatura	D ₁	D _{min}	D _{max}
FOA-145.040	49,8	68	99
FOA-145.050	59,8	88	119
FOA-145.063	72,8	114	145
FOA-145.080	89,8	148	179
FOA-145.100	109,8	188	219
FOA-145.125	134,8	238	269
FOA-145.160	169,8	308	339

D_{min} = kleinster Bohrungsdurchmesser
minimum bore diameter
diametro minimo di foro

D_{max} = größter Bohrungsdurchmesser für eben Bodenflächen
maximum bore diameter for flat area
diametro massimo foro per parte piana



Axiales Eintauchen / Plunge milling / Fresatura assiale

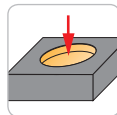
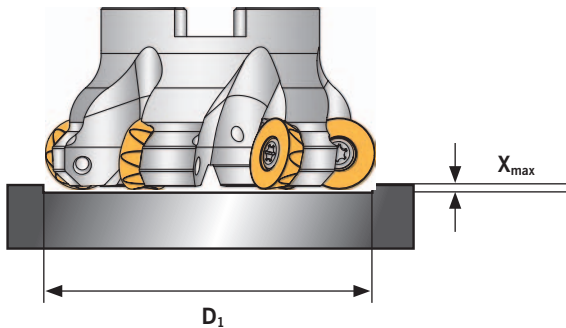

D ₁	X _{max}
FOA-145.....	5,5

Schräges Eintauchen / Ramping / Fresatura in rampa

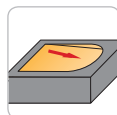
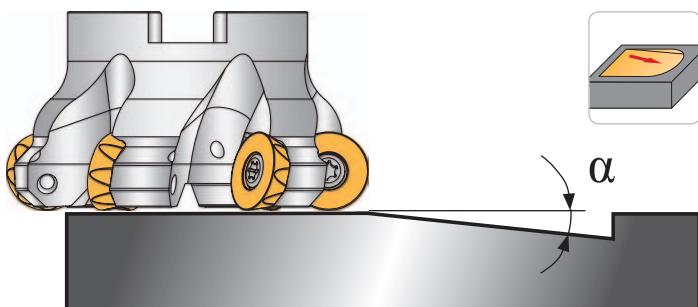

Fräser Cutter Fresatura	α	Mindest-Verfahrweg Minimum travel Corsa minima
FOA-145.040	14,3	19,8 mm
FOA-145.050	8,0	36,0 mm
FOA-145.063	6,7	42,8 mm
FOA-145.080	4,8	59,8 mm
FOA-145.100	3,6	79,8 mm
FOA-145.125	2,7	104,8 mm
FOA-145.160	2,0	139,8 mm

Schnell, flexibel und individuell.

Quick, flexible and individual.

Veloce, flessibile e individuale.

- **Wir bieten Ihnen Sonderlösungen für Ihre individuellen Bedürfnisse.**
 - **Bestellen Sie bis 18 Uhr unsere Produkte, erhalten Sie Ihre Lieferung bereits am nächsten Tag.**
 - **Da wir Konstruktion, Produktion und Vertrieb unter einem Dach vereinen, können wir eine hohe Qualität unserer Produkte garantieren.**
 - **Die Mitarbeiter unseres Außendienstes besuchen Sie regelmäßig und unterstützen Sie mit ihrem Produktwissen.**
 - **Unsere Anwendungstechniker beraten Sie direkt vor Ort in Ihrem Werk.**
 - **Die kompetenten ARNO-Ansprechpartner stehen Ihnen bei Fragen und Anliegen gerne zur Verfügung – weltweit.**
- *We offer special solutions for your individual requirement.*
 - *Order your products by 15.30 CET for same day dispatch.*
 - *As we design, manufacture, and service our own products, we offer you only top quality products.*
 - *Our external sales engineers will be visiting regularly.*
 - *Our trained engineers are experienced and will be able to help you with most applications.*
 - *Our competent global ARNO-partners are always available to answer any questions you may have.*
- Offriamo soluzioni speciali per le vostre esigenze.
 - Ordinate i nostri prodotti entro le 15,30 e li avrete il giorno dopo.
 - Possiamo offrirvi la massima qualità avendo produzione, progettazione e vendita in un unico posto.
 - Verete visitati regolarmente dai nostri collaboratori.
 - I nostri tecnici sapranno consigliarvi per il meglio.
 - Tutto il team ARNO è a vostra completa disposizione.



Weitere Informationen finden Sie unter:

For more information see:

Altre informazioni sotto:

www.arno.de

ARNO® ISO-Frässysteme

- Übersicht
- Fräswerkzeuge
 - Ersatzteile
- Schnittwerte
- Anwendungshinweise

ARNO® ISO-milling systems

- *Program Overview*
- *Milling cutters*
 - *Spare parts*
- *Cutting data*
- *Application reference*

ARNO®-Sistema di fresatura ISO

- Gamma prodotti **108 – 113**
- Frese **114 – 154**
 - Attacchi **177**
- Parametri di taglio **156 – 165**
- Suggerimenti tecnici **166 – 176**

4

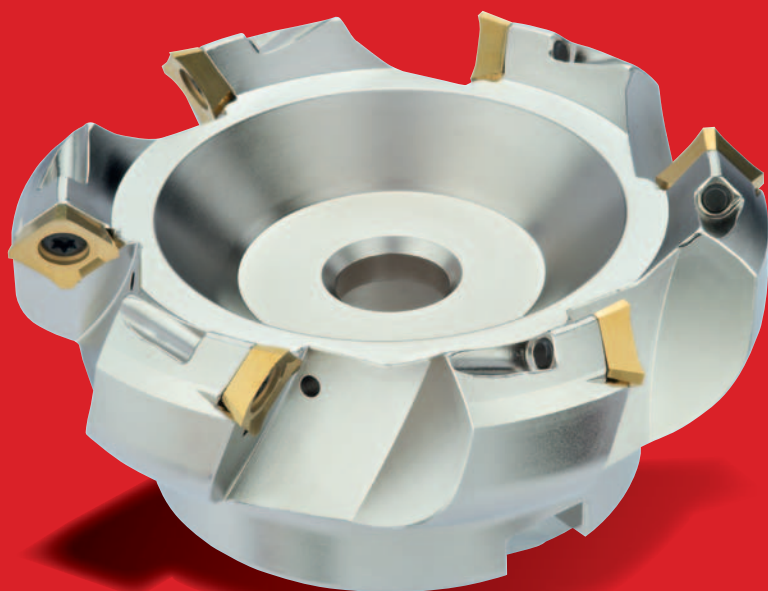

4

Eckfräser

Square shoulder
roughing cutter
Frese a riccio per
spallamenti retti

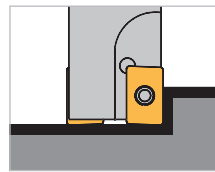

90ES. ..P10

**Schaftfräser mit
Innenkühlung**
End mill with
internal coolant supply
Frese con passaggio
refrigerante interno

Seite
Page
Pagina **114**

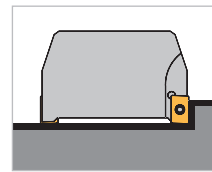

90EA. ..P10

**Aufsteckfräser mit
Innenkühlung**
Shell type milling cutter
with internal cooling
Frese con passaggio
refrigerante interno

Seite
Page
Pagina **115**

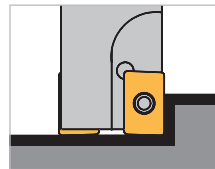

90ES. ..P16

**Schaftfräser mit
Innenkühlung**
End mill with
internal coolant supply
Frese con passaggio
refrigerante interno

Seite
Page
Pagina **116**

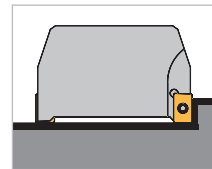

90EA. ..P16

**Aufsteckfräser mit
Innenkühlung**
Shell type milling cutter
with internal cooling
Frese con passaggio
refrigerante interno

Seite
Page
Pagina **117**

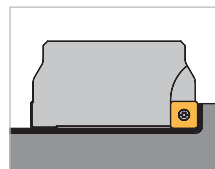

90EA. ..D12

**Plan-Eckfräser mit
Innenkühlung**
Square shoulder milling cutter
with internal coolant supply
Frese per spianatura –
spallamenti con passaggio
refrigerante interno

Seite
Page
Pagina **118**

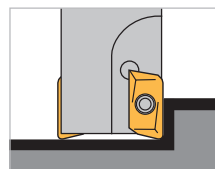

95ES. ..LN10

**Schaftschruppfräser mit
Innenkühlung**
Shank roughing cutter with
internal coolant supply
Frese a riccio gambo cilindrico
con passaggio refrigerante interno

Seite
Page
Pagina **119**

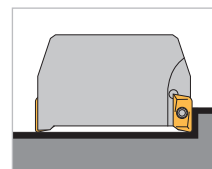

95EA. ..LN10

**Aufsteckschruppfräser mit
Innenkühlung**
Shell type roughing cutter
with internal cooling
Frese a riccio attacco a manicotto
con passaggio refrigerante interno

Seite
Page
Pagina **120**

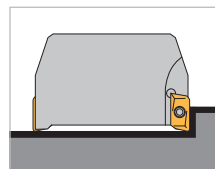

95EA. ..LN15

**Aufsteckschruppfräser mit
Innenkühlung**
Shell type roughing cutter
with internal cooling
Frese a spallamento attacco
a manicotto con passaggio
refrigerante interno

Seite
Page
Pagina **121**

Planfräser

Face milling cutter
Fresa per spianatura

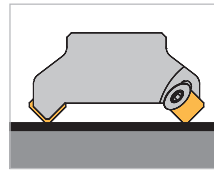

75PA. ..E12

Aufsteckfräser
Shell type milling cutter
Fresa a manicotto

Seite
Page
Pagina **122**

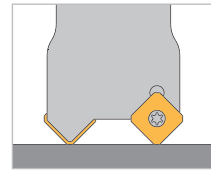

60PS. ..E12

Schafffräser mit Innenkühlung
End mill with internal coolant supply
Fresa con passaggio refrigerante interno

Seite
Page
Pagina **123**

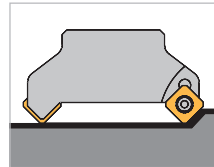

60PA. ..E12

Aufsteckfräser mit Innenkühlung
Shell type milling cutter with internal cooling
Fresa con passaggio refrigerante interno

Seite
Page
Pagina **124**

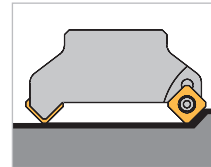

68PA. ..E13

Aufsteckfräser mit Innenkühlung
Face milling cutter
Fresa con passaggio refrigerante interno

Seite
Page
Pagina **125**

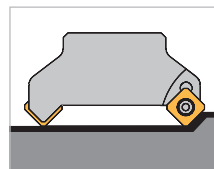

70PA. ..D12

Aufsteckfräser mit Innenkühlung
Shell type milling cutter with internal cooling
Fresa con passaggio refrigerante interno

Seite
Page
Pagina **126**

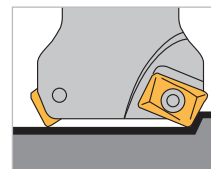

90ESQ. ..P10

Schafffräser mit Innenkühlung
End mill with internal coolant supply
Fresa con passaggio refrigerante interno

Seite
Page
Pagina **127**

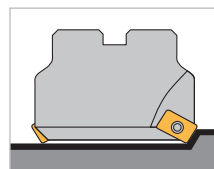

90EAQ. ..P10

Aufsteckfräser mit Innenkühlung
Shell type milling cutter with internal cooling
Fresa con passaggio refrigerante interno

Seite
Page
Pagina **128**

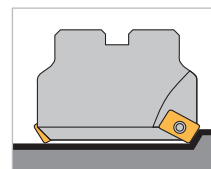

90EAQ. ..P16

Aufsteckfräser mit Innenkühlung
Shell type milling cutter with internal cooling
Fresa con passaggio refrigerante interno

Seite
Page
Pagina **129**

Schaftschruppfräser
Shank roughing cutter
Frese a riccio

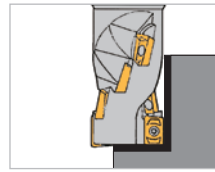

90ESS. ..P10
Schaftfräser mit Innenkühlung
End mill with internal coolant supply
Frese con passaggio refrigerante interno

Seite 130
Page
Pagina

Aufsteckschruppfräser
Shell type roughing cutter
Frese a riccio

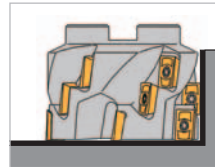

90EAS. ..P10
Aufsteckfräser mit Innenkühlung
Shell type roughing cutter with internal cooling
Frese con passaggio refrigerante interno

Seite 131
Page
Pagina

Schaftschruppfräser
Shank roughing cutter
Frese a riccio

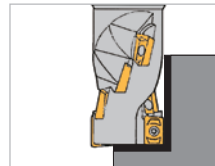

90ESS. ..P16
Schaftfräser mit Innenkühlung
End mill with internal coolant supply
Frese con passaggio refrigerante interno

Seite 132
Page
Pagina

Aufsteckschruppfräser
Shell type roughing cutter
Frese a riccio

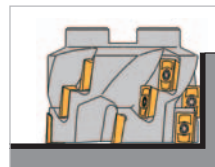

90EAS. ..P16
Aufsteckfräser mit Innenkühlung
Shell type roughing cutter with internal cooling
Frese con passaggio refrigerante interno

Seite 133
Page
Pagina

Scheiben- und Trennfräser
Side and face cutter and slitting cutter
Frese per scanalature e taglio

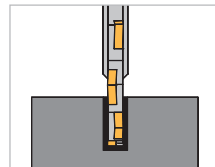

90S610. ..N..
Scheibenfräser mit Längsmitnahme DIN 138
Side and face milling cutter
Frese per scanalature e taglio con attacco DIN 138

Seite 134 – 135
Page
Pagina

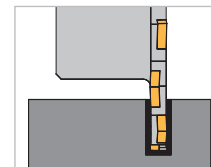

90S610M. ..N..
Scheibenfräser mit Quermittnahme DIN 138
Side and face milling cutter
Frese per scanalature e taglio con attacco DIN 138

Seite 136
Page
Pagina

4

Einschraubfräser

Threaded milling cutter
Fresa con attacco filettato

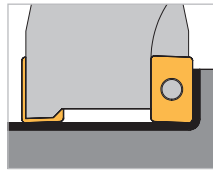

ACME90...

**Einschraubfräser für
Eck-WSP mit Innenkühlung**
Screw shank milling cutter
with internal coolant supply
Fresa a spallamento con pas-
saggio refrigerante interno

Seite
Page
Pagina **137**

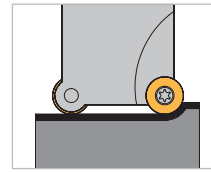

ACME40...

**Einschraubfräser für
Rund-WSP mit Innenkühlung**
Screw shank milling cutter
with internal coolant supply
Fresa a copiare per inserti ton-
di con passaggio refrigerante interno

Seite
Page
Pagina **138**

Planfräser

Face milling cutter
Fresa per spianatura

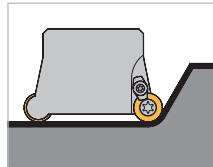

ACMA40...

**Aufsteckfräser für
Rund-WSP mit Innenkühlung**
Shell type milling cutter for round
inserts with internal cooling
Fresa a copiare per inserti ton-
di con passaggio refrigerante interno

Seite
Page
Pagina **139**

Fasfräser

Chamfering cutter
Fresa per smussi

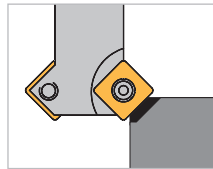

AF45...

Fasfräser
Chamfering cutter
Fresa per smussi

Seite
Page
Pagina **140**

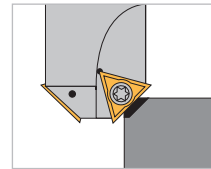

AFS45. ...C16

Fas- und Zentrierfräser
Chamfer and centring cutter
Fresa per smussi, centraggio

Seite
Page
Pagina **141**

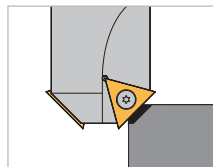

AFS ..C11/C16

Fasfräser
Chamfering cutter
Fresa per smussi

Seite
Page
Pagina **142**

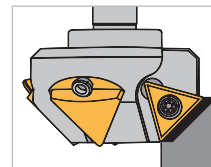

AFS45. ..T16

Fasfräser
Chamfering cutter
Fresa per smussi

Seite
Page
Pagina **143**

Fasfräser, einstellbar

*Chamfering milling cutter,
displacement angle*
Frese per smussi e
svasature registrabile

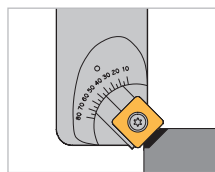

45FS-440V. .. C12

**Fasfräser, einstellbar
von 10° bis 80°**
*Chamfering milling cutter with
adjustable angle from 10° to 80°*
Frese per smussi e svasature
registrabile da 10° a 80°

Seite
Page
Pagina **144**

Fasfräser

Chamfering cutter
Frese per smussi

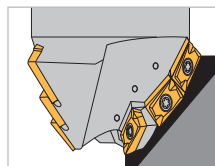

AFA...-P10

**Aufsteckfräser mit
Innenkühlung**
*Shell type chamfering cutter
with internal coolant*
Fresa a manicotto con
passaggio refrigerante interno

Seite
Page
Pagina **145**

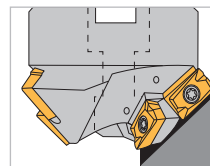

AFA...-P16

**Aufsteckfräser mit
Innenkühlung**
*Shell type chamfering cutter
with internal coolant*
Fresa a manicotto con
passaggio refrigerante interno

Seite
Page
Pagina **146**

Fräser für T-Nuten

T-slot milling cutter
Frese per cave a T

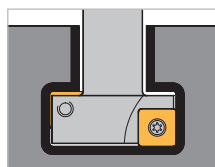

T-976W-..P..

**Schaftfräser mit
Innenkühlung**
*End mill with
internal coolant supply*
Frese con passaggio
refrigerante interno

Seite
Page
Pagina **147**

Bohrnutfräser

Drill and slotting cutter
Frese foranti

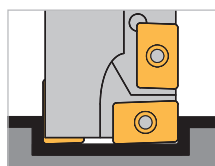

72ES. ..P..

**Schaftfräser mit
Innenkühlung**
*End mill with
internal coolant supply*
Frese con passaggio
refrigerante interno

Seite
Page
Pagina **148**

Senkungsfräser

Indentation milling cutter
Frese per lamature

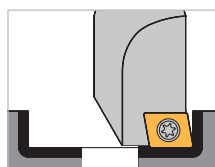

ASF80...

**Senkungsfräser mit
Innenkühlung**
*Indentation milling cutter
with internal coolant supply*
Frese per lamature con addu-
zione interna refrigerante

Seite
Page
Pagina **149**

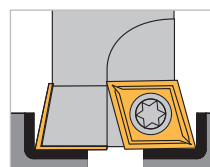

ASF90...

**Senkungsfräser mit
Innenkühlung**
*Indentation milling cutter
with internal coolant supply*
Frese per lamature con addu-
zione interna refrigerante

Seite
Page
Pagina **150**

Einstellbare Feinbohrstangen

Adjustment boring bars
Barenì registrabili per
alesatura

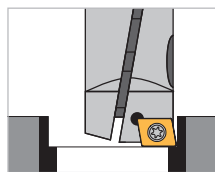

AFB90-.-C..

Schafffräser
Adjustable fine boring bars
Barenò con gambo cilindrico

Seite
Page
Pagina **151**

Rückwärtssenker

Back facing milling cutter
Frese per lamatura a tirare



ARS180-D..

**Schafffräser mit
Innenkühlung**
*End mill with
internal coolant supply*
Frese con passaggio
refrigerante interno

Seite
Page
Pagina **152**

Stahlverlängerungen – konisch

*Steel extensions –
conical*
Adattore in acciaio –
forma conica

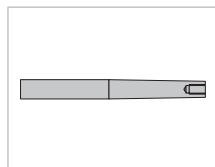

ACV1...

Seite
Page
Pagina **153**

Stahlverlängerungen – zylindrisch

*Steel extensions –
cylindrical*
Adattore in acciaio –
forma cilindrica

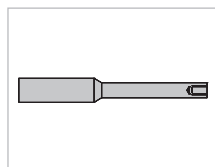

ACV2...

Seite
Page
Pagina **154**

90ES. ..P10

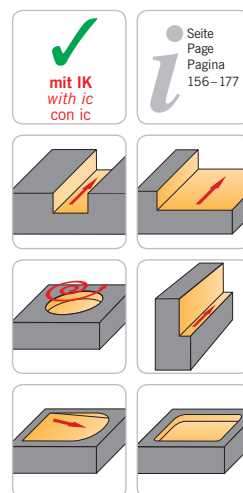
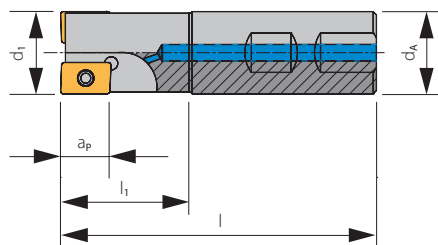

Eckfräser / Square shoulder cutter / Frese per spallamenti retti

Rechte Ausführung abgebildet
 Right-hand execution shown
 Versione destra in figura

Schafffräser End mill Fresa cilindrica	d_1	d_a	l	l_1	a_p	z	Wendeschneidplatte Indexable insert Inserto
90ES.010R.P10	10	16	80	24	9	1	AP.. 1003...
90ES.011R.P10	11	16	80	24	9	1	AP.. 1003...
90ES.012R.P10	12	16	80	24	9	1	AP.. 1003...
90ES.013R.P10	13	16	80	24	9	1	AP.. 1003...
90ES.014R.P10	14	16	80	24	9	1	AP.. 1003...
90ES.015R.P10	15	16	85	25	9	2	AP.. 1003...
90ES.015,7R.P10	15,7	16	85	25	9	2	AP.. 1003...
90ES.016R.P10	16	16	85	25	9	2	AP.. 1003...
90ES.017R.P10	17	16	85	25	9	2	AP.. 1003...
90ES.018R.P10	18	20	85	25	9	2	AP.. 1003...
90ES.019,7R.P10	19,7	20	90	25	9	3	AP.. 1003...
90ES.020R.P10	20	20	90	25	9	3	AP.. 1003...
90ES.022R.P10	22	25	95	25	9	3	AP.. 1003...
90ES.024,7R.P10	24,7	25	95	25	9	4	AP.. 1003...
90ES.025R.P10	25	25	95	25	9	3	AP.. 1003...
90ES.025/4R.P10	25	25	95	25	9	4	AP.. 1003...
90ES.028R.P10	28	25	95	25	9	4	AP.. 1003...
90ES.030R.P10	30	25	95	25	9	4	AP.. 1003...
90ES.031,7R.P10	31,7	25	95	26	9	5	AP.. 1003...
90ES.032R.P10	32	25	95	26	9	5	AP.. 1003...
90ESL.010R.P10	10	16	150	24	9	1	AP.. 1003...
90ESL.012R.P10	12	16	150	24	9	1	AP.. 1003...
90ESL.016R.P10	16	16	150	24	9	2	AP.. 1003...
90ESL.018R.P10	18	16	150	25	9	2	AP.. 1003...
90ESL.020R.P10	20	20	150	25	9	3	AP.. 1003...
90ESL.025R.P10	25	20	150	25	9	4	AP.. 1003...
90ESL.032R.P10	32	25	150	26	9	5	AP.. 1003...

z = Anzahl Wendeschneidplatten
z = Number of inserts
z = Numero di inserti

Ersatzteile / Spare parts / Ricambi

Bezeichnung Designation Articolo	Spannschraube Screw Vite	Schraubendreher Screw driver Chiave
90ES. ..R.P10	SS 1225	T 5108

90EA. ..P10

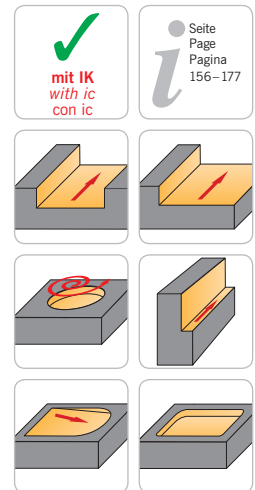
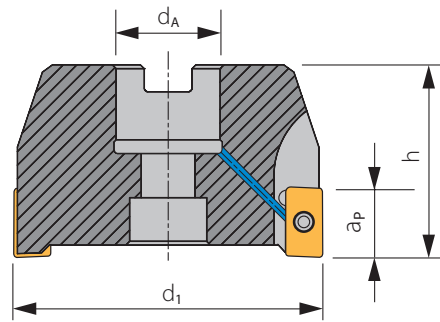

Eckfräser / Square shoulder cutter / Frese per spallamenti retti

Rechte Ausführung abgebildet
 Right-hand execution shown
 Versione destra in figura

Aufsteckfräser Shell type milling cutter Fresa a manicotto	d_1	d_A	h	a_p	z	Wendeschneidplatte Indexable insert Inserto
90EA.040R.P10	40	16	40	9	6	AP.. 1003...
90EA.050R.P10	50	22	40	9	7	AP.. 1003...
90EA.063R.P10	63	22	40	9	8	AP.. 1003...
90EA.080R.P10	80	27	50	9	11	AP.. 1003...
90EA.100R.P10	100	32	50	9	12	AP.. 1003...

z = Anzahl Wendeschneidplatten
 z = Number of inserts
 z = Numero di inserti



Ersatzteile / Spare parts / Ricambi

Bezeichnung Designation Articolo	Spannschraube Screw Vite	Schraubendreher Screw driver Chiave
90EA. ..R.P10	SS 1225	T 5108

90ES. ..P16

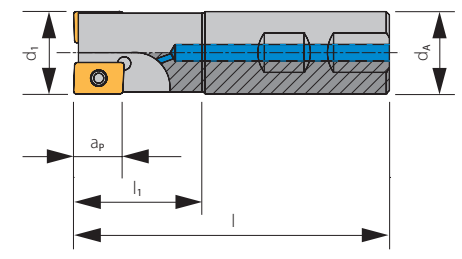
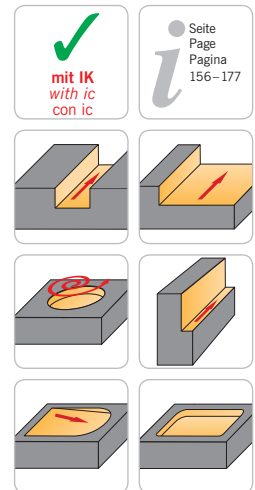

Rechte Ausführung abgebildet
 Right-hand execution shown
 Versione destra in figura

Eckfräser / Square shoulder cutter / Frese per spallamenti retti

Schaftfräser End mill Fresa cilindrica	d_i	d_A	l	l_1	a_p	z	Wendeschneidplatte Indexable insert Inserto
90ES.025RI.P16	25	25	100	44	15	2	AP.. 1604...
90ES.032RI.P16	32	32	110	50	15	3	AP.. 1604...
90ES.040RI.P16	40	32	115	45	15	4	AP.. 1604...
90ESL.022R.P16	22	20	200	60	15	2	AP.. 1604...
90ESL.025R.P16	25	25	200	60	15	2	AP.. 1604...
90ESL.032R.P16	32	32	200	60	15	3	AP.. 1604...
90ESL.040R.P16	40	32	200	60	15	4	AP.. 1604...

z = Anzahl Wendeschneidplatten
 z = Number of inserts
 z = Numero di inserti

4

Ersatzteile / Spare parts / Ricambi

Bezeichnung Designation Articolo	Spannschraube Screw Vite	Schraubendreher Screw driver Chiave
90ES. ..R.P16	SS 1240	T 5115

90EA. ..P16

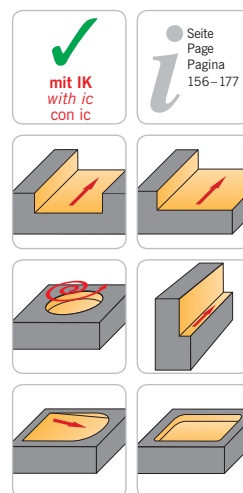
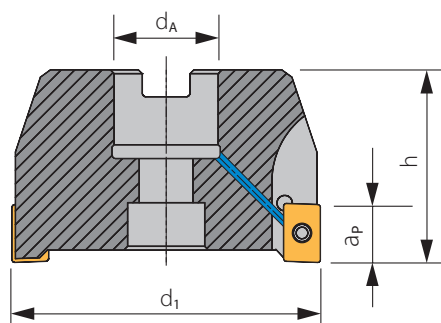

Eckfräser / Square shoulder cutter / Frese per spallamenti retti

Rechte Ausführung abgebildet
 Right-hand execution shown
 Versione destra in figura

Aufsteckfräser Shell type roughing cutter Fresa a manicotto	d ₁	d _A	h	a _p	z	Wendeschneidplatte Indexable insert Inserto
90EA.040RI.P16	40	16	40	15	4	AP.. 1604...
90EA.050RI.P16	50	22	40	15	5	AP.. 1604...
90EA.063RI.P16	63	22	40	15	6	AP.. 1604...
90EA.080RI.P16	80	27	50	15	7	AP.. 1604...
90EA.100RI.P16	100	32	50	15	8	AP.. 1604...
90EA.125RI.P16	125	40	63	15	9	AP.. 1604...
90EA.160R.P16*	160	40	63	15	10	AP.. 1604...
90EA.200R.P16*	200	60	63	15	13	AP.. 1604...
90EA.250R.P16*	250	60	63	15	16	AP.. 1604...

* ohne Innenkühlung
 * without internal coolant
 * senza adduzione interna

z = Anzahl Wendeschneidplatten
 z = Number of inserts
 z = Numero di inserti



Ersatzteile / Spare parts / Ricambi

Bezeichnung Designation Articolo	Spannschraube Screw Vite	Schraubendreher Screw driver Chiave
90EA. ..R.P16	SS 1240	T 5115

90EA. ..D12

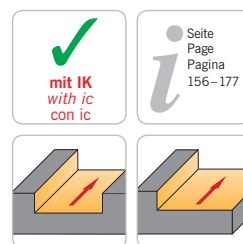
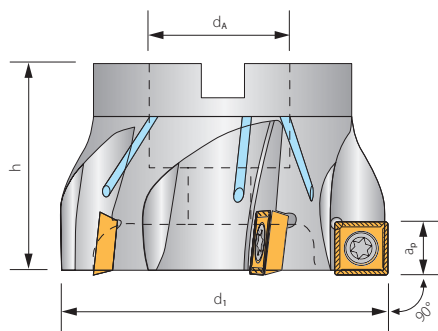

Plan-Eckfräser

Square shoulder milling cutter with internal coolant supply

Frese per spianatura – spallamenti retti

Rechte Ausführung abgebildet
 Right-hand execution shown
 Versione destra in figura

Aufsteckfräser Shell type milling cutter Fresa a manicotto	d_1	d_A	h	a_p	z	Wendeschneidplatte Indexable insert Inserto
90EA.40R.D12	40	16	40	10,5	4	SDMT 1205...
90EA.50R.D12	50	22	40	10,5	5	SDMT 1205...
90EA.63R.D12	63	22	40	10,5	6	SDMT 1205...
90EA.80R.D12	80	27	50	10,5	6	SDMT 1205...
90EA.100R.D12	100	32	50	10,5	8	SDMT 1205...
90EA.125R.D12	125	40	63	10,5	9	SDMT 1205...

z = Anzahl Wendeschneidplatten
 z = Number of inserts
 z = Numero di inserti

4

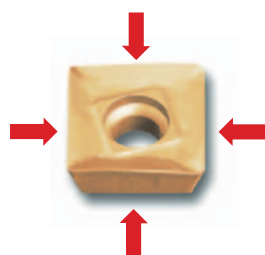

Vier Schneidkanten
 Four cutting edges
 Quattro taglienti

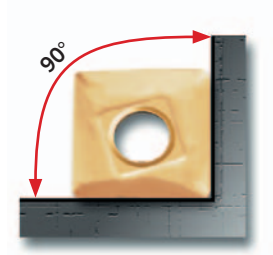

Exakt 90°-Ecken am Werkstück
 Exact 90° corners on the workpiece
 Spallamento retto a 90° sul pezzo

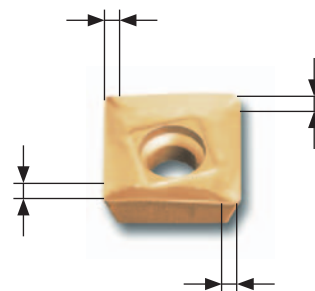

Vier Planfasen
 Four minor cutting edges
 Quattro fasi raschianti

Ersatzteile / Spare parts / Ricambi

Bezeichnung Designation Articolo	Spannschraube Screw Vite	Schraubendreher Screw driver Chiave
90EA. ..D12	SS 1290	T 5115

95ES. ..LN10

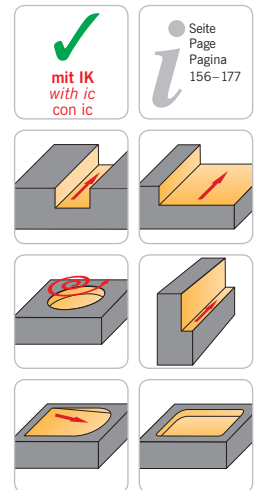
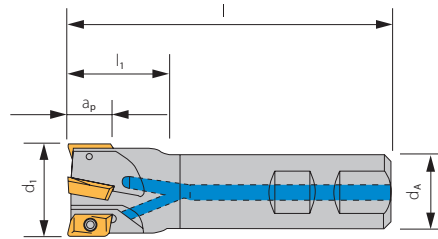

Rechte Ausführung abgebildet
 Right-hand execution shown
 Versione destra in figura

Eckschruppfräser

Square shoulder roughing cutter
 Frese a riccio per spallamenti retti

Schaftfräser End mill Fresa cilindrica	d ₁	d _A	l	l ₁	a _p	z	Wendeschneidplatte Indexable insert Inserto
95ES.020R.LN10	20	20	100	30	9	3	LNMX 10...
95ES.025R.LN10	25	25	115	35	9	3	LNMX 10...
95ES.032R.LN10	32	25	115	40	9	4	LNMX 10...

z = Anzahl Wendeschneidplatten
 z = Number of inserts
 z = Numero di inserti



Ersatzteile / Spare parts / Ricambi

Bezeichnung Designation Articolo	Spannschraube Screw Vite	Schraubendreher Screw driver Chiave
95ES. ..R.LN10	AS 0071	T 5108

95EA. ..LN10

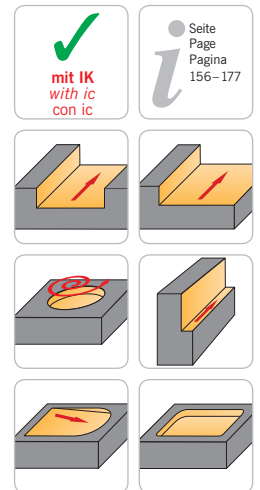
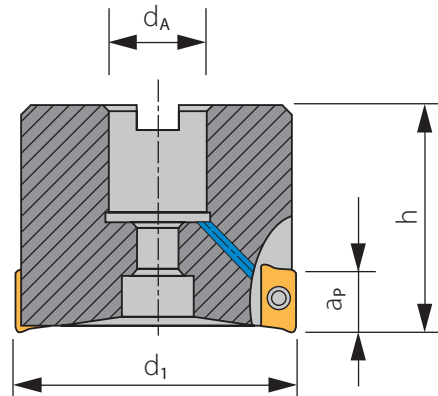

Rechte Ausführung abgebildet
 Right-hand execution shown
 Versione destra in figura

Eckschruppfräser

Square shoulder roughing cutter

Fresa a riccio per spallamenti retti

Aufsteckfräser Shell type milling cutter Fresa a manicotto	d_1	d_A	h	a_p	z	Wendeschneidplatte Indexable insert Inserto
95EA.040R.LN10	40	16	40	9	5	LNMX 10...
95EA.050R.LN10	50	22	40	9	7	LNMX 10...
95EA.063R.LN10	63	22	40	9	9	LNMX 10...

z = Anzahl Wendeschneidplatten
 z = Number of inserts
 z = Numero di inserti

4

Ersatzteile / Spare parts / Ricambi

Bezeichnung Designation Articolo	Spannschraube Screw Vite	Schraubendreher Screw driver Chiave
95EA. ..R.LN10	AS 0071	T 5108

95EA. ..LN15

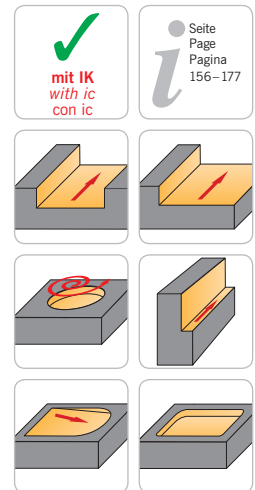
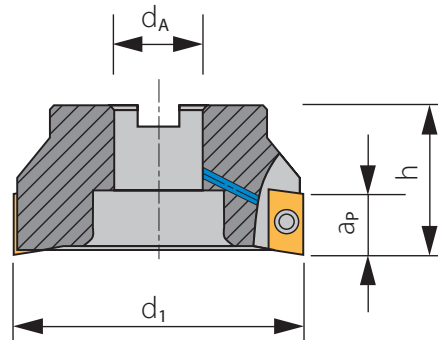
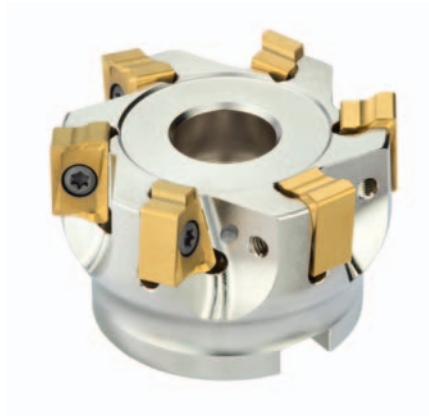

Rechte Ausführung abgebildet
 Right-hand execution shown
 Versione destra in figura

Eckschruppfräser

Square shoulder roughing cutter

Fresa a riccio per spallamenti retti

Aufsteckfräser Shell type milling cutter Fresa a manicotto	d_1	d_A	h	a_p	z	Wendeschneidplatte Indexable insert Inserto
95EA.050R.LN15	50	22	40	14	5	LNMX 15...
95EA.063R.LN15	63	22	40	14	6	LNMX 15...
95EA.080R.LN15	80	27	50	14	7	LNMX 15...
95EA.100R.LN15	100	32	50	14	8	LNMX 15...
95EA.125R.LN15	125	40	63	14	10	LNMX 15...

z = Anzahl Wendeschneidplatten
 z = Number of inserts
 z = Numero di inserti



Ersatzteile / Spare parts / Ricambi

Bezeichnung Designation Articolo	Spannschraube Screw Vite	Schraubendreher Screw driver Chiave
95EA. ..R.LN15	AS 0073	T 5115

75PA. ..E12

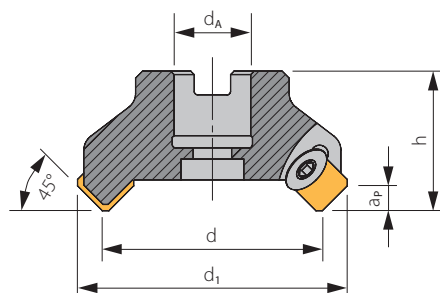
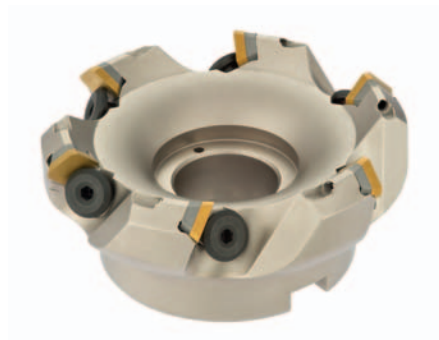

Planfräser / Face milling cutter / Frese per spianatura

Rechte Ausführung abgebildet
 Right-hand execution shown
 Versione destra in figura

Aufsteckfräser Shell type milling cutter Fresa a manicotto	d	d ₁	d _A	d ₂	h	a _p	z	Wendeschneidplatte Indexable insert Inserto
75PA.50R.E12	50	63	22	-	48	5,5	4	SE.. 1203...
75PA.63R.E12	63	76	22	-	40	5,5	5	SE.. 1203...
75PA.80R.E12	80	93	27	-	50	5,5	6	SE.. 1203...
75PA.100R.E12	100	113	32	-	50	5,5	6	SE.. 1203...
75PA.125R.E12	125	138	40	-	63	5,5	7	SE.. 1203...
75PA.160R.E12	160	173	40	66,7	63	5,5	7	SE.. 1203...
75PA.200R.E12	200	213	60	101,7	63	5,5	10	SE.. 1203...
75PA.250R.E12	250	263	60	101,7	63	5,5	13	SE.. 1203...

d₂ = Lochabstand Befestigungsschrauben für Fräsdorn
d₂ = Hole distance locking screw for milling arbor
d₂ = interasse fori viti bloccaggio fresa per attacco diretto mandrino

z = Anzahl Wendeschneidplatten
z = Number of inserts
z = Numero di inserti

Ersatzteile / Spare parts / Ricambi

Bezeichnung Designation Articolo	Unterlagplatte Support Sottoplacchetta	Schraube für Unterlagplatte Screw support Vite sottoplacchetta	Spannschraube WSP Insert locking screw Vite di bloccaggio	Schlüssel-Unterlage Key support Chiave sottoplacchetta	Schlüssel-Klemmschraube Key clamping screw Chiave vite
75PA. ..E12	AKE 12,4	VF 4	CVB 55	KP 3421	KP 1321

60PS. ..E12

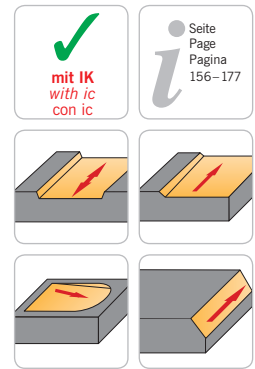
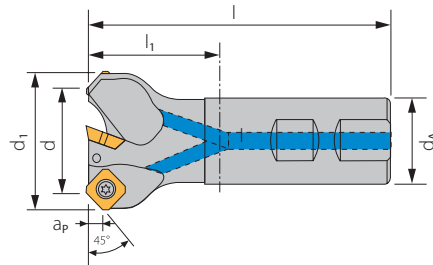

Planfräser / Face milling cutter / Frese per spianatura

Rechte Ausführung abgebildet
 Right-hand execution shown
 Versione destra in figura

Schafffräser End mill Fresa cilindrica	d	d ₁	d _A	l	l ₁	a _p	z	Wendeschneidplatte Indexable insert Inserto
60PS.25RI.E12	25	38	25	100	44	5,5	2	SE.. 1204 ...
60PS.32RI.E12	32	45	25	110	54	5,5	3	SE.. 1204 ...
60PS.40RI.E12	40	53	32	115	55	5,5	4	SE.. 1204 ...

z = Anzahl Wendeschneidplatten
 z = Number of inserts
 z = Numero di inserti



Ersatzteile / Spare parts / Ricambi

Bezeichnung Designation Articolo	Spannschraube Screw Vite	Schraubendreher Screw driver Chiave
60PS. ..R.E12	FS 243	T 5120

60PA. ..E12

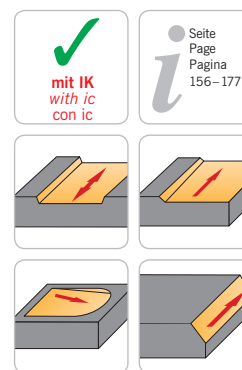
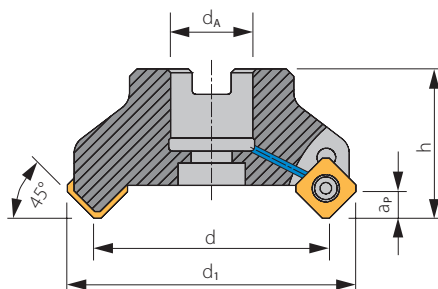
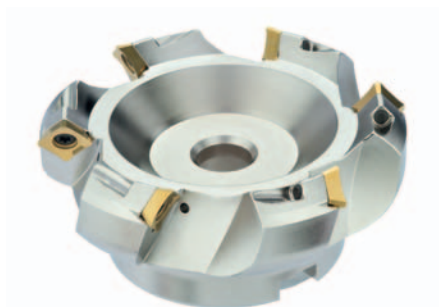

Planfräser / Face milling cutter / Frese per spianatura

Rechte Ausführung abgebildet
 Right-hand execution shown
 Versione destra in figura

Aufsteckfräser Shell type milling cutter Fresa a manicotto	d	d ₁	d _A	h	a _p	z	Wendeschneidplatte Indexable insert Inserto
60PA.40R.E12-3	40	53	16	40	5,5	3	SE.. 1204...
60PA.40R.E12-4	40	53	16	40	5,5	4	SE.. 1204...
60PA.50R.E12-4	50	63	22	48	5,5	4	SE.. 1204...
60PA.50R.E12-5	50	63	22	48	5,5	5	SE.. 1204...
60PA.63R.E12-5	63	76	22	48	5,5	5	SE.. 1204...
60PA.63R.E12-6	63	76	22	48	5,5	6	SE.. 1204...
60PA.80R.E12-6	80	93	27	50	5,5	6	SE.. 1204...
60PA.80R.E12-7	80	93	27	50	5,5	7	SE.. 1204...
60PA.100R.E12-6	100	113	32	50	5,5	6	SE.. 1204...
60PA.100R.E12-8	100	113	32	50	5,5	8	SE.. 1204...
60PA.125R.E12-7	125	138	40	63	5,5	7	SE.. 1204...
60PA.125R.E12-9	125	138	40	63	5,5	9	SE.. 1204...
60PA.160R.E12-8	160	173	40	63	5,5	8	SE.. 1204...
60PA.160R.E12-10	160	173	40	63	5,5	10	SE.. 1204...
60PA.200R.E12-12*	200	213	60	63	5,5	12	SE.. 1204...
60PA.250R.E12-16*	250	263	60	63	5,5	16	SE.. 1204...

* ohne Innenkühlung
 * without internal coolant
 * senza adduzione interna

z = Anzahl Wendeschneidplatten
 z = Number of inserts
 z = Numero di inserti

Ersatzteile / Spare parts / Ricambi

Bezeichnung Designation Articolo	Spannschraube Screw Vite	Schraubendreher Screw driver Chiave
60PA. ..E12	FS 243	T 5120

68PA. ..E13

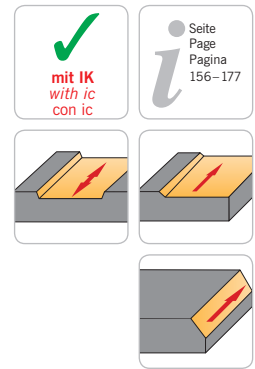
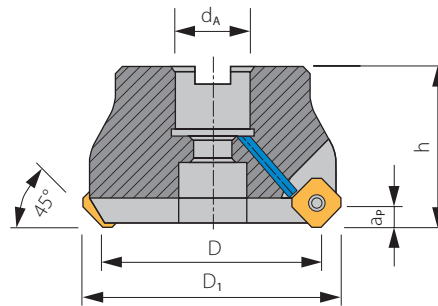

Planfräser / Face milling cutter / Frese per spianatura

Rechte Ausführung abgebildet
 Right-hand execution shown
 Versione destra in figura

Aufsteckfräser Shell type milling cutter Fresa a manicotto	D	D ₁	d _A	h	a _p	z	Wendeschneidplatte Indexable insert Inserto
68PA.50R.E13-4	50	63	22	40	6	4	SE.. 13T3...
68PA.50R.E13-5	50	63	22	40	6	5	SE.. 13T3...
68PA.63R.E13-5	63	76	22	40	6	5	SE.. 13T3...
68PA.63R.E13-6	63	76	22	40	6	6	SE.. 13T3...
68PA.80R.E13-6	80	93	27	50	6	6	SE.. 13T3...
68PA.80R.E13-8	80	93	27	50	6	8	SE.. 13T3...
68PA.100R.E13-7	100	113	32	50	6	7	SE.. 13T3...
68PA.100R.E13-10	100	113	32	50	6	10	SE.. 13T3...
68PA.125R.E13-8	125	138	40	63	6	8	SE.. 13T3...
68PA.125R.E13-12	125	138	40	63	6	12	SE.. 13T3...
68PA.160R.E13-10*	160	173	40	63	6	10	SE.. 13T3...
68PA.160R.E13-16*	160	173	40	63	6	16	SE.. 13T3...
68PA.200R.E13-12*	200	213	60	63	6	12	SE.. 13T3...
68PA.250R.E13-16*	250	263	60	63	6	16	SE.. 13T3...

* ohne Innenkühlung
 * without internal coolant
 * senza adduzione interna

z = Anzahl Wendeschneidplatten
 z = Number of inserts
 z = Numero di inserti

Ersatzteile / Spare parts / Ricambi

Bezeichnung Designation Articolo	Spannschraube Screw Vite	Schraubendreher Screw driver Chiave
68PA. ..R.E13	AS 0072	T 5115



70PA. ..D12

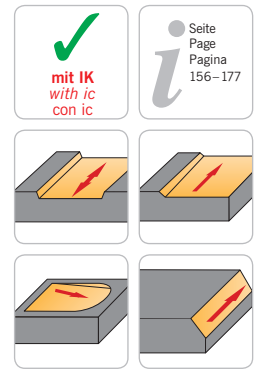
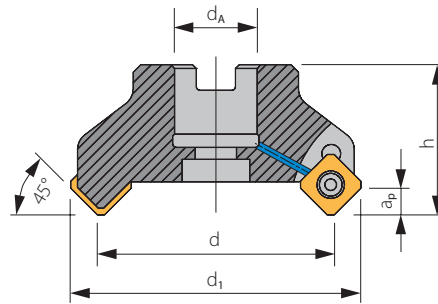
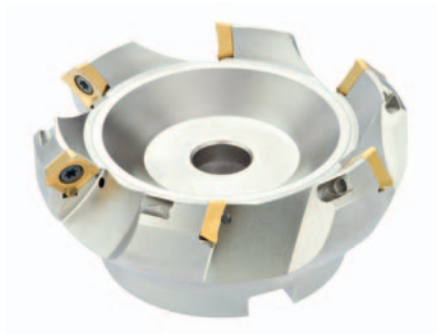

Planfräser / Face milling cutter / Frese per spianatura

Rechte Ausführung abgebildet
 Right-hand execution shown
 Versione destra in figura

Aufsteckfräser Shell type milling cutter Fresa a manicotto	d	d ₁	d _A	h	a _p	z	Wendeschneidplatte Indexable insert Inserto
70PA.50R.D12	50	63	22	48	5,5	4	SD.. 1204...
70PA.63R.D12	63	76	22	48	5,5	5	SD.. 1204...
70PA.80R.D12	80	93	27	50	5,5	6	SD.. 1204...
70PA.100R.D12	100	113	32	50	5,5	6	SD.. 1204...
70PA.125R.D12	125	138	40	63	5,5	7	SD.. 1204...
70PA.160R.D12	160	173	40	63	5,5	8	SD.. 1204...
70PA.200R.D12*	200	213	60	63	5,5	12	SD.. 1204...
70PA.250R.D12*	250	263	60	63	5,5	16	SD.. 1204...

* ohne Innenkühlung
* without internal coolant
* senza adduzione interna

z = Anzahl Wendeschneidplatten
z = Number of inserts
z = Numero di inserti

Ersatzteile / Spare parts / Ricambi

Bezeichnung Designation Articolo	Spannschraube Screw Vite	Schraubendreher Screw driver Chiave
70PA. ..R.D12	SS 1221	T 5120

90ESQ. ..P10

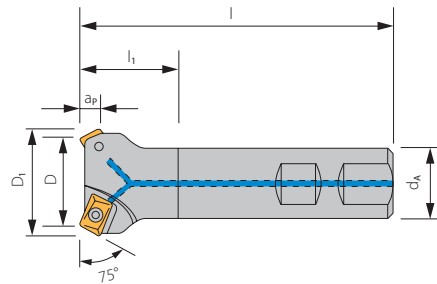
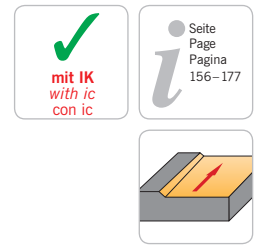

Planfräser / Face milling cutter / Frese per spianatura – 75°

Rechte Ausführung abgebildet
 Right-hand execution shown
 Versione destra in figura

Schafffräser mit Innenkühlung (75°) End mill with internal coolant supply (75°) Frese con passaggio refrigerante interno (75°)	D	D ₁	d _A	l	l ₁	a _p	z	Wendeschneidplatte Indexable insert Inserto
90ESQ.025R.P10	25	28,6	20	95	25	4	2	AP.. 1003...
90ESQ.032R.P10	32	35,6	25	95	25	4	3	AP.. 1003...
90ESQ.040R.P10	40	43,6	25	100	25	4	4	AP.. 1003...

z = Anzahl Wendeschneidplatten
 z = Number of inserts
 z = Numero di inserti



Ersatzteile / Spare parts / Ricambi

Bezeichnung Designation Articolo	Spannschraube Screw Vite	Schraubendreher Screw driver Chiave
90ESQ. ..R.P10	SS 1225	T 5108

90EAQ. ..P10

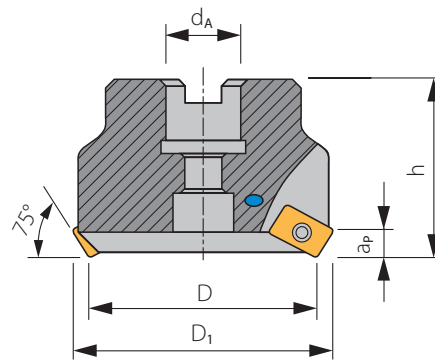
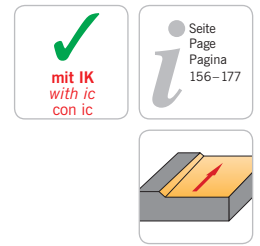

Planfräser / Face milling cutter / Frese per spianatura – 75°

Rechte Ausführung abgebildet
 Right-hand execution shown
 Versione destra in figura

Aufsteckfräser Shell type milling cutter Fresa a manicotto	D	D ₁	d _A	h	a _p	z	Wendeschneidplatte Indexable insert Inserto
90EAQ.050R.P10	50	54	22	40	4	5	AP.. 1003...
90EAQ.063R.P10	63	67	22	40	4	6	AP.. 1003...

z = Anzahl Wendeschneidplatten
z = Number of inserts
z = Numero di inserti

4

Ersatzteile / Spare parts / Ricambi

Bezeichnung Designation Articolo	Spannschraube Screw Vite	Schraubendreher Screw driver Chiave
90EAQ. ..R.P10	SS 1225	T 5108

90EAQ. ..P16

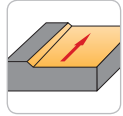
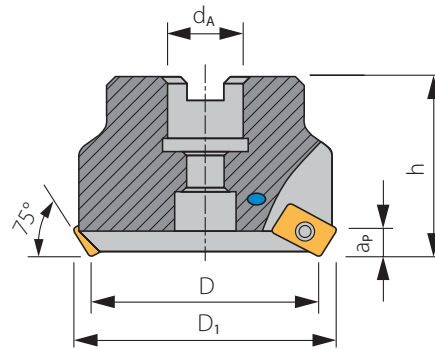
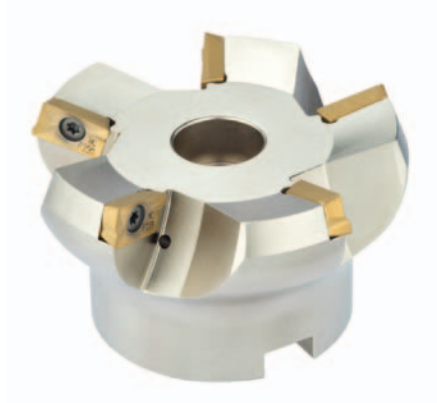

Planfräser / Face milling cutter / Frese per spianatura – 75°

Rechte Ausführung abgebildet
 Right-hand execution shown
 Versione destra in figura

Aufsteckfräser Shell type milling cutter Fresa a manicotto	D	D ₁	d _A	h	a _p	z	Wendeschneidplatte Indexable insert Inserto
90EAQ.050R.P16	50	54	16	40	6,5	3	AP.. 1604...
90EAQ.063R.P16	63	67	22	40	6,5	4	AP.. 1604...
90EAQ.080R.P16	80	84	27	50	6,5	5	AP.. 1604...
90EAQ.100R.P16	100	104	32	50	6,5	6	AP.. 1604...
90EAQ.125R.P16	125	129	40	63	6,5	7	AP.. 1604...

z = Anzahl Wendeschneidplatten
z = Number of inserts
z = Numero di inserti



Ersatzteile / Spare parts / Ricambi

Bezeichnung Designation Articolo	Spannschraube Screw Vite	Schraubendreher Screw driver Chiave
90EAQ. ..R.P16	SS 1240	T 5115

90ESS..P10

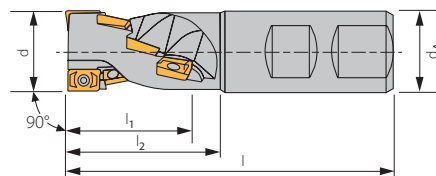
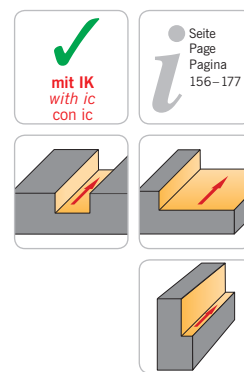

Schaftschruppfräser
 Shank roughing cutter
 Frese a riccio gambo cilindrico

Rechte Ausführung abgebildet
 Right-hand execution shown
 Versione destra in figura

Schaftfräser End mill Fresa cilindrica	d	d _A	l	l ₁	l ₂	K	z	n	Wendeschneidplatte Indexable insert Inserto
90ESS.020R.P10	20	20	86	28	35	1	4	1	AP.. 1003...
90ESS.025R.P10	25	25	100	36	45	2	8	2	AP.. 1003...
90ESS.032R.P10	32	32	120	45	55	2	12	3	AP.. 1003...
90ESS.032/3R.P10	32	32	120	45	55	3	15	3	AP.. 1003...
90ESS.040R.P10	40	32	130	54	65	2	14	4	AP.. 1003...

K = Vorschubfaktor
 K = Forward feed factor
 K = Fattore d'avanzamento

z = Anzahl Wendeschneidplatten
 z = Number of inserts
 z = Numero di inserti

n = Zahnreihen
 n = Number of teeth row
 n = Numero di taglienti effettivo

Ersatzteile / Spare parts / Ricambi

Bezeichnung Designation Articolo	Spannschraube Screw Vite	Schraubendreher Screw driver Chiave
90ESS..R.P10	SS 1225	T 5108

Besäumen
 Periphery milling
 Fresatura in contornatura

Nutfräsen
 Slotting
 Fresatura cave

Besäumen: Beispiele zur Berechnung der Vorschubkorrektur f_z
 Periphery milling: Example for calculation the feed correction f_z
 Fresatura tangenziale: esempi di calcolo per la correzione dell'avanzamento f_z
 (spessore medio truciolo)

Vordefinierte Werte / Pre-set values / Valori predefiniti:

Werkzeugdurchmesser

Cutter diameter
 Diametro dell'utensile **D = Ø 20 mm**

Eingriffsbreite

Cutting width
 Fascia di presa **ae = 4 mm**

Gewählter Vorschub

Selected feed per tooth
 Avanzamento per dente scelto **fz = 0,15 mm/Zahn**

Beispiel / Example / Esempio: $\frac{ae}{D} = \frac{4 \text{ mm}}{20 \text{ mm}} = 0,2$

Vc = 1,4 x f_c = Vorschubkorrektur laut Tabelle Seite 161
 Feed correction acc.to table page 161
 Correzione dell'avanzamento in riferimento alla tabella pag. 161

Korrigierter Vorschub / Corrected feed rate / Avanzamento corretto:

Vc = 1,4 x 0,15 = **0,21 mm Vorschub pro Zahn**
 feed rate per tooth
 Avanzamento per dente

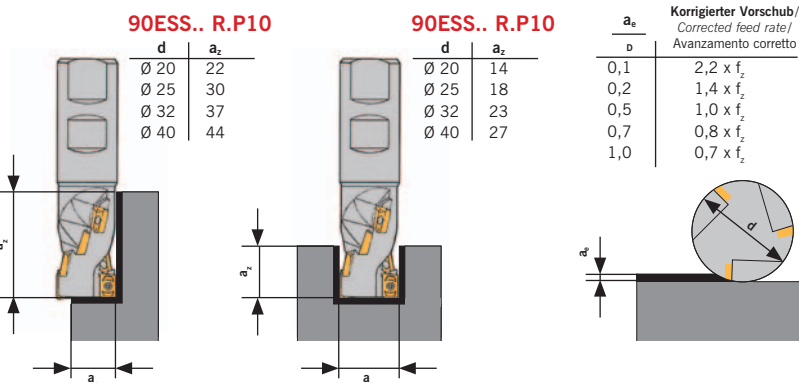

Achtung: Vorschub ist abhängig von der Eingriffsbreite!
 Attention: Feed rate in relation to working width!
 Attenzione: l'avanzamento è in funzione della fascia in presa!

90EAS. ..P10

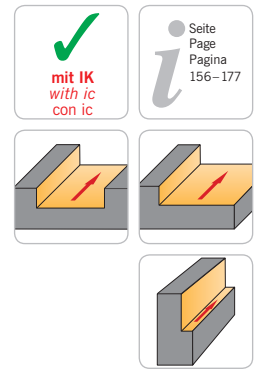
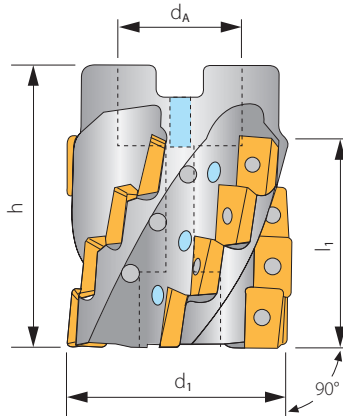

Aufsteckschruppfräser
Shell type roughing cutter

Fresa a riccio attacco a manicotto

Rechte Ausführung abgebildet
Right-hand execution shown
Versione destra in figura

Aufsteckfräser Shell type milling cutter Fresa a manicotto	d ₁	d _A	h	l ₁	K	z	Wendeschneidplatte Indexable insert Inserto
90EAS.040R.P10	40	16	50	37	3	12	AP.. 1003...
90EAS.050R.P10	50	22	60	46	3	15	AP.. 1003...
90EAS.063R.P10	63	27	60	46	4	20	AP.. 1003...

K = Vorschubfaktor
K = Forward feed factor
K = Fattore d'avanzamento

z = Anzahl Wendeschneidplatten
z = Number of inserts
z = Numero di inserti



Ersatzteile / Spare parts / Ricambi

Bezeichnung Designation Articolo	Spannschraube Screw Vite	Schraubendreher Screw driver Chiave
90EAS. ..R.P10	SS 1225	T 5108

90ESS..P16

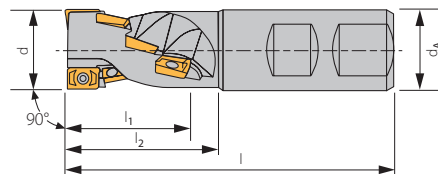
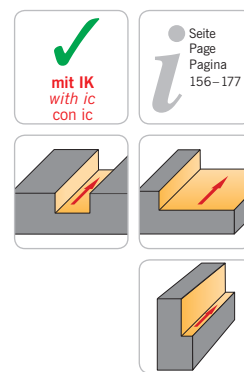

Schaftschruppfräser
 Shank roughing cutter
 Frese a riccio gambo cilindrico

Rechte Ausführung abgebildet
 Right-hand execution shown
 Versione destra in figura

Schaftfräser End mill Fresa cilindrica	d	d _A	l	l ₁	l ₂	K	z	n	Wendeschneidplatte Indexable insert Inserto
90ESS.025R.P16	25	25	105	29	50	1	2	1	AP.. 1604...
90ESS.032R.P16	32	32	115	44	55	2	6	2	AP.. 1604...
90ESS.040R.P16	40	32	130	58	68	2	8	2	AP.. 1604...

K = Vorschubfaktor
K = Forward feed factor
K = Fattore d'avanzamento

z = Anzahl Wendeschneidplatten
z = Number of inserts
z = Numero di inserti

n = Zahnreihen
n = Number of teeth row
n = Numero di taglienti effettivo

4

Ersatzteile / Spare parts / Ricambi

Bezeichnung Designation Articolo	Spannschraube Screw Vite	Schraubendreher Screw driver Chiave
90ESS..R.P16	SS 1240	T 5115

Besäumen
 Periphery milling
 Fresatura in contornatura

Nutfräsen
 Slotting
 Fresatura cave

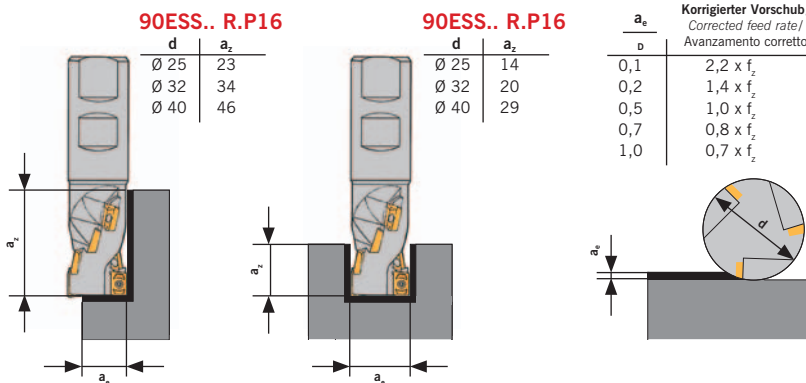

Achtung: Vorschub ist abhängig von der Eingriffsbreite!
 Attention: Feed rate in relation to working width!
 Attenzione: l'avanzamento è in funzione della fascia in presa!

Besäumen: Beispiele zur Berechnung der Vorschubkorrektur f_z
 Periphery milling: Example for calculation the feed correction f_z
 Fresatura tangenziale: esempi di calcolo per la correzione dell'avanzamento f_z (spessore medio truciolo)

Vordefinierte Werte / Pre-set values / Valori predefiniti:

Werkzeugdurchmesser
 Cutter diameter
 Diametro dell'utensile **D = Ø 20 mm**

Eingriffsbreite
 Cutting width
 Fascia di presa **ae = 4 mm**

Gewählter Vorschub
 Selected feed per tooth
 Avanzamento per dente scelto **fz = 0,15 mm/Zahn**

Beispiel / Example / Esempio: $\frac{ae}{D} = \frac{4 \text{ mm}}{20 \text{ mm}} = 0,2$

Vc = 1,4 x f_c = Vorschubkorrektur laut Tabelle Seite 161
 Feed correction acc.to table page 161
 Correzione dell'avanzamento in riferimento alla tabella pag. 161

Korrigierter Vorschub / Corrected feed rate / Avanzamento corretto:
 Vc = 1,4 x 0,15 = 0,21 mm Vorschub pro Zahn
 feed rate per tooth
 Avanzamento per dente

90EAS. ..P16

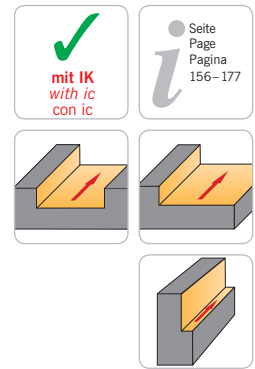
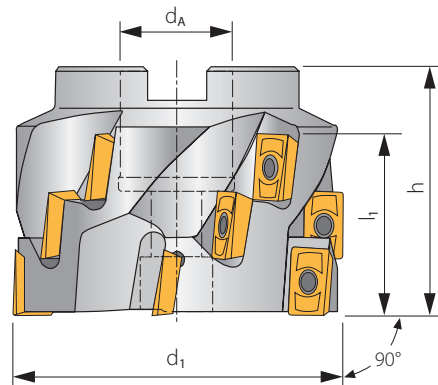
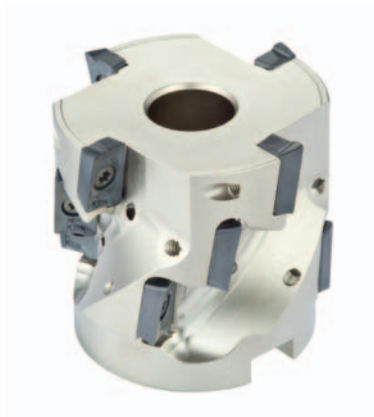

Aufsteckschrupfräser
Shell type roughing cutter

Frese a riccio attacco a manicotto

Rechte Ausführung abgebildet
Right-hand execution shown
Versione destra in figura

Aufsteckfräser Shell type milling cutter Fresa a manicotto	d ₁	d _A	h	l ₁	K	z	Wendeschneidplatte Indexable insert Inserto
90EAS.050R.P16	50	27	50	30	3	6	AP.. 1604...
90EAS.063R.P16	63	27	60	44	4	12	AP.. 1604...
90EAS.080R.P16	80	32	60	44	5	15	AP.. 1604...
90EAS.100R.P16	100	40	60	44	6	18	AP.. 1604...

K = Vorschubfaktor
K = Forward feed factor
K = Fattore d'avanzamento

z = Anzahl Wendeschneidplatten
z = Number of inserts
z = Numero di inserti

Ersatzteile / Spare parts / Ricambi

Bezeichnung Designation Articolo	Spannschraube Screw Vite	Schraubendreher Screw driver Chiave
90EAS. ..R.P16	SS 1240	T 5115



90S610. ..N..

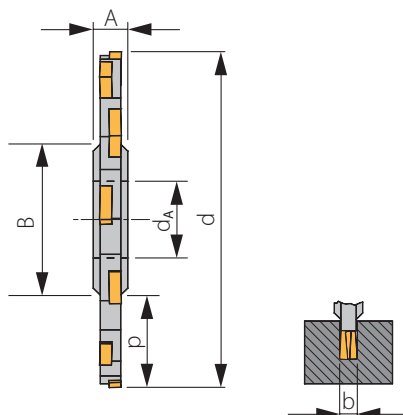

Scheiben- und Trennfräser
Side and face milling cutter
 Frese per scanalature e taglio

Rechte Ausführung abgebildet
 Right-hand execution shown
 Versione destra in figura

4

Aufsteckfräser Shell type milling cutter Fresa a manicotto	d	d _A	b	A	B	K	p	z	Wendeschneidplatte Indexable insert Inserto
90S610.63-04N11	63	22	4	8	34	4	14	8	SNHX 1102T
90S610.63-05N11	63	22	5	8	34	4	14	8	SNHX 1103T
90S610.63-06N12	63	22	6	8	34	3	14	6	SNHX 1203T
90S610.80-04N11	80	22	4	8	34	5	22	10	SNHX 1102T
90S610.80-05N11	80	22	5	8	34	5	22	10	SNHX 1103T
90S610.80-06N12	80	22	6	8	34	4	22	8	SNHX 1203T
90S610.100-04N11	100	27	4	12	45	6	27	12	SNHX 1102T
90S610.100-05N11	100	27	5	12	45	6	27	12	SNHX 1103T
90S610.100-06N12	100	27	6	12	45	5	27	10	SNHX 1203T
90S610.100-10N12	100	27	10	12	45	5	27	10	SNHX 1205T
90S610.125-04N11	125	40	4	12	58	6	33	12	SNHX 1102T
90S610.125-05N11	125	40	5	12	58	6	33	12	SNHX 1103T
90S610.125-06N12	125	40	6	12	58	6	33	12	SNHX 1203T
90S610.125-10N12	125	40	10	12	58	6	33	12	SNHX 1205T
90S610.160-04N11	160	40	4	12	68	9	45	18	SNHX 1102T
90S610.160-05N11	160	40	5	12	68	9	45	18	SNHX 1103T
90S610.160-06N12	160	40	6	12	68	8	45	16	SNHX 1203T
90S610.160-10N12	160	40	10	12	68	8	45	16	SNHX 1205T
90S610.160-14N12	160	40	14	14	68	5	45	15	SNHX 1205T
90S610.200-04N11	200	50	4	12	72	9	63	18	SNHX 1102T
90S610.200-05N11	200	50	5	12	72	9	63	18	SNHX 1103T
90S610.200-06N12	200	50	6	12	72	9	63	18	SNHX 1203T
90S610.200-10N12	200	50	10	12	72	9	63	18	SNHX 1205T
90S610.200-14N12	200	50	14	14	72	6	63	18	SNHX 1205T
90S610.250-10N12	250	50	10	12	72	12	88	24	SNHX 1205T

K = Vorschubfaktor
 K = Forward feed factor
 K = Fattore d'avanzamento

z = Anzahl Wendeschneidplatten
 z = Number of inserts
 z = Numero di inserti

90S610. ..N..

Ersatzteile / Spare parts / Ricambi

Bezeichnung Designation Articolo	Spannschraube Screw Vite	Schraubendreher Screw driver Chiave
90S610.63-04N11	VTX 3503	T 5109
90S610.63-05N11	VTX 3504	T 5109
90S610.63-06N12	VTX 405	T 5115
90S610.80-04N11	VTX 3503	T 5109
90S610.80-05N11	VTX 3504	T 5109
90S610.80-06N12	VTX 405	T 5115
90S610.100-04N11	VTX 3503	T 5109
90S610.100-05N11	VTX 3504	T 5109
90S610.100-06N12	VTX 405	T 5115
90S610.100-10N12	VTX 408	T 5115
90S610.125-04N11	VTX 3503	T 5109
90S610.125-05N11	VTX 3504	T 5109
90S610.125-06N12	VTX 405	T 5115
90S610.125-10N12	VTX 408	T 5115
90S610.160-04N11	VTX 3503	T 5109
90S610.160-05N11	VTX 3504	T 5109
90S610.160-06N12	VTX 405	T 5115
90S610.160-10N12	VTX 408	T 5115
90S610.160-14N12	VTX 408	T 5115
90S610.200-04N11	VTX 3503	T 5109
90S610.200-05N11	VTX 3504	T 5109
90S610.200-06N12	VTX 405	T 5115
90S610.200-10N12	VTX 408	T 5115
90S610.200-14N12	VTX 408	T 5115
90S610.250-10N12	VTX 408	T 5115

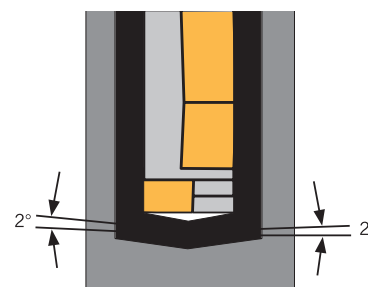

Grund ist nicht eben (2°)!
 Bottom is not flat (2°)!
 La base non è piana (2°)!



90S610M. ..N..

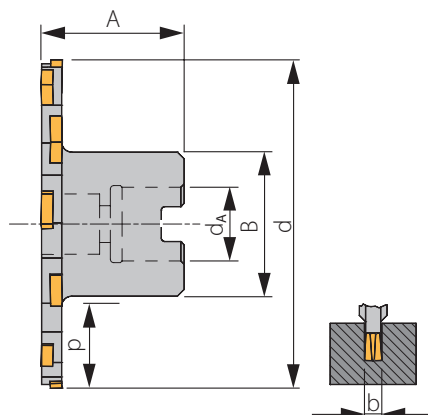
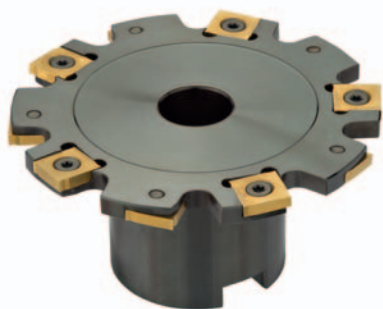

Scheiben- und Trennfräser
 Side and face milling cutter
 Frese per scanalature e taglio

Rechte Ausführung abgebildet
 Right-hand execution shown
 Versione destra in figura

4

Aufsteckfräser Shell type milling cutter Fresa a manicotto	d	d _A	b	A	B	K	p	z	Wendeschneidplatte Indexable insert Inserto
90S610M.63-04N11	63	22	4	50	40	4	10,5	8	SNHX 1102T
90S610M.63-05N11	63	22	5	50	40	4	10,5	8	SNHX 1103T
90S610M.63-06N12	63	22	6	50	40	3	10,5	6	SNHX 1203T
90S610M.80-04N11	80	22	4	50	40	5	20,2	10	SNHX 1102T
90S610M.80-05N11	80	22	5	50	40	5	20,2	10	SNHX 1103T
90S610M.80-06N12	80	22	6	50	40	4	20,2	8	SNHX 1203T
90S610M.100-04N11	100	27	4	50	48	6	24,2	12	SNHX 1102T
90S610M.100-05N11	100	27	5	50	48	6	24,2	12	SNHX 1103T
90S610M.100-06N12	100	27	6	50	48	5	24,2	10	SNHX 1203T
90S610M.100-10N12	100	27	10	50	48	5	24,2	10	SNHX 1205T
90S610M.125-06N12	125	40	6	50	70	6	23,7	12	SNHX 1203T
90S610M.125-10N12	125	40	10	50	70	6	23,7	12	SNHX 1205T
90S610M.160-06N12	160	40	6	50	70	8	41,2	16	SNHX 1203T
90S610M.160-10N12	160	40	10	50	70	8	41,2	16	SNHX 1205T

K = Vorschubfaktor
 K = Forward feed factor
 K = Fattore d'avanzamento

z = Anzahl Wendeschneidplatten
 z = Number of inserts
 z = Numero di inserti

Ersatzteile / Spare parts / Ricambi

Bezeichnung Designation Articolo	Spannschraube Screw Vite	Schraubendreher Screw driver Chiave
90S610M.63-04N11	VTX 3503	T 5109
90S610M.63-05N11	VTX 3504	T 5109
90S610M.63-06N12	VTX 405	T 5115
90S610M.80-04N11	VTX 3503	T 5109
90S610M.80-05N11	VTX 3504	T 5109
90S610M.80-06N12	VTX 405	T 5115
90S610M.100-04N11	VTX 3503	T 5109
90S610M.100-05N11	VTX 3504	T 5109
90S610M.100-06N12	VTX 405	T 5115
90S610M.100-10N12	VTX 408	T 5115
90S610M.125-06N12	VTX 405	T 5115
90S610M.125-10N12	VTX 408	T 5115
90S610M.160-06N12	VTX 405	T 5115
90S610M.160-10N12	VTX 408	T 5115

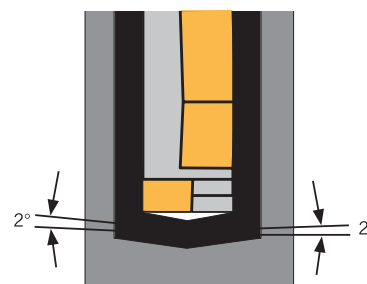

Grund ist nicht eben (2°)!
 Bottom is not flat (2°)!
 La base non è piana (2°)!

ACME90...

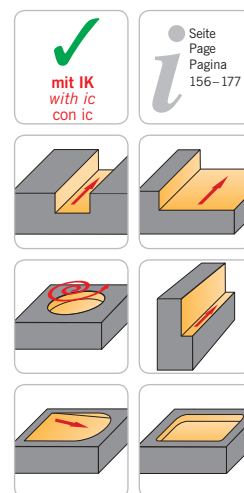
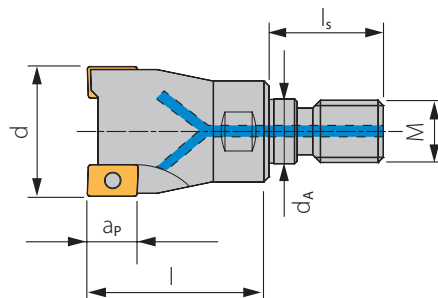

Rechte Ausführung abgebildet
 Right-hand execution shown
 Versione destra in figura

Einschraubfräser

Screw shank milling cutter

Fresa con attacco filettato

Schafffräser End mill Fresa cilindrica	d	a _p	l	d _A	M	z	l _s	Wendeschneidplatte Indexable insert Inserto
ACME90.01.10.P10	10	9	20	6,5	M6	1	14,5	AP.. 1003...
ACME90.01.12.P10	12	9	20	6,5	M6	1	14,5	AP.. 1003...
ACME90.02.16.P10	16	9	25	8,5	M8	2	17,5	AP.. 1003...
ACME90.03.20.P10	20	9	30	10,5	M10	3	20	AP.. 1003...
ACME90.03.25.P10	25	9	35	12,5	M12	3	22	AP.. 1003...
ACME90.04.25.P10	25	9	35	12,5	M12	4	22	AP.. 1003...
ACME90.05.32.P10	32	9	43	17	M16	5	24	AP.. 1003...
ACME90.03.32.P16	32	15	46	17	M16	3	24	AP.. 1604...
ACME90.04.40.P16	40	15	46	17	M16	4	24	AP.. 1604...

z = Anzahl Wendeschneidplatten
 z = Number of inserts
 z = Numero di inserti

Hinweis: Verlängerungen siehe Seite 153 – 154.
 Remark: For extensions refer to pages 153 – 154.
 Nota: per estensioni fare riferimento a pag. 153 – 154



Ersatzteile / Spare parts / Ricambi

Bezeichnung Designation Articolo	Spannschraube Screw Vite	Schraubendreher Screw driver Chiave
ACME90...10-25	SS 1225	T 5108
ACME90.05.32.P10	SS 1240	T 5115
ACME90.03.32.P10	SS 1240	T 5115
ACME90.04.40.P10	SS 1240	T 5115

ACME40...

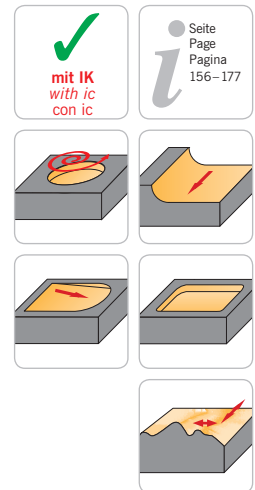
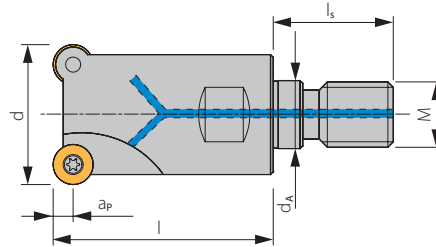

Einschraubfräser / Screw shank milling cutter / Fresa con attacco filettato

Rechte Ausführung abgebildet
 Right-hand execution shown
 Versione destra in figura

Rundfräser Circular milling Fresa filettata	d	l	M	d _A	l _s	a _p	z	Wendeschneidplatten Inserts Inserti
ACME40.02.10.D05	10	18	M6	6,5	14,5	2,5	2	RD.. 0501
ACME40.05.20.D05	20	30	M10	10,5	20,0	2,5	5	RD.. 0501
ACME40.02.12.D07	12	18	M6	6,5	14,5	3,5	2	RD.. 07T1
ACME40.02.15.D07	15	23	M8	8,5	17,5	3,5	2	RD.. 0702
ACME40.03.15.D07	15	23	M8	8,5	17,5	3,5	3	RD.. 0702
ACME40.04.20.D07	20	30	M10	10,5	20,0	3,5	4	RD.. 0702
ACME40.05.25.D07	25	35	M12	12,5	22,0	3,5	5	RD.. 0702
ACME40.05.30.D07	30	43	M16	17,0	24,0	3,5	5	RD.. 0702
ACME40.02.20.D10	20	30	M10	10,5	20,0	5,0	2	RD.. 1003
ACME40.02.25.D10	25	35	M12	12,5	22,0	5,0	2	RD.. 1003
ACME40.03.25.D10	25	35	M12	12,5	22,0	5,0	3	RD.. 1003
ACME40.04.30.D10	30	43	M16	17,0	24,0	5,0	4	RD.. 1003
ACME40.04.35.D10	35	43	M16	17,0	24,0	5,0	4	RD.. 1003
ACME40.05.42.D10	42	43	M16	17,0	24,0	5,0	5	RD.. 1003
ACME40.02.24.D12	24	35	M12	12,5	22,0	6,0	2	RD.. 12T3
ACME40.03.35.D12	35	43	M16	17,0	24,0	6,0	3	RD.. 12T3
ACME40.04.42.D12	42	43	M16	17,0	24,0	6,0	4	RD.. 12T3
ACME40.02.32.D16	32	43	M16	17,0	24,0	8,0	2	RD.. 1604

Ersatzteile / Spare parts / Ricambi

Bezeichnung Designation Articolo	Spannschraube Screw Vite	Spannklaue Clamp Staffa	Klemmschraube Clamping screw Vite	Schraubendreher Screw driver Chiave
ACME40.02.10.D05	SS 1218	-	-	T 5106
ACME40.05.20.D05	SS 1218	-	-	T 5106
ACME40.02.12.D07	SS 2530	-	-	T 5107
ACME40.02.15.D07	SS 2530	-	-	T 5107
ACME40.03.15.D07	SS 2530	-	-	T 5107
ACME40.04.20.D07	SS 2530	-	-	T 5107
ACME40.05.25.D07	SS 2530	-	-	T 5107
ACME40.05.30.D07	SS 2530	-	-	T 5107
ACME40.02.20.D10	SS 3500	-	-	T 5115
ACME40.02.25.D10	SS 3500	-	-	T 5115
ACME40.03.25.D10	SS 3500	-	-	T 5115
ACME40.04.30.D10	SS 3500	-	-	T 5115
ACME40.04.35.D10	SS 3500	-	-	T 5115
ACME40.05.42.D10	SS 3500	-	-	T 5115
ACME40.02.24.D12	SS 3500	-	CVB 35	T 5115
ACME40.03.35.D12	SS 3500	-	CVB 35	T 5115
ACME40.04.42.D12	SS 3500	-	CVB 35	T 5115
ACME40.02.32.D16	SS 4500	CVB 45	-	T 5115

Hinweis: Verlängerungen
 siehe Seite 153 – 154.
 Remark: For extensions refer
 to pages 153 – 154.
 Nota: per estensioni fare
 riferimento a pag. 153 – 154

z = Anzahl Wendeschneidplatten
 z = Number of inserts
 z = Numero di inserti

ACMA40...

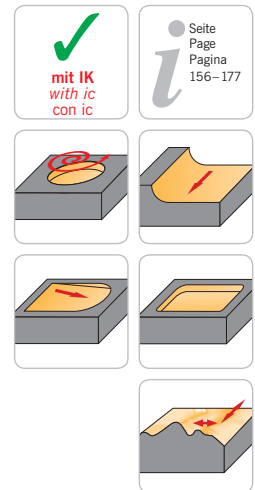
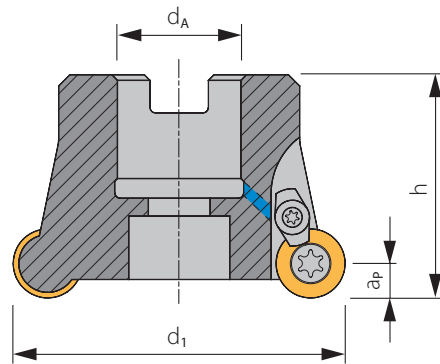

Rechte Ausführung abgebildet
 Right-hand execution shown
 Versione destra in figura

Planfräser / Face milling cutter / Frese per spianatura

Rundfräser Circular milling Fresa a manicotto	d_1	d_A	d_2	h	a_p	z	Wendeschneidplatte Indexable insert Inserto
ACMA40.04.042.D10	42	16	-	44	5	6	RD.. 1003
ACMA40.05.052.D12	52	22	-	50	6	5	RD.. 12T3
ACMA40.04.052.D16	52	22	-	50	8	4	RD.. 1604
ACMA40.06.066.D12	66	27	-	50	6	6	RD.. 12T3
ACMA40.05.066.D16	66	27	-	50	8	5	RD.. 1604
ACMA40.07.080.D12	80	27	-	50	6	7	RD.. 12T3
ACMA40.06.080.D16	80	27	-	50	8	6	RD.. 1604
ACMA40.07.100.D16	100	32	-	55	8	7	RD.. 1604
ACMA40.08.125.D16	125	40	-	55	8	8	RD.. 1604
ACMA40.09.160.D16	160	40	66,7	55	8	9	RD.. 1604

d_2 = Lochabstand Befestigungsschrauben für Fräsdorn
 d_2 = Hole distance locking screw for milling arbor
 d_2 = interasse fori viti bloccaggio fresa

z = Anzahl Wendeschneidplatten
 z = Number of inserts
 z = Numero di inserti

Ersatzteile / Spare parts / Ricambi

Bezeichnung Designation Articolo	Spannschraube Screw Vite	Spannklaue Clamp Staffa	Klemmschraube Clamping screw Vite	Schraubendreher Screw driver Chiave
ACMA40.04.042.D10	SS 3500	-	-	T 5115
ACMA40.05.052.D12	SS 3500	-	CVB 35	T 5115
ACMA40.04.052.D16	SS 4500	CVB 45	-	T 5120
ACMA40.06.066.D12	SS 3500	-	CVB 35	T 5115
ACMA40.05.066.D16	SS 4500	CVB 45	-	T 5120
ACMA40.07.080.D12	SS 3500	-	CVB 35	T 5115
ACMA40.06.080.D16	SS 4500	CVB 45	-	T 5120
ACMA40.07.100.D16	SS 4500	CVB 45	-	T 5120
ACMA40.08.125.D16	SS 4500	CVB 45	-	T 5120
ACMA40.09.160.D16	SS 4500	CVB 45	-	T 5120

AF45...

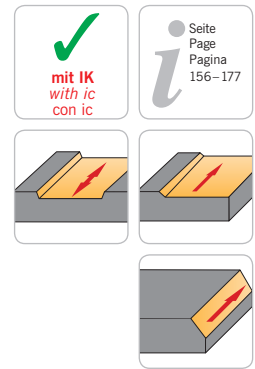
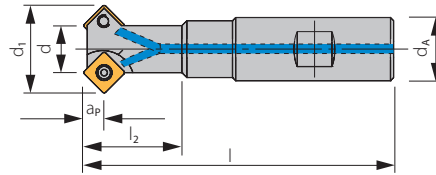

Fasfräser / Chamfering cutter / Frese per smussi - 45°

Rechte Ausführung abgebildet
 Right-hand execution shown
 Versione destra in figura

Fasfräser Chamfering cutter Frese per smussi	d	d ₁	l	l ₂	d _A	z	a _p **	Wendeschneidplatte Indexable insert Inserto
AF45-10/4 C06	4	10	80	28	12	1	4,3	SC.. 0602...
AF45-20/11 C06	11	20	80	32	12	2	4,3	SC.. 0602...
AF45-24/12 C09	12	23,7	100	37	20	1	6,6	SC.. 09T3...
AF45-29/16 C09	16	28,8	100	32	16	2	6,6	SC.. 09T3...
AF45-42/30 C09	30	42,3	100	32	20	3	6,6	SC.. 09T3...
AF45-24/12L C09 *	12	23,7	200	37	20	1	6,6	SC.. 09T3...
AF45-29/16L C09 *	16	28,8	200	32	16	2	6,6	SC.. 09T3...
AF45-42/30L C09 *	30	42,3	200	32	20	3	6,6	SC.. 09T3...

* Fasfräser – lange Ausführung
* Chamfering cutter – long type
* Frese per smussi – tipo lungo

** Maß „a“ bezieht sich auf Wendeschneidplatten mit Radius 0,2 mm
** Dimension „a“ refers to indexable insert with corner radius 0,2 mm
** La misura „a“ si riferisce ad inserti con raggio 0,2 mm

z = Anzahl Wendeschneidplatten
z = Number of inserts
z = Numero di inserti

Ersatzteile / Spare parts / Ricambi

Bezeichnung Designation Articolo	Spannschraube Screw Vite	Schraubendreher Screw driver Chiave
AF45-10 - 20 ...	SS 1225	T 5106
AF45-24 - 42 ...	SS 1240	T 5115

AFS45. ...C16

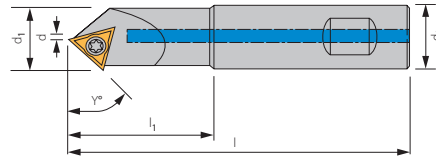
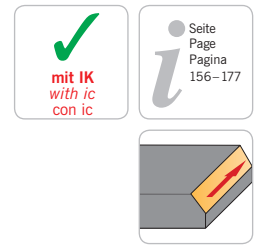

Fasfräser / Chamfering cutter / Frese per smussi - 45°

Rechte Ausführung abgebildet
 Right-hand execution shown
 Versione destra in figura

Fasfräser Chamfering cutter Frese per smussi	l	l ₁	d _a	y°	z	D _{min}	D _{max}	Wendeschneidplatte Indexable insert Inserto
AFS45-20/115-C16	115	40	20	45°	1	0,2	20	TCMT 16T3...
AFS45-20/150-C16	150	60	20	45°	1	0,2	20	TCMT 16T3...
AFS45-20/200-C16	200	80	20	45°	1	0,2	20	TCMT 16T3...

z = Anzahl Wendeschneidplatten
 z = Number of inserts
 z = Numero di inserti



Ersatzteile / Spare parts / Ricambi

Bezeichnung Designation Articolo	Spannschraube Screw Vite	Schraubendreher Screw driver Chiave
AFS45. ...C16	SS 1240	T 5115

AFS ..C11/C16

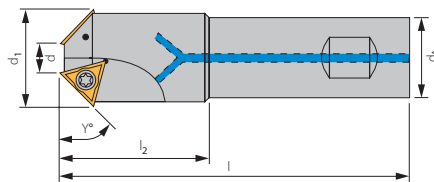

Fasfräser / Chamfering cutter / Frese per smussi – 30° / 45° / 60°

Rechte Ausführung abgebildet
 Right-hand execution shown
 Versione destra in figura

Fasfräser Chamfering cutter Frese per smussi	d	d ₁	l	l ₂	d _A	y°	z	Wendeschneidplatte Indexable insert Inserto
AFS30-32/6 C16	6,0	32,0	100	38	25	30°	2	TCMT 16T3...
AFS45-16/1 C11	1,2	16,0	70	20	12	45°	1	TCMT 1102...
AFS45-21/6 C11	6,2	21,0	90	35	20	45°	2	TCMT 1102...
AFS45-32/10 C16	10,4	32,5	100	42	25	45°	2	TCMT 16T3...
AFS60-16/5 C11	5,4	16,0	70	20	12	60°	1	TCMT 1102...
AFS60-26/16 C11	15,8	26,0	90	35	20	60°	2	TCMT 1102...
AFS60-35/20 C16	20,0	35,0	100	39	25	60°	2	TCMT 16T3...

z = Anzahl Wendeschneidplatten
 z = Number of inserts
 z = Numero di inserti

4

Ersatzteile / Spare parts / Ricambi

Bezeichnung Designation Articolo	Spannschraube Screw Vite	Schraubendreher Screw driver Chiave
AFS30. ..C16	SS 1240	T 5115
AFS45. ..C11	SS 1225	T 5108
AFS45. ..C16	SS 1240	T 5115
AFS60. ..C11	SS 1225	T 5108
AFS60. ..C16	SS 1240	T 5115

AFS45. ..T16

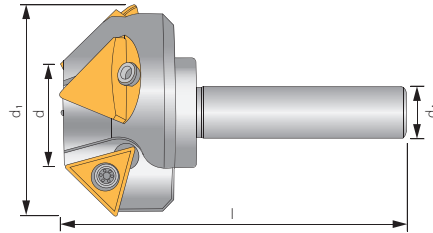
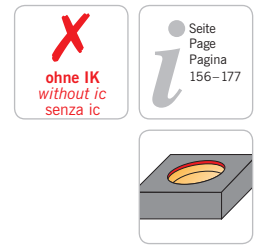

Entgratsenker / Deburring cutter / Frese a smussare – 45°

Rechte Ausführung abgebildet
 Right-hand execution shown
 Versione destra in figura

Fasfräser Chamfering cutter Frese per smussi	d	d ₁	l	d _A	y°	z	Wendeschneidplatte Indexable insert Inserto
AFS45-25/5 T16	5	25	78	12	45°	1	TCGX 163504...
AFS45-45/25 T16	25	45	78	12	45°	1	TCGX 163504...

z = Anzahl Wendeschneidplatten
 z = Number of inserts
 z = Numero di inserti



Ersatzteile / Spare parts / Ricambi

Bezeichnung Designation Articolo	Spannschraube Screw Vite	Schraubendreher Screw driver Chiave
AFS45. ..T16	SS 1240	T 5115

45FS-440V. .. C12

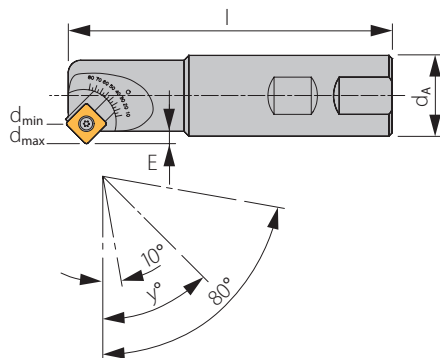

Fasfräser, einstellbar – 10° - 80°

Chamfering milling cutter with adjustable angle – 10° - 80°

Frese per smussi e svasature registrabile – 10° - 80°

Rechte Ausführung abgebildet
Right-hand execution shown
Versione destra in figura

Fasfräser Chamfering cutter Frese per smussi	d _A	l	y°	E	Wendeschneidplatte Indexable insert Inserto
45FS-440V-020 C12	20	100	10°-80°	2,7-4,6	SC.. 1204... / TC.. 16T3...
45FS-440V-025 C12	25	100	10°-80°	2,7-4,6	SC.. 1204... / TC.. 16T3...
45FS-440VL-025 C12	25	150	10°-80°	2,7-4,6	SC.. 1204... / TC.. 16T3...
45FS-440VXL-025 C12	25	200	10°-80°	2,7-4,6	SC.. 1204... / TC.. 16T3...

4

Verstellbereich für Fasfräser

Adjusting area for chamfering milling cutter

Area di utilizzo per frese per smussi e svasature

Hinweis: Fräser werden mit 2 Kassetten ausgeliefert (T16 + S12)
Remark: Milling cutters are included 2 pockets (T16 + S12)
Nota: Frese vengono fornite con 2 cassette comprese (T16 + S12)

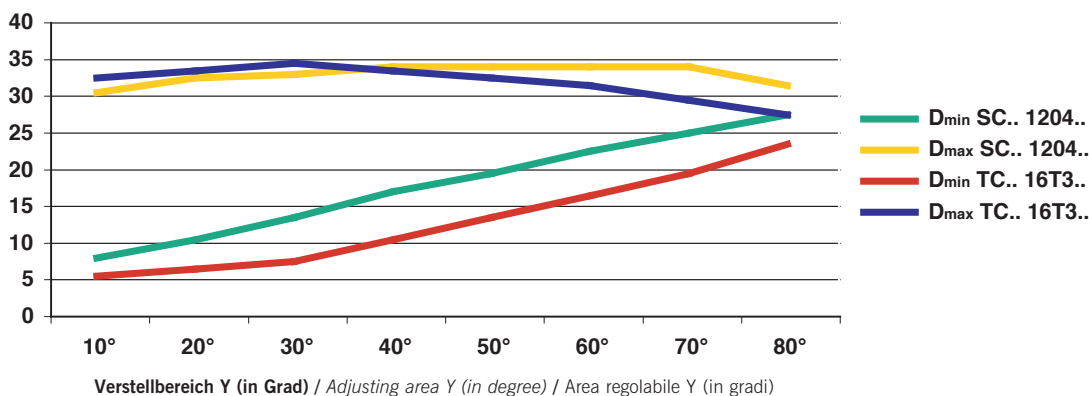

Ersatzteile für Plattensitz SC..1204.. / Spare parts for insert seat SC..1204.. / Ricambi per ravnicinato SC..1204..

Für Fasfräser For chamfering milling cutter Per frese per smussi	Spannschraube WSP Screw insert Vite inserto	Schraubendreher Screw driver Chiave	Plattensitz (schwenkbar) Adjustable insert seat Cartuccia registrabile	Klemmschraube Plattensitz Fixing screw for seat Vite cartuccia
45FS-440V...-.../.. C12	SS 1290 S	KS 1115	S12N	V 1006

Ersatzteile für Plattensitz TC..16T3.. / Spare parts for insert seat TC..16T3.. / Ricambi per ravnicinato TC..16T3..

Für Fasfräser For chamfering milling cutter Per frese per smussi	Spannschraube WSP Screw insert Vite inserto	Schraubendreher Screw driver Chiave	Plattensitz (schwenkbar) Adjustable insert seat Cartuccia registrabile	Klemmschraube Plattensitz Fixing screw for seat Vite cartuccia
45FS-440V...-.../.. C12	SS 1240	KS 1115	T16N	V 1006

AFA...-P10

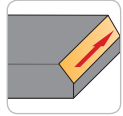
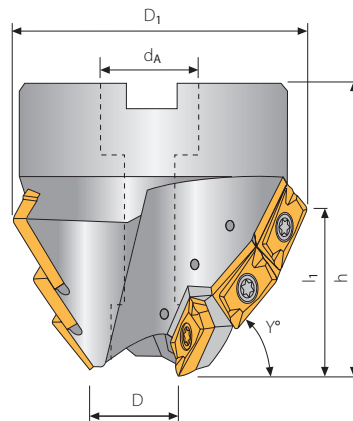

Fasfräser / Chamfering cutter / Frese per smussi

Rechte Ausführung abgebildet
 Right-hand execution shown
 Versione destra in figura

Aufsteckfräser Shell type milling cutter Fresa a manicotto	D	D ₁	d _A	h	y°	l ₁	K	z	Wendeschneidplatte Indexable insert Inserto
AFA15-70/17-P10	17	70	22	50	15°	7	3	9	AP.. 1003...
AFA30-65/17-P10	17	65	22	50	30°	13	3	9	AP.. 1003...
AFA40-60/17-P10	17	60	22	50	40°	17	3	9	AP.. 1003...
AFA45-56/17-P10	17	56	22	50	45°	19	3	9	AP.. 1003...
AFA60-45/17-P10	17	45	16	50	60°	24	3	9	AP.. 1003...
AFA75-33/19-P10	19	33	16	60	75°	27	3	9	AP.. 1003...

K = Vorschubfaktor
K = Forward feed factor
K = Fattore d'avanzamento

z = Anzahl Wendeschneidplatten
z = Number of inserts
z = Numero di inserti

Ersatzteile / Spare parts / Ricambi

Bezeichnung Designation Articolo	Spannschraube Screw Vite	Schraubendreher Screw driver Chiave
AFA...-P10	SS 1225	T 5108

4

AFA...-P16

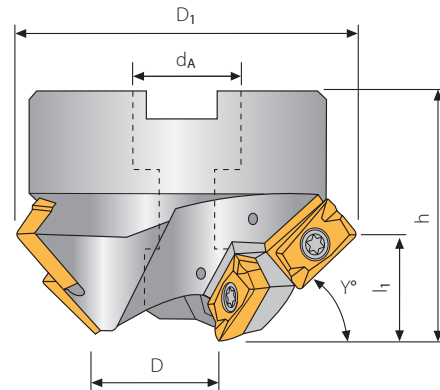
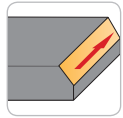

Fasfräser / Chamfering cutter / Frese per smussi

Rechte Ausführung abgebildet
 Right-hand execution shown
 Versione destra in figura

Aufsteckfräser Shell type milling cutter Fresa a manicotto	D	D ₁	d _A	h	y°	l ₁	K	z	Wendeschneidplatten Inserts Inserti
AFA15-94/35-P16	35	94,0	27	50	15°	8,0	3	6	AP.. 1604...
AFA30-88/35-P16	35	88,0	27	50	30°	15,0	3	6	AP.. 1604...
AFA40-84/35-P16	35	84,0	27	50	40°	19,0	3	6	AP.. 1604...
AFA45-77/35-P16	35	77,8	27	50	45°	21,5	3	6	AP.. 1604...
AFA60-65/35-P16	35	65,0	27	50	60°	26,5	3	6	AP.. 1604...
AFA75-50/35-P16	35	50,7	22	60	75°	29,5	3	6	AP.. 1604...

K = Vorschubfaktor
 K = Forward feed factor
 K = Fattore d'avanzamento

z = Anzahl Wendeschneidplatten
 z = Number of inserts
 z = Numero di inserti

4

Ersatzteile / Spare parts / Ricambi

Bezeichnung Designation Articolo	Spannschraube Screw Vite	Schraubendreher Screw driver Chiave
AFA...-P16	SS 1240	T 5115

T-976W-..P..

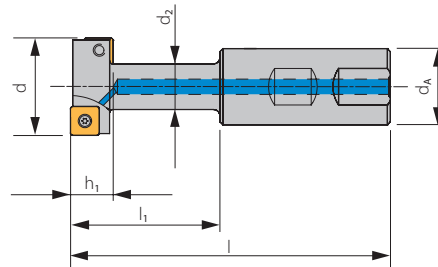

Fräser für T-Nuten / T-slot milling cutter / Frese per cave a T

Rechte Ausführung abgebildet
Right-hand execution shown
Versione destra in figura

Schafffräser Cylindrical end mill shank Fresa a T	d	d ₂	l	l ₁	h ₁	d _A	K	z	Wendeschneidplatte Indexable insert Inserto
T-976W-21P06	21	11	76	26	9	16	1	2	SPMT 060304...
T-976W-25P06	25	13	82	31	11	16	2	4	SPMT 060304...
T-976W-32P09	32	17	88	38	14	20	2	4	SPMT 09T308...
T-976W-40P09	40	21	108	50	17	25	2	4	SPMT 09T308...
T-976W-50P12	50	27	120	56	22	32	2	4	SPMT 120408...

Hinweis: Für „T“ Nuten nach DIN 650 – ISO 299 Normen.
Remark: For „T“ slot as of DIN 650 – ISO 299 standard.
Nota: Per cave a „T“ secondo norme DIN 650 – ISO 299.

K = Vorschubfaktor
K = Forward feed factor
K = Fattore d' avanzamento

z = Anzahl Wendeschneidplatten
z = Number of inserts
z = Numero di inserti



Ersatzteile / Spare parts / Ricambi

Bezeichnung Designation Articolo	Spannschraube Screw Vite	Schraubendreher Screw driver Chiave
T-976W-..P06	SS 1225	T 5108
T-976W-..P09	SS 3500	T 5115
T-976W-..P12	SS 5000	T 5120

Fräsen von genormten T-Nuten

Milling of standard T-slots

Fresatura di cave a T

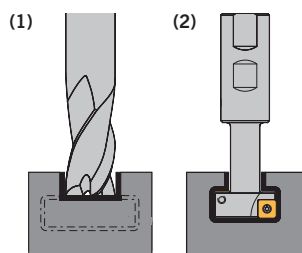

Hinweis: Um eine optimale Lebensdauer des T-Nutenfräasers zu erreichen, sollte beim Vorfräsen mit dem Schafffräser (Bild 1) die Mindestfrästiefe von ca. 1 mm unterhalb des Nuthalses nicht überschritten werden.

Information: Information: In order to achieve optimum tool life, the pre-milling (with an end mill – picture 1) should not be more than 1mm below the neck.

Nota: per raggiungere una durata di vita ottimale della fresa per cave a T, nella fase di prefresatura con fresa (immagine 1) non bisogna superare la profondità di fresatura minima di c.ca 1 mm sotto il collo della scanalatura.

Erweiterte Anwendungsmöglichkeiten

Additional application possibilities
Possibilità ulteriori di applicazione

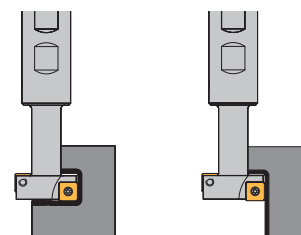

- 1) Vorfräsen mit Schafffräser / Pre-milling with end mill / Pre-fresatura con fresa
- 2) Fertigfräsen T-Nut T-976W / Milling with T-slot cutter T-976W / Fresatura con fresa per cave a T-976W

Der Einsatz von Druckluft oder ausreichend Kühlung ist absolut notwendig, um eine einwandfreie Spanabfuhr zu erreichen.

Air cooling or sufficient cooling is necessary to achieve optimum chip flow.

L'impiego di aria compressa o sufficiente raffreddamento è assolutamente necessario per raggiungere una ottimale evacuazione del truciolo.

72ES. ...P..

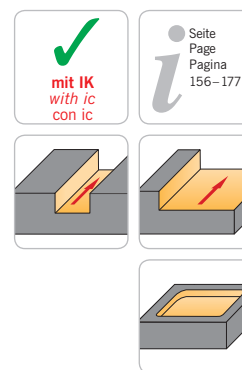
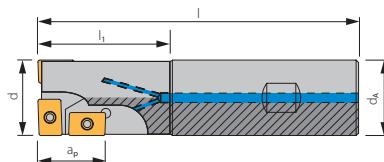

Bohrnutfräser / Drill and slotting cutter / Frese foranti

Rechte Ausführung abgebildet
 Right-hand execution shown
 Versione destra in figura

Schafffräser End mill Fresa cilindrica	d	d _a	l	l ₁	a _p	K	z	Wendeschneidplatte Indexable insert Inserto
72ES.020R.P10	20	20	90	35	17	2	3	AP.. 1003...
72ES.025R.P10	25	25	110	50	19	2	3	AP.. 1003...
72ES.032R.P16	32	32	130	50	30	2	3	AP.. 1604...
72ESL.020R.P10	20	20	150	30	17	2	3	AP.. 1003...
72ESL.025R.P10	25	25	150	50	19	2	3	AP.. 1003...
72ESXL.020R.P10	20	20	180	30	17	2	3	AP.. 1003...
72ESXL.025R.P10	25	25	200	50	19	2	3	AP.. 1003...
72ESXL.032R.P16	32	32	220	50	30	2	3	AP.. 1604...

K = Vorschubfaktor
 K = Forward feed factor
 K = Fattore d'avanzamento

z = Anzahl Wendeschneidplatten
 z = Number of inserts
 z = Numero di inserti

Ersatzteile / Spare parts / Ricambi

Bezeichnung Designation Articolo	Spannschraube Screw Vite	Schraubendreher Screw driver Chiave
72ES. ...R.P10	SS 1225	T 5108
72ES. ...R.P16	SS 1240	T 5115

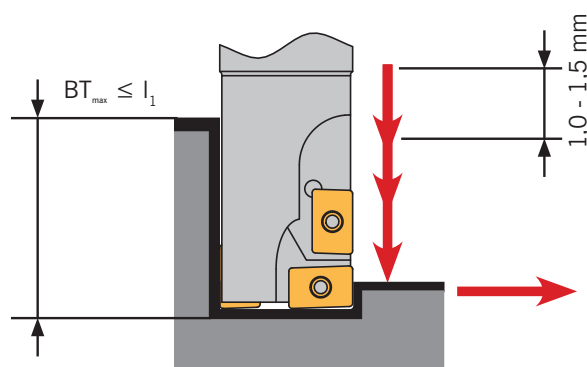

Hinweis: Bei langspanenden Werkstoffen wird ein Bohrintervall von 0,1–1,5 mm empfohlen!

Remark: When machining long-chipping materials a drilling interval of 0.1–1.5 mm is recommended!

Nota: in caso di materiali a truciolo lungo si raccomanda un intervallo di avanzamento in foratura di 0,1–1,5 mm!

ASF80...

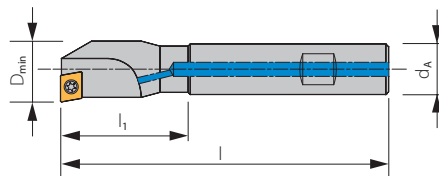
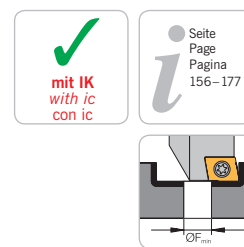

Senkungsfräser / Indentation milling cutter / Frese per lamatura

Rechte Ausführung abgebildet
 Right-hand execution shown
 Versione destra in figura

Senkungsfräser Indentation milling cutter Frese per lamatura	D _{min}	F _{min}	l ₁	l	d _A	z	Wendeschneidplatte Indexable insert Inserto
ASF80-012/D10	10	4	15	85	12	1	CC.. 0602...
ASF80-012/D11	11	4	15	85	12	1	CC.. 0602...
ASF80-012/D12	12	4	18	85	12	1	CC.. 0602...
ASF80-012/D13	13	5	23	85	12	1	CC.. 0602...
ASF80-012/D14	14	5	23	85	12	1	CC.. 0602...
ASF80-012/D15	15	5	30	85	12	1	CC.. 0602...
ASF80-012/D16	16	5	30	85	12	1	CC.. 0602...
ASF80-016/D17	17	6	30	95	16	1	CC.. 09T3...
ASF80-016/D18	18	6	40	95	16	1	CC.. 09T3...
ASF80-016/D19	19	6	40	95	16	1	CC.. 09T3...
ASF80-016/D20	20	5	40	95	16	1	CC.. 09T3...
ASF80-016/D21	21	5	42	95	16	1	CC.. 09T3...
ASF80-016/D22	22	6	42	95	16	1	CC.. 09T3...
ASF80-016/D23	23	6	42	95	16	1	CC.. 09T3...
ASF80-016/D24	24	6	42	95	16	1	CC.. 09T3...
ASF80-016/D25	25	8	42	95	16	1	CC.. 09T3...
ASF80-020/D26	26	8	56	120	20	1	CC.. 09T3...
ASF80-020/D27	27	8	56	120	20	1	CC.. 09T3...
ASF80-020/D28	28	10	56	120	20	1	CC.. 09T3...
ASF80-020/D29	29	10	56	120	20	1	CC.. 09T3...
ASF80-020/D30	30	10	56	120	20	1	CC.. 09T3...
ASF80-020/D31	31	12	56	120	20	1	CC.. 09T3...
ASF80-020/D32	32	12	56	120	20	1	CC.. 09T3...
ASF80-020/D33	33	12	56	120	20	1	CC.. 09T3...

F_{min} = Kleinster vorbearbeiteter Bohrungsdurchmesser
 F_{min} = Smallest pre-machined drilling diameter
 F_{min} = diametro di foro minimo prima della lavorazione

z = Anzahl Wendeschneidplatten
 z = Number of inserts
 z = Numero di inserti

Ersatzteile / Spare parts / Ricambi

Bezeichnung Designation Articolo	Spannschraube Screw Vite	Schraubendreher Screw driver Chiave
ASF80-..D10-16	SS 1225	T 5108
ASF80-..D17-33	SS 1240	T 5115

ASF90...

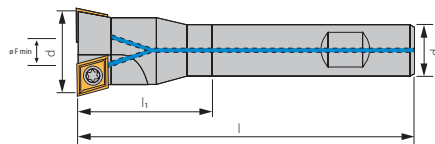
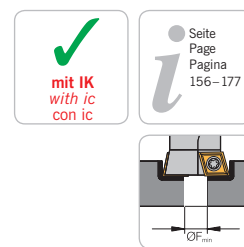

Senkungsfräser / Indentation milling cutter / Frese per lamatura

Rechte Ausführung abgebildet
 Right-hand execution shown
 Versione destra in figura

Senkungsfräser Indentation milling cutter Frese per lamatura	d	F _{min}	l ₁	l	d _A	z	Wendeschneidplatte Indexable insert Inserto
ASF90-012/D16	16	5	30	92	12	2	CC.. 0602...
ASF90-016/D17	17	6	32	94	16	2	CC.. 0602...
ASF90-016/D17,5	17,5	6,5	40	96	16	2	CC.. 0602...
ASF90-016/D18	18	7	41	97	16	2	CC.. 0602...
ASF90-016/D19	19	8	41	100	16	2	CC.. 0602...
ASF90-016/D20	20	9	41	102	16	2	CC.. 0602...
ASF90-016/D21	21	10	41	105	16	2	CC.. 0602...
ASF90-016/D22	22	11	41	110	16	2	CC.. 0602...
ASF90-016/D23	23	12	41	112	16	2	CC.. 0602...
ASF90-016/D24	24	13	41	115	16	2	CC.. 0602...
ASF90-016/D25	25	8	40	120	16	2	CC.. 09T3...
ASF90-020/D26	26	9	55	125	20	2	CC.. 09T3...
ASF90-020/D27	27	10	55	128	20	2	CC.. 09T3...
ASF90-020/D28	28	11	55	130	20	2	CC.. 09T3...
ASF90-020/D29	29	12	55	132	20	2	CC.. 09T3...
ASF90-020/D30	30	13	55	134	20	2	CC.. 09T3...
ASF90-020/D31	31	14	55	136	20	2	CC.. 09T3...
ASF90-020/D32	32	15	55	138	20	2	CC.. 09T3...
ASF90-020/D33	33	16	55	140	20	2	CC.. 09T3...
ASF90-025/D34	34	16	60	140	25	2	CC.. 09T3...
ASF90-025/D35	35	17	60	140	25	2	CC.. 09T3...
ASF90-025/D36	36	18	60	140	25	2	CC.. 09T3...
ASF90-025/D37	37	19	60	140	25	2	CC.. 09T3...
ASF90-025/D38	38	20	60	140	25	2	CC.. 09T3...
ASF90-025/D39	39	21	60	140	25	2	CC.. 09T3...
ASF90-025/D40	40	22	60	140	25	2	CC.. 09T3...
ASF90-025/D41	41	23	60	140	25	2	CC.. 09T3...
ASF90-025/D42	42	24	60	140	25	2	CC.. 09T3...

F_{min} = Kleinster vorbearbeiteter Bohrungsdurchmesser
 F_{min} = Smallest pre-machined drilling diameter
 F_{min} = diametro di foro minimo prima della lavorazione

z = Anzahl Wendeschneidplatten
 z = Number of inserts
 z = Numero di inserti

Ersatzteile / Spare parts / Ricambi

Bezeichnung Designation Articolo	Spannschraube Screw Vite	Schraubendreher Screw driver Chiave
ASF90-..D16-24	SS 1225	T 5108
ASF90-..D25-42	SS 1240	T 5115

AFB90-...-C..

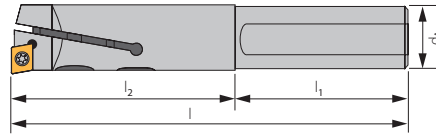
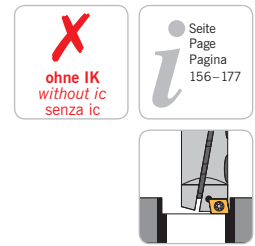

Einstellbare Feinbohrstangen
 Adjustable fine boring bars
 Barenı registrabili per alesatura

Rechte Ausführung abgebildet
 Right-hand execution shown
 Versione destra in figura

Schafffräser End mill Bareno registrabile	l	l ₁	l ₂	d _A	D _{min}	D _{max}	Wendeschneidplatte Indexable insert Inserto
AFB90-10/12-C06	100	70	30	10	10	12	CC.. 0602...
AFB90-12/15-C06	105	70	30	12	12	15	CC.. 0602...
AFB90-15/20-C06	110	60	50	16	16	20	CC.. 0602...
AFB90-20/25-C06	120	60	60	20	20	25	CC.. 0602...
AFB90-25/30-C09	140	70	70	25	25	30	CC.. 09T3...
AFB90-30/35-C09	160	70	90	25	30	35	CC.. 09T3...
AFB90-35/40-C09	170	70	100	32	35	40	CC.. 09T3...
AFB90-40/45-C09	190	70	120	32	40	45	CC.. 09T3...
AFB90-45/50-C09	220	70	150	32	45	50	CC.. 09T3...

4

Ersatzteile / Spare parts / Ricambi

Bezeichnung Designation Articolo	Spannschraube Screw Vite	Schraubendreher Screw driver Chiave	Zugschraube Adjust. screw Vite regolazione	Druckschraube Clamp screw Vite fissaggio
AFB90-10/12-C06	SS 1225	T 5108	RE 1	BL 0
AFB90-12/15-C06	SS 1225	T 5108	RE 1	BL 1
AFB90-15/20-C06	SS 1225	T 5108	RE 2	BL 2
AFB90-20/25-C06	SS 1225	T 5108	RE 3	BL 3
AFB90-25/30-C09	SS 1240	T 5115	RE 4	BL 4
AFB90-30/35-C09	SS 1240	T 5115	RE 5	BL 5
AFB90-35/40-C09	SS 1240	T 5115	RE 6	BL 6
AFB90-40/45-C09	SS 1240	T 5115	RE 7	BL 7
AFB90-45/50-C09	SS 1240	T 5115	RE 8	BL 10

ARS180-D..

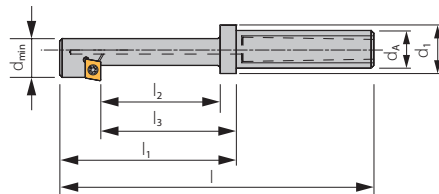
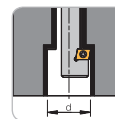

Rückwärtssenker / Back facing milling cutter / Frese per lamatura a tirare

Rechte Ausführung abgebildet
 Right-hand execution shown
 Versione destra in figura

Rückwärtssenker 180° Back facing milling cutter 180° Frese per lamatura a tirare 180°	d	D _{min}	l	l ₁	l ₂	l ₃	d _A	d ₁	e	Wendeschneidplatte Indexable insert Inserto
ARS180-D15*	15	8,5	105	55	35	42	20	25	3,5	CPMT 05T104
ARS180-D18*	18	10,5	112	62	40	47	20	25	4,0	CCMT 060204
ARS180-D20	20	13,0	117	167	45	52	20	25	3,75	CCMT 060204
ARS180-D24	24	15,0	122	172	50	57	20	25	4,75	CCMT 060204
ARS180-D26	26	17,0	132	182	60	67	20	25	5,00	CCMT 060204
ARS180-D30	30	19,0	142	192	65	77	20	25	6,00	CCMT 060204
ARS180-D33	33	21,0	152	102	75	82	20	25	6,50	CCMT 09T304
ARS180-D36	36	23,0	173	113	85	93	32	40	7,00	CCMT 09T304
ARS180-D40	40	25,0	183	123	95	103	32	40	8,00	CCMT 09T304
ARS180-D43	43	30,0	183	123	95	103	32	40	7,00	CCMT 09T304
ARS180-D48	48	33,0	223	163	135	143	32	40	8,00	CCMT 09T304
ARS180-D53	53	36,0	210	140	110	40	40	/	9,00	CCMT 120404
ARS180-D57	57	39,0	220	150	120	40	40	/	9,50	CCMT 120404
ARS180-D66	66	45,0	245	165	135	50	50	/	11,00	CCMT 120404
ARS180-D76	76	52,0	265	185	155	50	50	/	12,50	CCMT 120404

* ohne Innenkühlung
* without internal coolant
* senza adduzione interna

Ersatzteile / Spare parts / Ricambi

Bezeichnung Designation Articolo	Spannschraube Screw Vite	Schraubendreher Screw driver Chiave
ARS180-D15	T 2,2.04	T 5107
ARS180-D18-30	SS 1225	T 5108
ARS180-D33-48	SS 1240	T 5115
ARS180-D53-76	SS 5000	T 5120

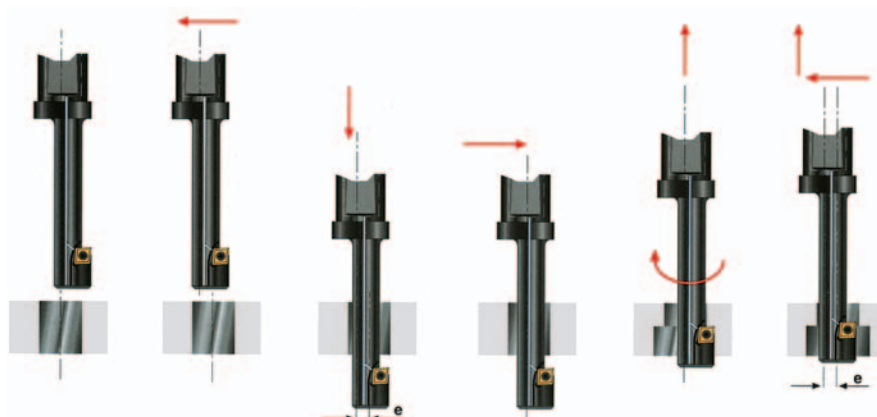
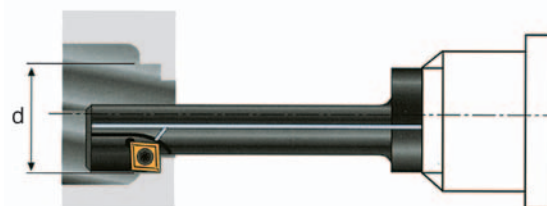

ACV1...

Seite
Page
Pagina
156-177

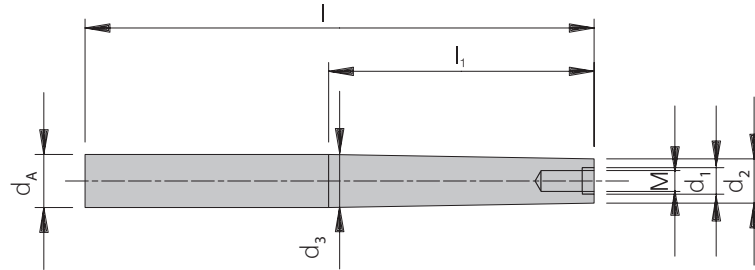

Stahlverlängerungen – konisch

Steel extensions – conical

Prolunghe in acciaio – forma conica

Stahlverlängerungen – konisch Steel extensions – conical Prolunghe in acciaio – forma conica	d_A	M	d_1	d_2	d_3	l_1	l
ACV1.25.025.21M12	25	M12	12,5	21	25	25	81
ACV1.25.040.23M12	25	M12	12,5	23	25	40	101
ACV1.25.075.21M12	25	M12	12,5	21	25	75	131
ACV1.25.109.23M12	25	M12	12,5	23	25	109	170
ACV1.25.125.21M12	25	M12	12,5	21	25	125	181
ACV1.32.105.23M12	32	M12	12,5	23	25	105	170
ACV1.32.025.29M16	32	M16	17	29	32	25	85
ACV1.32.040.30M16	32	M16	17	30	32	40	105
ACV1.32.075.29M16	32	M16	17	29	32	75	135
ACV1.32.125.29M16	32	M16	17	29	32	125	185

4

ACV2...

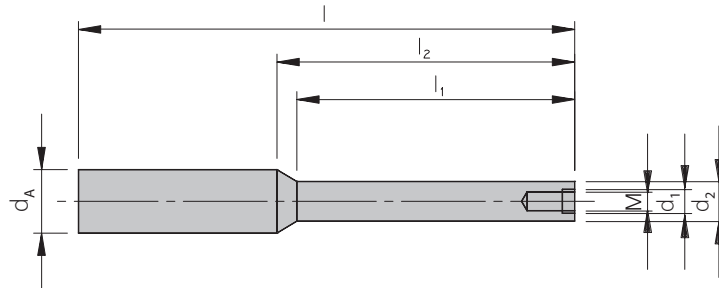

Stahlverlängerungen – zylindrisch

Steel extensions – cylindrical

Prolunghe in acciaio – forma cilindrica

Stahlverlängerungen – zylindrisch Steel extensions – cylindrical Prolunghe in acciaio – forma cilindrica	d_A	M	d_1	d_2	l_1	l_2	l
ACV2.25.077.23M12	25	M12	12,5	23	77	87,5	240
ACV2.32.023.23M12	32	M12	12,5	23	23	54	160
ACV2.32.0595.23M12	32	M12	12,5	23	59,5	134	300
ACV2.32.066.30M16	32	M16	17	30	66	68,7	160
ACV2.32.146.30M16	32	M16	17	30	146	148,7	300

4

Maximale Schnittleistung und minimaler Verschleiß. Vollhartmetall-Schaftfräser für die Bearbeitung nahezu aller gängigen Materialien.

*Great performance and minimal wear
for machining all materials.*

Massime prestazioni di taglio con minima usura.
Frese in metallo duro per la lavorazione
dei principali materiali comuni.



ARNO® VHM-SCHAFTFRÄSER

Ausgezeichnete Verschleißfestigkeit und sehr hohe Standzeiten zeichnen die ARNO Vollhartmetall-Schaftfräser aus. Sie können unterschiedliche Ausführungen für die verschiedensten Materialien wie Stahl, Guss, Aluminium oder exotische Materialien passend zu Ihrer Anwendung auswählen.

The Arno range of solid carbide milling cutters have tools especially suitable for steel, hardened steel, aluminium and exotic materials, all delivering excellent tool life and performance.

L'ampia gamma di frese in Metallo Duro ARNO contempla prodotti dalla eccellente resistenza all'usura ed elevata durata. Diverse tipologie disponibili per una varietà di materiali come acciaio, acciaio legato, alluminio, materiali esotici o per la vostra specifica applicazione.

Weitere ARNO Highlights finden Sie unter:

For further ARNO highlights please see:

Per ulteriori informazioni visitate il nostro sito:

www.arno.de

Eckfräser / Square shoulder cutter / Frese per spallamenti

Empfohlene Schnittwerte 90ES...P10 / Cutting datas / Parametri di taglio

Werkstoff Material Materiale	Schlichten/Finishing/Finitura			Mittlere Bearbeitung/ Medium machining/Media asportazioni			Schruppen/Roughing/Sgrossatura		
	v_c [m/min]	f_z [mm]	a_p [mm]	v_c [m/min]	f_z [mm]	a_p [mm]	v_c [m/min]	f_z [mm]	a_p [mm]
Unlegierte und legierte Stähle <i>Unalloyed and alloyed steel</i> Acciai non legati o debolmente legati	110–350	0,05–0,10	0,1–2,0	110–280	0,08–0,15	2,0–4,0	100–180	0,15–0,20	4,0–8,0
Nichtrostender Stahl <i>Stainless steel</i> Acciai inossidabili	100–250	0,05–0,10	0,1–2,0	80–180	0,08–0,15	2,0–4,0	70–160	0,15–0,20	4,0–8,0
Eisenguss <i>Cast iron</i> Ghisa grigia	120–290	0,05–0,10	0,1–2,0	110–280	0,1–0,15	2,0–4,0	100–220	0,15–0,20	4,0–8,0
Nichteisenmetalle <i>Non-ferrous metals</i> Metalli non ferrosi	700–1200	0,05–0,15	0,1–2,0	400–800	0,05–0,15	2,0–4,0	270–500	0,05–0,18	4,0–8,0
Hochwarmfeste Legierungen <i>High temperature resistant alloys</i> Leghe refrattarie, Superleghe	–	–	–	20–70	0,08–0,15	2,0–4,0	–	–	–

Empfohlene Schnittwerte 90EA...P10 / Cutting datas / Parametri di taglio

Werkstoff Material Materiale	Schlichten/Finishing/Finitura			Mittlere Bearbeitung/ Medium machining/Media asportazioni			Schruppen/Roughing/Sgrossatura		
	v_c [m/min]	f_z [mm]	a_p [mm]	v_c [m/min]	f_z [mm]	a_p [mm]	v_c [m/min]	f_z [mm]	a_p [mm]
Unlegierte und legierte Stähle <i>Unalloyed and alloyed steel</i> Acciai non legati o debolmente legati	120–280	0,08–0,15	0,2–2,0	100–250	0,10–0,25	2,0–4,5	80–200	0,12–0,22	4,5–8,0
Nichtrostender Stahl <i>Stainless steel</i> Acciai inossidabili	80–230	0,05–0,15	0,2–2,0	90–170	0,08–0,12	2,0–4,5	–	–	–
Eisenguss <i>Cast iron</i> Ghisa grigia	200–350	0,05–0,15	0,2–2,0	180–300	0,10–0,12	2,0–4,5	140–280	0,10–0,15	4,5–8,0
Nichteisenmetalle <i>Non-ferrous metals</i> Metalli non ferrosi	700–1000	0,05–0,15	0,2–2,0	400–800	0,05–0,15	2,0–4,5	270–450	0,05–0,18	4,5–8,0
Hochwarmfeste Legierungen <i>High temperature resistant alloys</i> Leghe refrattarie, Superleghe	40–60	0,05–0,10	0,2–2,0	30–50	0,06–0,10	2,0–4,0	–	–	–

Empfohlene Schnittwerte 90ES...P16 / Cutting datas / Parametri di taglio

Werkstoff Material Materiale	Schlichten/Finishing/Finitura			Mittlere Bearbeitung/ Medium machining/Media asportazioni			Schruppen/Roughing/Sgrossatura		
	v_c [m/min]	f_z [mm]	a_p [mm]	v_c [m/min]	f_z [mm]	a_p [mm]	v_c [m/min]	f_z [mm]	a_p [mm]
Unlegierte und legierte Stähle <i>Unalloyed and alloyed steel</i> Acciai non legati o debolmente legati	120–280	0,15–0,40	0,2–3,0	120–250	0,12–0,35	3,0–8,0	90–200	0,14–0,4	8,0–15,0
Nichtrostender Stahl <i>Stainless steel</i> Acciai inossidabili	150–230	0,15–0,25	0,2–3,0	120–180	0,12–0,25	3,0–8,0	–	–	–
Eisenguss <i>Cast iron</i> Ghisa grigia	200–350	0,15–0,30	0,2–3,0	180–300	0,12–0,25	3,0–8,0	140–280	0,14–0,28	8,0–15,0
Nichteisenmetalle <i>Non-ferrous metals</i> Metalli non ferrosi	700–1000	0,08–0,30	0,2–3,0	400–750	0,04–0,20	3,0–8,0	270–450	0,06–0,25	8,0–15,0
Hochwarmfeste Legierungen <i>High temperature resistant alloys</i> Leghe refrattarie, Superleghe	40–60	0,10–0,20	0,2–3,0	30–50	0,10–0,20	3,0–7,0	–	–	–

Die Tabellenwerte sind Richtwerte. Es kann notwendig sein, die Werte den jeweiligen Bearbeitungsumständen anzupassen.
The datas cutting speeds given are approximate values. It is necessary to adjust them to the individual machining operation.
I dati indicati in tabella sono valori approssimati. Può essere necessario adattarli alle singole applicazioni di lavorazione.

Eckfräser / Square shoulder cutter / Frese per spallamenti

Empfohlene Schnittwerte 90EA. ..P16 / Cutting datas / Parametri di taglio

Werkstoff Material Materiale	Schlichten/Finishing/Finitura			Mittlere Bearbeitung/ Medium machining/Media asportazioni			Schruppen/Roughing/Sgrossatura		
	v _c [m/min]	f _z [mm]	a _p [mm]	v _c [m/min]	f _z [mm]	a _p [mm]	v _c [m/min]	f _z [mm]	a _p [mm]
Unlegierte und legierte Stähle <i>Unalloyed and alloyed steel</i> Acciai non legati o debolmente legati	120–280	0,15–0,40	0,2–3,0	120–250	0,12–0,35	3,0–8,0	90–200	0,14–0,40	8,0–15
Nichtrostender Stahl <i>Stainless steel</i> Acciai inossidabili	150–230	0,15–0,25	0,2–3,0	120–280	0,12–0,25	3,0–8,0	–	–	–
Eisenguss <i>Cast iron</i> Ghisa grigia	200–350	0,15–0,30	0,2–3,0	180–300	0,12–0,25	3,0–8,0	140–280	0,14–0,28	8,0–15
Nichteisenmetalle <i>Non-ferrous metals</i> Metalli non ferrosi	700–1000	0,08–0,30	0,2–3,0	400–750	0,04–0,20	3,0–8,0	270–450	0,06–0,25	8,0–15
Hochwarmfeste Legierungen <i>High temperature resistant alloys</i> Leghe refrattarie, Superleghe	40–60	0,10–0,20	0,2–3,0	30–50	0,10–0,20	3,0–7,0	–	–	–

Plan-Eckfräser / Facing square shoulder milling cutter / Frese per spianatura – spallamenti

Empfohlene Schnittwerte 90EA. ..D12 / Cutting datas / Parametri di taglio

Werkstoff Material Materiale	Schlichten/Finishing/Finitura			Mittlere Bearbeitung/ Medium machining/Media asportazioni			Schruppen/Roughing/Sgrossatura		
	v _c [m/min]	f _z [mm]	a _p [mm]	v _c [m/min]	f _z [mm]	a _p [mm]	v _c [m/min]	f _z [mm]	a _p [mm]
Unlegierte und legierte Stähle <i>Unalloyed and alloyed steel</i> Acciai non legati o debolmente legati	140–350	0,05–0,15	0,1–2,0	100–240	0,1–0,25	1,0–4,0	90–180	0,15–0,4	> 10
Nichtrostender Stahl <i>Stainless steel</i> Acciai inossidabili	100–250	0,05–0,15	0,1–2,0	100–240	0,1–0,25	1,0–4,0	90–180	0,15–0,4	> 10
Eisenguss <i>Cast iron</i> Ghisa grigia	140–280	0,05–0,15	0,1–2,0	90–280	0,1–0,25	1,0–4,0	80–250	0,15–0,4	> 10
Nichteisenmetalle <i>Non-ferrous metals</i> Metalli non ferrosi	1000	0,05–0,10	0,1–2,0	1000	0,1–0,25	2,0–4,0	1000	0,15–0,4	> 10
Hochwarmfeste Legierungen <i>High temperature resistant alloys</i> Leghe refrattarie, Superleghe	–	–	–	20–70	0,1–0,25	1,0–4,0	–	–	–



Eckfräser / Square shoulder cutter / Frese per spallamenti

Empfohlene Schnittwerte 95ES. ..LN10 / Cutting datas / Parametri di taglio

Werkstoff Material Materiale	Schlichten/Finishing/Finitura			Mittlere Bearbeitung/ Medium machining/Media asportazioni			Schruppen/Roughing/Sgrossatura		
	v _c [m/min]	f _z [mm]	a _p [mm]	v _c [m/min]	f _z [mm]	a _p [mm]	v _c [m/min]	f _z [mm]	a _p [mm]
Unlegierte und legierte Stähle <i>Unalloyed and alloyed steel</i> Acciai non legati o debolmente legati	–	–	–	110–280	0,08–0,15	2,0–4,0	100–180	0,15–0,20	4,0–8,0
Nichtrostender Stahl <i>Stainless steel</i> Acciai inossidabili	–	–	–	80–180	0,08–0,15	2,0–4,0	70–160	0,15–0,20	4,0–8,0
Eisenguss <i>Cast iron</i> Ghisa grigia	–	–	–	110–280	0,10–0,15	2,0–4,0	100–220	0,15–0,20	4,0–8,0
Nichteisenmetalle <i>Non-ferrous metals</i> Metalli non ferrosi	–	–	–	400–800	0,05–0,15	2,0–4,0	270–500	0,05–0,18	4,0–8,0
Hochwarmfeste Legierungen <i>High temperature resistant alloys</i> Leghe refrattarie, Superleghe	–	–	–	20–70	0,08–0,15	2,0–4,0	–	–	–

Die Tabellenwerte sind Richtwerte. Es kann notwendig sein, die Werte den jeweiligen Bearbeitungsbedingungen anzupassen.
The datas cutting speeds given are approximate values. It is necessary to adjust them to the individual machining operation.
I dati indicati in tabella sono valori approssimati. Può essere necessario adattarli alle singole applicazioni di lavorazione.

Eckfräser / Square shoulder cutter / Frese per spallamenti

Empfohlene Schnittwerte 95EA...LN15 / Cutting datas / Parametri di taglio

Werkstoff Material Materiale	Schlichten/Finishing/Finitura			Mittlere Bearbeitung/ Medium machining/Media asportazioni			Schruppen/Roughing/Sgrossatura		
	v_c [m/min]	f_z [mm]	a_p [mm]	v_c [m/min]	f_z [mm]	a_p [mm]	v_c [m/min]	f_z [mm]	a_p [mm]
Unlegierte und legierte Stähle <i>Unalloyed and alloyed steel</i> Acciai non legati o debolmente legati	–	–	–	120–250	0,12–0,35	3,0–8,0	90–200	0,14–0,40	8,0–15,0
Nichtrostender Stahl <i>Stainless steel</i> Acciai inossidabili	–	–	–	120–180	0,12–0,25	3,0–8,0	–	–	–
Eisenguss <i>Cast iron</i> Ghisa grigia	–	–	–	180–300	0,12–0,25	3,0–8,0	140–280	0,14–0,28	8,0–15,0
Nichteisenmetalle <i>Non-ferrous metals</i> Metalli non ferrosi	–	–	–	400–750	0,04–0,20	3,0–8,0	270–450	0,06–0,25	8,0–15,0
Hochwarmfeste Legierungen <i>High temperature resistant alloys</i> Leghe refrattarie, Superleghe	–	–	–	30–50	0,10–0,20	3,0–7,0	–	–	–

Planfräser / Face milling cutter / Frese per spianatura

Empfohlene Schnittwerte 75PA...E12 / Cutting datas / Parametri di taglio

Werkstoff Material Materiale	Schlichten/Finishing/Finitura			Mittlere Bearbeitung/ Medium machining/Media asportazioni			Schruppen/Roughing/Sgrossatura		
	v_c [m/min]	f_z [mm]	a_p [mm]	v_c [m/min]	f_z [mm]	a_p [mm]	v_c [m/min]	f_z [mm]	a_p [mm]
Unlegierte und legierte Stähle <i>Unalloyed and alloyed steel</i> Acciai non legati o debolmente legati	–	–	–	80–200	0,10–0,30	2,0–4,0	80–160	0,30–0,45	3,0–5,0
Nichtrostender Stahl <i>Stainless steel</i> Acciai inossidabili	–	–	–	80–200	0,10–0,30	2,0–4,0	80–110	0,30–0,45	3,0–5,0
Eisenguss <i>Cast iron</i> Ghisa grigia	–	–	–	80–200	0,10–0,30	2,0–4,0	10–200	0,30–0,45	3,0–5,0
Nichteisenmetalle <i>Non-ferrous metals</i> Metalli non ferrosi	–	–	–	> 600	0,10–0,30	2,0–4,0	> 600	0,30–0,50	3,0–5,0
Hochwarmfeste Legierungen <i>High temperature resistant alloys</i> Leghe refrattarie, Superleghe	–	–	–	25–75	0,10–0,30	2,0–4,0	–	–	–

Empfohlene Schnittwerte 60PS...E12 / Cutting datas / Parametri di taglio

Werkstoff Material Materiale	Schlichten/Finishing/Finitura			Mittlere Bearbeitung/ Medium machining/Media asportazioni			Schruppen/Roughing/Sgrossatura		
	v_c [m/min]	f_z [mm]	a_p [mm]	v_c [m/min]	f_z [mm]	a_p [mm]	v_c [m/min]	f_z [mm]	a_p [mm]
Unlegierte und legierte Stähle <i>Unalloyed and alloyed steel</i> Acciai non legati o debolmente legati	150–350	0,05–0,15	0,1–2,0	80–200 (15–80)	0,10–0,25	2,0–4,0	60–150	0,18–0,35	3,0–4,5
Nichtrostender Stahl <i>Stainless steel</i> Acciai inossidabili	150–280	0,05–0,15	0,1–2,0	80–200 (15–80)	0,10–0,25	2,0–4,0	61–150	0,18–0,35	3,0–4,5
Eisenguss <i>Cast iron</i> Ghisa grigia	150–280	0,05–0,15	0,1–2,0	120–200	0,10–0,25	2,0–4,0	80–150	0,20–0,35	3,0–4,5
Nichteisenmetalle <i>Non-ferrous metals</i> Metalli non ferrosi	700–1000	0,05–0,15	0,1–2,0	400–800	0,10–0,25	2,0–4,0	280–500	0,20–0,35	3,0–5,0
Hochwarmfeste Legierungen <i>High temperature resistant alloys</i> Leghe refrattarie, Superleghe	–	–	–	25–75	0,10–0,25	2,0–4,0	–	–	–

Die Tabellenwerte sind Richtwerte. Es kann notwendig sein, die Werte den jeweiligen Bearbeitungsumständen anzupassen.
The datas cutting speeds given are approximate values. It is necessary to adjust them to the individual machining operation.
I dati indicati in tabella sono valori approssimati. Può essere necessario adattarli alle singole applicazioni di lavorazione.

Planfräser / Face milling cutter / Frese per spianatura

Empfohlene Schnittwerte 60PA..E12 / Cutting datas / Parametri di taglio

Werkstoff Material Materiale	Schlichten/Finishing/Finitura			Mittlere Bearbeitung/ Medium machining/Media asportazioni			Schruppen/Roughing/Sgrossatura		
	v_c [m/min]	f_z [mm]	a_p [mm]	v_c [m/min]	f_z [mm]	a_p [mm]	v_c [m/min]	f_z [mm]	a_p [mm]
Unlegierte und legierte Stähle <i>Unalloyed and alloyed steel</i> Acciai non legati o debolmente legati	150–350	0,05–0,15	0,1–2,0	80–200 (15–80)	0,1–0,25	2,0–4,0	60–150	0,18–0,35	3,0–4,5
Nichtrostender Stahl <i>Stainless steel</i> Acciai inossidabili	150–280	0,05–0,15	0,1–2,0	80–200 (30–50)	0,1–0,25	2,0–4,0	60–150	0,18–0,35	3,0–4,5
Eisenguss <i>Cast iron</i> Ghisa grigia	150–280	0,05–0,15	0,1–2,0	120–200	0,1–0,25	2,0–4,0	80–150	0,20–0,35	3,0–4,5
Nichteisenmetalle <i>Non-ferrous metals</i> Metalli non ferrosi	700–1000	0,05–0,15	0,1–2,0	400–800	0,1–0,25	2,0–4,0	280–500	0,20–0,35	3,0–5,0
Hochwarmfeste Legierungen <i>High temperature resistant alloys</i> Leghe refrattarie, Superleghe	–	–	–	25–75	0,1–0,25	2,0–4,0	–	–	–

Empfohlene Schnittwerte 68PA..E13 / Cutting datas / Parametri di taglio

Werkstoff Material Materiale	Schlichten/Finishing/Finitura			Mittlere Bearbeitung/ Medium machining/Media asportazioni			Schruppen/Roughing/Sgrossatura		
	v_c [m/min]	f_z [mm]	a_p [mm]	v_c [m/min]	f_z [mm]	a_p [mm]	v_c [m/min]	f_z [mm]	a_p [mm]
Unlegierte und legierte Stähle <i>Unalloyed and alloyed steel</i> Acciai non legati o debolmente legati	150–350	0,05–0,15	0,1–2,0	80–200 (15–80)	0,10–0,25	2,0–4,0	60–150	0,18–0,35	3,0–4,5
Nichtrostender Stahl <i>Stainless steel</i> Acciai inossidabili	150–280	0,05–0,15	0,1–2,0	80–200 (30–50)	0,10–0,25	2,0–4,0	60–150	0,18–0,35	3,0–4,5
Eisenguss <i>Cast iron</i> Ghisa grigia	150–280	0,05–0,15	0,1–2,0	120–200	0,10–0,25	2,0–4,0	80–150	0,20–0,35	3,0–4,5
Nichteisenmetalle <i>Non-ferrous metals</i> Metalli non ferrosi	700–1000	0,05–0,15	0,1–2,0	400–800 (<600)	0,10–0,25	2,0–4,0	280–500	0,20–0,35	3,0–5,0
Hochwarmfeste Legierungen <i>High temperature resistant alloys</i> Leghe refrattarie, Superleghe	–	–	–	25–75	0,10–0,25	2,0–4,0	–	–	–

Empfohlene Schnittwerte 70PA..D12 / Cutting datas / Parametri di taglio

Werkstoff Material Materiale	Schlichten/Finishing/Finitura			Mittlere Bearbeitung/ Medium machining/Media asportazioni			Schruppen/Roughing/Sgrossatura		
	v_c [m/min]	f_z [mm]	a_p [mm]	v_c [m/min]	f_z [mm]	a_p [mm]	v_c [m/min]	f_z [mm]	a_p [mm]
Unlegierte und legierte Stähle <i>Unalloyed and alloyed steel</i> Acciai non legati o debolmente legati	150–350	0,05–0,15	0,1–2,0	80–200 (15–80)	0,1–0,25	2,0–4,0	60–150	0,18–0,35	3,0–4,5
Nichtrostender Stahl <i>Stainless steel</i> Acciai inossidabili	150–280	0,05–0,15	0,1–2,0	80–200 (30–50)	0,1–0,25	2,0–4,0	60–150	0,18–0,35	3,0–4,5
Eisenguss <i>Cast iron</i> Ghisa grigia	150–280	0,05–0,15	0,1–2,0	120–200	0,1–0,25	2,0–4,0	80–150	0,20–0,35	3,0–4,5
Nichteisenmetalle <i>Non-ferrous metals</i> Metalli non ferrosi	700–1000	0,05–0,15	0,1–2,0	400–800 (< 600)	0,1–0,25	2,0–4,0	280–500	0,20–0,35	3,0–5,0
Hochwarmfeste Legierungen <i>High temperature resistant alloys</i> Leghe refrattarie, Superleghe	–	–	–	25–75	0,1–0,25	2,0–4,0	–	–	–

Die Tabellenwerte sind Richtwerte. Es kann notwendig sein, die Werte den jeweiligen Bearbeitungsbedingungen anzupassen.
The datas cutting speeds given are approximate values. It is necessary to adjust them to the individual machining operation.
I dati indicati in tabella sono valori approssimati. Può essere necessario adattarli alle singole applicazioni di lavorazione.

Planfräser / Face milling cutter / Frese per spianatura

Empfohlene Schnittwerte 90ESQ. ..P10 / Cutting datas / Parametri di taglio

Werkstoff Material Materiale	Schlichten/Finishing/Finitura			Mittlere Bearbeitung/ Medium machining/Media asportazioni			Schruppen/Roughing/Sgrossatura		
	v_c [m/min]	f_z [mm]	a_p [mm]	v_c [m/min]	f_z [mm]	a_p [mm]	v_c [m/min]	f_z [mm]	a_p [mm]
Unlegierte und legierte Stähle <i>Unalloyed and alloyed steel</i> Acciai non legati o debolmente legati	110–350	0,05–0,10	0,1–2,0	110–280	0,08–0,15	2,0–4,0	100–180	0,15–0,20	4,0–8,0
Nichtrostender Stahl <i>Stainless steel</i> Acciai inossidabili	100–250	0,05–0,10	0,1–2,0	80–180	0,08–0,15	2,0–4,0	70–160	0,15–0,20	4,0–8,0
Eisenguss <i>Cast iron</i> Ghisa grigia	120–290	0,05–0,10	0,1–2,0	110–280	0,1–0,15	2,0–4,0	100–220	0,15–0,20	4,0–8,0
Nichteisenmetalle <i>Non-ferrous metals</i> Metalli non ferrosi	700–1200	0,05–0,15	0,1–2,0	400–800	0,05–0,15	2,0–4,0	270–500	0,05–0,18	4,0–8,0
Hochwarmfeste Legierungen <i>High temperature resistant alloys</i> Leghe refrattarie, Superleghe	–	–	–	20–70	0,08–0,15	2,0–4,0	–	–	–

Empfohlene Schnittwerte 90EAQ. ..P10 / Cutting datas / Parametri di taglio

Werkstoff Material Materiale	Schlichten/Finishing/Finitura			Mittlere Bearbeitung/ Medium machining/Media asportazioni			Schruppen/Roughing/Sgrossatura		
	v_c [m/min]	f_z [mm]	a_p [mm]	v_c [m/min]	f_z [mm]	a_p [mm]	v_c [m/min]	f_z [mm]	a_p [mm]
Unlegierte und legierte Stähle <i>Unalloyed and alloyed steel</i> Acciai non legati o debolmente legati	120–280	0,08–0,15	0,2–2,0	100–250	0,10–0,25	2,0–4,5	80–200	0,12–0,22	4,5–8,0
Nichtrostender Stahl <i>Stainless steel</i> Acciai inossidabili	80–230	0,05–0,15	0,2–2,0	90–170	0,08–0,12	2,0–4,5	–	–	–
Eisenguss <i>Cast iron</i> Ghisa grigia	200–350	0,05–0,15	0,2–2,0	180–300	0,10–0,12	2,0–4,5	140–280	0,10–0,15	4,5–8,0
Nichteisenmetalle <i>Non-ferrous metals</i> Metalli non ferrosi	700–1000	0,05–0,15	0,2–2,0	400–800	0,05–0,15	2,0–4,5	270–450	0,05–0,18	4,5–8,0
Hochwarmfeste Legierungen <i>High temperature resistant alloys</i> Leghe refrattarie, Superleghe	40–60	0,05–0,10	0,2–2,0	30–50	0,06–0,10	2,0–4,0	–	–	–

Planfräser / Face milling cutter / Frese per spianatura

Empfohlene Schnittwerte 90EAQ. ..P16 / Cutting datas / Parametri di taglio

Werkstoff Material Materiale	Schlichten/Finishing/Finitura			Mittlere Bearbeitung/ Medium machining/Media asportazioni			Schruppen/Roughing/Sgrossatura		
	v_c [m/min]	f_z [mm]	a_p [mm]	v_c [m/min]	f_z [mm]	a_p [mm]	v_c [m/min]	f_z [mm]	a_p [mm]
Unlegierte und legierte Stähle <i>Unalloyed and alloyed steel</i> Acciai non legati o debolmente legati	120–280	0,15–0,40	0,2–3,0	120–250	0,12–0,35	3,0–8,0	90–200	0,14–0,40	8,0–15,0
Nichtrostender Stahl <i>Stainless steel</i> Acciai inossidabili	150–230	0,15–0,25	0,2–3,0	120–280	0,12–0,25	3,0–8,0	–	–	–
Eisenguss <i>Cast iron</i> Ghisa grigia	200–350	0,15–0,30	0,2–3,0	180–300	0,12–0,25	3,0–8,0	140–280	0,14–0,28	8,0–15,0
Nichteisenmetalle <i>Non-ferrous metals</i> Metalli non ferrosi	700–1000	0,08–0,30	0,2–3,0	400–750	0,04–0,20	3,0–8,0	270–450	0,06–0,25	8,0–15,0
Hochwarmfeste Legierungen <i>High temperature resistant alloys</i> Leghe refrattarie, Superleghe	40–60	0,10–0,20	0,2–3,0	30–50	0,10–0,20	3,0–7,0	–	–	–

Die Tabellenwerte sind Richtwerte. Es kann notwendig sein, die Werte den jeweiligen Bearbeitungsumständen anzupassen.
The datas cutting speeds given are approximate values. It is necessary to adjust them to the individual machining operation.
I dati indicati in tabella sono valori approssimati. Può essere necessario adattarli alle singole applicazioni di lavorazione.

Schaftschruppfräser / Shank roughing cutter / Frese a riccio

Empfohlene Schnittwerte 90ESS. ..P10 / Cutting datas / Parametri di taglio

Werkstoff Material Materiale	Schlichten/Finishing/Finitura			Mittlere Bearbeitung/ Medium machining/Media asportazioni			Schruppen/Roughing/Sgrossatura		
	v _c [m/min]	f _z [mm]	a _p [mm]	v _c [m/min]	f _z [mm]	a _p [mm]	v _c [m/min]	f _z [mm]	a _p [mm]
Unlegierte und legierte Stähle <i>Unalloyed and alloyed steel</i> Acciai non legati o debolmente legati	–	–	–	80–180	0,05–0,15	< l ₁	60–120	0,15–0,20	< l ₁
Nichtrostender Stahl <i>Stainless steel</i> Acciai inossidabili	–	–	–	80–180	0,08–0,15	< l ₁	60–120	0,15–0,20	< l ₁
Eisenguss <i>Cast iron</i> Ghisa grigia	–	–	–	100–180	0,10–0,15	< l ₁	80–150	0,15–0,20	< l ₁
Nichteisenmetalle <i>Non-ferrous metals</i> Metalli non ferrosi	–	–	–	< 2000	0,10–0,15	< l ₁	< 2000	0,15–0,20	< l ₁
Hochwarmfeste Legierungen <i>High temperature resistant alloys</i> Leghe refrattarie, Superleghe	–	–	–	–	–	–	–	–	–

Aufsteckschruppfräser / Shell type roughing cutter / Frese a riccio

Empfohlene Schnittwerte 90EAS. ..P10 / Cutting datas / Parametri di taglio

Werkstoff Material Materiale	Schlichten/Finishing/Finitura			Mittlere Bearbeitung/ Medium machining/Media asportazioni			Schruppen/Roughing/Sgrossatura		
	v _c [m/min]	f _z [mm]	a _p [mm]	v _c [m/min]	f _z [mm]	a _p [mm]	v _c [m/min]	f _z [mm]	a _p [mm]
Unlegierte und legierte Stähle <i>Unalloyed and alloyed steel</i> Acciai non legati o debolmente legati	–	–	–	80–180	0,05–0,15	< l ₁	60–120	0,15–0,20	< l ₁
Nichtrostender Stahl <i>Stainless steel</i> Acciai inossidabili	–	–	–	80–180	0,08–0,15	< l ₁	60–120	0,15–0,20	< l ₁
Eisenguss <i>Cast iron</i> Ghisa grigia	–	–	–	100–180	0,10–0,15	< l ₁	80–150	0,15–0,20	< l ₁
Nichteisenmetalle <i>Non-ferrous metals</i> Metalli non ferrosi	–	–	–	< 2000	0,10–0,15	< l ₁	< 2000	0,15–0,20	< l ₁
Hochwarmfeste Legierungen <i>High temperature resistant alloys</i> Leghe refrattarie, Superleghe	–	–	–	–	–	–	–	–	–



Schaftschruppfräser / Shank roughing cutter / Frese a riccio

Empfohlene Schnittwerte 90ESS. ..P16 / Cutting datas / Parametri di taglio

Werkstoff Material Materiale	Schlichten/Finishing/Finitura			Mittlere Bearbeitung/ Medium machining/Media asportazioni			Schruppen/Roughing/Sgrossatura		
	v _c [m/min]	f _z [mm]	a _p [mm]	v _c [m/min]	f _z [mm]	a _p [mm]	v _c [m/min]	f _z [mm]	a _p [mm]
Unlegierte und legierte Stähle <i>Unalloyed and alloyed steel</i> Acciai non legati o debolmente legati	–	–	–	80–180	0,05–0,15	< l ₁	60–120	0,15–0,20	< l ₁
Nichtrostender Stahl <i>Stainless steel</i> Acciai inossidabili	–	–	–	80–180	0,08–0,15	< l ₁	60–120	0,15–0,20	< l ₁
Eisenguss <i>Cast iron</i> Ghisa grigia	–	–	–	100–180	0,10–0,15	< l ₁	80–150	0,15–0,20	< l ₁
Nichteisenmetalle <i>Non-ferrous metals</i> Metalli non ferrosi	–	–	–	< 2000	0,10–0,15	< l ₁	< 2000	0,15–0,20	< l ₁
Hochwarmfeste Legierungen <i>High temperature resistant alloys</i> Leghe refrattarie, Superleghe	–	–	–	–	–	–	–	–	–

Die Tabellenwerte sind Richtwerte. Es kann notwendig sein, die Werte den jeweiligen Bearbeitungsbedingungen anzupassen.
The datas cutting speeds given are approximate values. It is necessary to adjust them to the individual machining operation.
I dati indicati in tabella sono valori approssimati. Può essere necessario adattarli alle singole applicazioni di lavorazione.

Aufsteckschruppfräser / Shell type roughing cutter / Frese a riccio

Empfohlene Schnittwerte 90EAS...P16 / Cutting datas / Parametri di taglio

Werkstoff Material Materiale	Schlichten/Finishing/Finitura			Mittlere Bearbeitung/ Medium machining/Media asportazioni			Schruppen/Roughing/Sgrossatura		
	v _c [m/min]	f _z [mm]	a _p [mm]	v _c [m/min]	f _z [mm]	a _p [mm]	v _c [m/min]	f _z [mm]	a _p [mm]
Unlegierte und legierte Stähle <i>Unalloyed and alloyed steel</i> Acciai non legati o debolmente legati	–	–	–	80–180	0,08–0,15	< l ₁	60–120	0,15–0,20	< l ₁
Nichtrostender Stahl <i>Stainless steel</i> Acciai inossidabili	–	–	–	80–180	0,08–0,15	< l ₁	60–120	0,15–0,20	< l ₁
Eisenguss <i>Cast iron</i> Ghisa grigia	–	–	–	100–180	0,10–0,15	< l ₁	80–150	0,15–0,20	< l ₁
Nichteisenmetalle <i>Non-ferrous metals</i> Metalli non ferrosi	–	–	–	800	0,10–0,15	< l ₁	800	0,15–0,20	< l ₁
Hochwarmfeste Legierungen <i>High temperature resistant alloys</i> Leghe refrattarie, Superleghe	–	–	–	–	–	–	–	–	–

Einschraubfräser / Threaded milling cutter / Fresa filettata

Empfohlene Schnittwerte ACME90... / Cutting datas / Parametri di taglio

Werkstoff Material Materiale	Schlichten/Finishing/Finitura			Mittlere Bearbeitung/ Medium machining/Media asportazioni			Schruppen/Roughing/Sgrossatura		
	v _c [m/min]	f _z [mm]	a _p [mm]	v _c [m/min]	f _z [mm]	a _p [mm]	v _c [m/min]	f _z [mm]	a _p [mm]
Unlegierte und legierte Stähle <i>Unalloyed and alloyed steel</i> Acciai non legati o debolmente legati	100–310	0,05–0,10	0,1–2,0	100–260	0,08–0,15	2,0–4,0	–	–	–
Nichtrostender Stahl <i>Stainless steel</i> Acciai inossidabili	80–240	0,05–0,10	0,1–2,0	70–160	0,08–0,15	2,0–4,0	–	–	–
Eisenguss <i>Cast iron</i> Ghisa grigia	100–280	0,05–0,10	0,1–2,0	100–260	0,10–0,15	2,0–4,0	–	–	–
Nichteisenmetalle <i>Non-ferrous metals</i> Metalli non ferrosi	650–1100	0,05–0,15	0,1–2,0	350–800	0,05–0,15	2,0–4,0	–	–	–
Hochwarmfeste Legierungen <i>High temperature resistant alloys</i> Leghe refrattarie, Superleghe	–	–	–	20–70	0,07–0,12	2,0–4,0	–	–	–

Empfohlene Schnittwerte ACME40... / Cutting datas / Parametri di taglio

Werkstoff Material Materiale	Schlichten/Finishing/Finitura			Mittlere Bearbeitung/ Medium machining/Media asportazioni			Schruppen/Roughing/Sgrossatura		
	v _c [m/min]	f _z [mm]	a _p [mm]	v _c [m/min]	f _z [mm]	a _p [mm]	v _c [m/min]	f _z [mm]	a _p [mm]
Unlegierte und legierte Stähle <i>Unalloyed and alloyed steel</i> Acciai non legati o debolmente legati	100–280	0,08–0,12	0,1–0,8	120–240	0,08–0,20	0,8–2,5	70–180	0,12–0,25	2,5–4,0
Nichtrostender Stahl <i>Stainless steel</i> Acciai inossidabili	80–200	0,06–0,12	0,1–0,8	80–170	0,08–0,14	0,8–2,5	–	–	–
Eisenguss <i>Cast iron</i> Ghisa grigia	200–350	0,08–0,12	0,1–0,8	170–300	0,08–0,18	0,8–2,5	130–270	0,10–0,22	2,5–4,0
Nichteisenmetalle <i>Non-ferrous metals</i> Metalli non ferrosi	700–900	0,05–0,12	0,1–0,8	400–750	0,05–0,12	0,8–2,5	270–420	0,05–0,12	2,5–4,0
Hochwarmfeste Legierungen <i>High temperature resistant alloys</i> Leghe refrattarie, Superleghe	40–60	0,06–0,10	0,1–0,8	30–50	0,08–0,10	0,8–2,5	–	–	–

Die Tabellenwerte sind Richtwerte. Es kann notwendig sein, die Werte den jeweiligen Bearbeitungsumständen anzupassen.
The datas cutting speeds given are approximate values. It is necessary to adjust them to the individual machining operation.
I dati indicati in tabella sono valori approssimati. Può essere necessario adattarli alle singole applicazioni di lavorazione.

Planfräser / Face milling cutter / Frese per spianatura

Empfohlene Schnittwerte ACMA40... / Cutting datas / Parametri di taglio

Werkstoff Material Materiale	Schlichten/Finishing/Finitura			Mittlere Bearbeitung/ Medium machining/Media asportazioni			Schruppen/Roughing/Sgrossatura		
	v _c [m/min]	f _z [mm]	a _p [mm]	v _c [m/min]	f _z [mm]	a _p [mm]	v _c [m/min]	f _z [mm]	a _p [mm]
Unlegierte und legierte Stähle <i>Unalloyed and alloyed steel</i> Acciai non legati o debolmente legati	–	–	–	150–320	0,15–0,40	0,2–3,0	120–280	0,15–0,6	1,0–4,0
Nichtrostender Stahl <i>Stainless steel</i> Acciai inossidabili	–	–	–	100–200	0,10–0,30	0,1–1,5	100–180	0,15–0,4	0,5–3,0
Eisenguss <i>Cast iron</i> Ghisa grigia	–	–	–	150–300	0,15–0,35	0,1–1,5	130–280	0,15–0,4	0,5–3,0
Nichteisenmetalle <i>Non-ferrous metals</i> Metalli non ferrosi	–	–	–	400–800	0,10–0,35	0,2–3,0	300–700	0,10–0,4	0,5–4,0
Hochwarmfeste Legierungen <i>High temperature resistant alloys</i> Leghe refrattarie, Superleghe	–	–	–	–	–	–	–	–	–

Fasfräser / Chamfering cutter / Frese per smussi e svasature

Empfohlene Schnittwerte AF45... / Cutting datas / Parametri di taglio

Werkstoff Material Materiale	Schlichten/Finishing/Finitura			Mittlere Bearbeitung/ Medium machining/Media asportazioni			Schruppen/Roughing/Sgrossatura		
	v _c [m/min]	f _z [mm]	a _p [mm]	v _c [m/min]	f _z [mm]	a _p [mm]	v _c [m/min]	f _z [mm]	a _p [mm]
Unlegierte und legierte Stähle <i>Unalloyed and alloyed steel</i> Acciai non legati o debolmente legati	–	–	–	120–250	0,05–0,30	–	–	–	–
Nichtrostender Stahl <i>Stainless steel</i> Acciai inossidabili	–	–	–	140–180	0,05–0,25	–	–	–	–
Eisenguss <i>Cast iron</i> Ghisa grigia	–	–	–	180–300	0,05–0,25	–	–	–	–
Nichteisenmetalle <i>Non-ferrous metals</i> Metalli non ferrosi	–	–	–	400–750	0,05–0,35	–	–	–	–
Hochwarmfeste Legierungen <i>High temperature resistant alloys</i> Leghe refrattarie, Superleghe	–	–	–	–	–	–	–	–	–



Empfohlene Schnittwerte AFS45. ...C16 / Cutting datas / Parametri di taglio

Werkstoff Material Materiale	Schlichten/Finishing/Finitura			Mittlere Bearbeitung/ Medium machining/Media asportazioni			Schruppen/Roughing/Sgrossatura		
	v _c [m/min]	f _z [mm]	a _p [mm]	v _c [m/min]	f _z [mm]	a _p [mm]	v _c [m/min]	f _z [mm]	a _p [mm]
Unlegierte und legierte Stähle <i>Unalloyed and alloyed steel</i> Acciai non legati o debolmente legati	70–90	0,03–0,06	0,1–0,3	70–90	0,03–0,06	0,1–0,3	70–90	0,03–0,06	0,1–0,3
Nichtrostender Stahl <i>Stainless steel</i> Acciai inossidabili	70–90	0,03–0,06	0,1–0,3	70–90	0,03–0,06	0,1–0,3	70–90	0,03–0,06	0,1–0,3
Eisenguss <i>Cast iron</i> Ghisa grigia	70–90	0,03–0,06	0,1–0,3	70–90	0,03–0,06	0,1–0,3	70–90	0,03–0,06	0,1–0,3
Nichteisenmetalle <i>Non-ferrous metals</i> Metalli non ferrosi	70–90	0,03–0,06	0,1–0,3	70–90	0,03–0,06	0,1–0,3	70–90	0,03–0,06	0,1–0,3
Hochwarmfeste Legierungen <i>High temperature resistant alloys</i> Leghe refrattarie, Superleghe	70–90	0,03–0,06	0,1–0,3	70–90	0,03–0,06	0,1–0,3	70–90	0,03–0,06	0,1–0,3

Die Tabellenwerte sind Richtwerte. Es kann notwendig sein, die Werte den jeweiligen Bearbeitungsbedingungen anzupassen.
The datas cutting speeds given are approximate values. It is necessary to adjust them to the individual machining operation.
I dati indicati in tabella sono valori approssimati. Può essere necessario adattarli alle singole applicazioni di lavorazione.

Fasfräser / Chamfering cutter / Frese per smussi e svasature

Empfohlene Schnittwerte AFS ..C11/C16 / Cutting datas / Parametri di taglio

Werkstoff Material Materiale	Schlichten/Finishing/Finitura			Mittlere Bearbeitung/ Medium machining/Media asportazioni			Schruppen/Roughing/Sgrossatura		
	v_c [m/min]	f_z [mm]	a_p [mm]	v_c [m/min]	f_z [mm]	a_p [mm]	v_c [m/min]	f_z [mm]	a_p [mm]
Unlegierte und legierte Stähle <i>Unalloyed and alloyed steel</i> Acciai non legati o debolmente legati	–	–	–	120–250	0,05–0,10	1,0–7,5	–	–	–
Nichtrostender Stahl <i>Stainless steel</i> Acciai inossidabili	–	–	–	140–180	0,05–0,10	1,0–7,5	–	–	–
Eisenguss <i>Cast iron</i> Ghisa grigia	–	–	–	180–300	0,05–0,10	1,0–7,5	–	–	–
Nichteisenmetalle <i>Non-ferrous metals</i> Metalli non ferrosi	–	–	–	400–750	0,05–0,12	1,0–7,5	–	–	–
Hochwarmfeste Legierungen <i>High temperature resistant alloys</i> Leghe refrattarie, Superleghe	–	–	–	–	–	–	–	–	–

Empfohlene Schnittwerte AFS45. ..T16 / Cutting datas / Parametri di taglio

Werkstoff Material Materiale	Schlichten/Finishing/Finitura			Mittlere Bearbeitung/ Medium machining/Media asportazioni			Schruppen/Roughing/Sgrossatura		
	v_c [m/min]	f_z [mm]	a_p [mm]	v_c [m/min]	f_z [mm]	a_p [mm]	v_c [m/min]	f_z [mm]	a_p [mm]
Unlegierte und legierte Stähle <i>Unalloyed and alloyed steel</i> Acciai non legati o debolmente legati	70–90	0,08–0,15	1,0–7,5	70–90	0,08–0,15	1,0–7,5	70–90	0,08–0,15	1,0–7,5
Nichtrostender Stahl <i>Stainless steel</i> Acciai inossidabili	70–90	0,08–0,15	1,0–7,5	70–90	0,08–0,15	1,0–7,5	70–90	0,08–0,15	1,0–7,5
Eisenguss <i>Cast iron</i> Ghisa grigia	70–90	0,08–0,15	1,0–7,5	70–90	0,08–0,15	1,0–7,5	70–90	0,08–0,15	1,0–7,5
Nichteisenmetalle <i>Non-ferrous metals</i> Metalli non ferrosi	70–90	0,08–0,15	1,0–7,5	70–90	0,08–0,15	1,0–7,5	70–90	0,08–0,15	1,0–7,5
Hochwarmfeste Legierungen <i>High temperature resistant alloys</i> Leghe refrattarie, Superleghe	70–90	0,08–0,15	1,0–7,5	70–90	0,08–0,15	1,0–7,5	70–90	0,08–0,15	1,0–7,5

Empfohlene Schnittwerte AFA.....P10 / Cutting datas / Parametri di taglio

Werkstoff Material Materiale	Schlichten/Finishing/Finitura			Mittlere Bearbeitung/ Medium machining/Media asportazioni			Schruppen/Roughing/Sgrossatura		
	v_c [m/min]	f_z [mm]	a_p [mm]	v_c [m/min]	f_z [mm]	a_p [mm]	v_c [m/min]	f_z [mm]	a_p [mm]
Unlegierte und legierte Stähle <i>Unalloyed and alloyed steel</i> Acciai non legati o debolmente legati	–	–	–	80–180	0,05–0,15	< l_1	60–120	0,15–0,20	< l_1
Nichtrostender Stahl <i>Stainless steel</i> Acciai inossidabili	–	–	–	80–180	0,08–0,15	< l_1	60–120	0,15–0,20	< l_1
Eisenguss <i>Cast iron</i> Ghisa grigia	–	–	–	100–180	0,10–0,15	< l_1	80–150	0,15–0,20	< l_1
Nichteisenmetalle <i>Non-ferrous metals</i> Metalli non ferrosi	–	–	–	< 200	0,15–0,18	< l_1	< 200	0,15–0,20	< l_1
Hochwarmfeste Legierungen <i>High temperature resistant alloys</i> Leghe refrattarie, Superleghe	–	–	–	–	–	–	–	–	–

Die Tabellenwerte sind Richtwerte. Es kann notwendig sein, die Werte den jeweiligen Bearbeitungsumständen anzupassen.
The datas cutting speeds given are approximate values. It is necessary to adjust them to the individual machining operation.
I dati indicati in tabella sono valori approssimati. Può essere necessario adattarli alle singole applicazioni di lavorazione.

Fasfräser / Chamfering cutter / Frese per smussi e svasature

Empfohlene Schnittwerte AFA...-P16 / Cutting datas / Parametri di taglio

Werkstoff Material Materiale	Schlichten/Finishing/Finitura			Mittlere Bearbeitung/ Medium machining/Media asportazioni			Schruppen/Roughing/Sgrossatura		
	v _c [m/min]	f _z [mm]	a _p [mm]	v _c [m/min]	f _z [mm]	a _p [mm]	v _c [m/min]	f _z [mm]	a _p [mm]
Unlegierte und legierte Stähle <i>Unalloyed and alloyed steel</i> Acciai non legati o debolmente legati	–	–	–	80–180	0,05–0,15	< l ₁	60–120	0,15–0,20	< l ₁
Nichtrostender Stahl <i>Stainless steel</i> Acciai inossidabili	–	–	–	80–180	0,08–0,15	< l ₁	60–120	0,15–0,20	< l ₁
Eisenguss <i>Cast iron</i> Ghisa grigia	–	–	–	100–180	0,10–0,15	< l ₁	80–150	0,15–0,20	< l ₁
Nichteisenmetalle <i>Non-ferrous metals</i> Metalli non ferrosi	–	–	–	< 200	0,15–0,18	< l ₁	< 200	0,15–0,20	< l ₁
Hochwarmfeste Legierungen <i>High temperature resistant alloys</i> Leghe refrattarie, Superleghe	–	–	–	–	–	–	–	–	–

Fräser für T-Nuten / T-slot milling cutter / Frese per cave a T

Empfohlene Schnittwerte T.976W-..P. / Cutting datas / Parametri di taglio

Werkstoff Material Materiale	Schlichten/Finishing/Finitura			Mittlere Bearbeitung/ Medium machining/Media asportazioni			Schruppen/Roughing/Sgrossatura		
	v _c [m/min]	f _z [mm]	a _p [mm]	v _c [m/min]	f _z [mm]	a _p [mm]	v _c [m/min]	f _z [mm]	a _p [mm]
Unlegierte und legierte Stähle <i>Unalloyed and alloyed steel</i> Acciai non legati o debolmente legati	80–160	0,1–0,2	–	–	–	–	–	–	–
Nichtrostender Stahl <i>Stainless steel</i> Acciai inossidabili	70–140	0,1–0,2	–	–	–	–	–	–	–
Eisenguss <i>Cast iron</i> Ghisa grigia	80–150	0,1–0,2	–	–	–	–	–	–	–
Nichteisenmetalle <i>Non-ferrous metals</i> Metalli non ferrosi	–	–	–	–	–	–	–	–	–
Hochwarmfeste Legierungen <i>High temperature resistant alloys</i> Leghe refrattarie, Superleghe	–	–	–	–	–	–	–	–	–



Bohrnutfräser / Drill and slotting cutter / Frese foranti

Empfohlene Schnittwerte 72ES. ..P. / Cutting datas / Parametri di taglio

Werkstoff Material Materiale	Schlichten/Finishing/Finitura			Mittlere Bearbeitung/ Medium machining/Media asportazioni			Schruppen/Roughing/Sgrossatura		
	v _c [m/min]	f _z [mm]	a _p [mm]	v _c [m/min]	f _z [mm]	a _p [mm]	v _c [m/min]	f _z [mm]	a _p [mm]
Unlegierte und legierte Stähle <i>Unalloyed and alloyed steel</i> Acciai non legati o debolmente legati	–	–	–	80–180	0,08–0,25	a _p *	60–120	0,15–0,20	a _p *
Nichtrostender Stahl <i>Stainless steel</i> Acciai inossidabili	–	–	–	70–170	0,08–0,25	a _p *	50–120	0,15–0,20	a _p *
Eisenguss <i>Cast iron</i> Ghisa grigia	–	–	–	100–180	0,08–0,25	a _p *	80–150	0,15–0,20	a _p *
Nichteisenmetalle <i>Non-ferrous metals</i> Metalli non ferrosi	–	–	–	400–800	0,1–0,25	a _p *	350–700	0,15–0,25	a _p *
Hochwarmfeste Legierungen <i>High temperature resistant alloys</i> Leghe refrattarie, Superleghe	–	–	–	–	–	–	–	–	–

Die Tabellenwerte sind Richtwerte. Es kann notwendig sein, die Werte den jeweiligen Bearbeitungsbedingungen anzupassen.
The datas cutting speeds given are approximate values. It is necessary to adjust them to the individual machining operation.
I dati indicati in tabella sono valori approssimati. Può essere necessario adattarli alle singole applicazioni di lavorazione.

* Maß „a_p“ siehe Tabelle Seite 148!
* Dimension „a_p“ refer to table Page 148!
* Per misura „a_p“ vedi tabella Pagina 148!

Zirkulares Eintauchen / Helical interpolation / Fresatura circolare

AP... 1003...

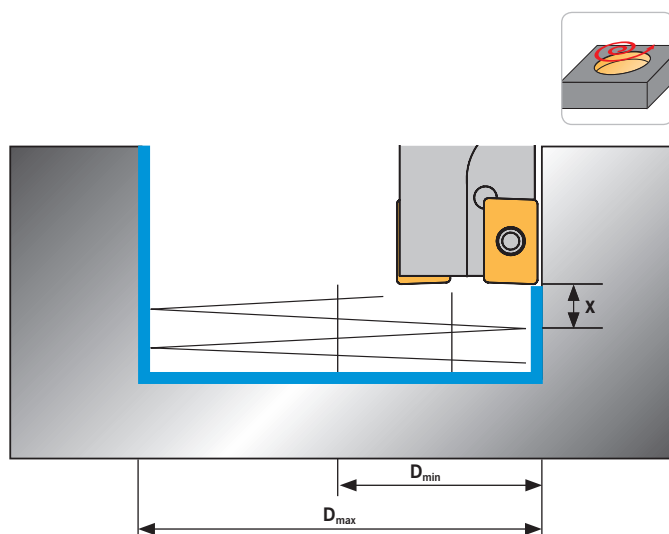

Schafffräser Shank roughing cutter Fresa a gambo cilindrico	D_{min}	D_{max}	X
90ES.010R.P10	16	20	1
90ES.011R.P10	20	22	1
90ES.012R.P10	20	24	1
90ES.013R.P10	20	26	1
90ES.014R.P10	20	28	1
90ES.015R.P10	20	30	1
90ES.015,7R.P10	19	31	1
90ES.016R.P10	20	32	1
90ES.017R.P10	22	34	1
90ES.018R.P10	24	36	1
90ES.019,7R.P10	28	40	1
90ES.020R.P10	28	40	1
90ES.022R.P10	32	44	1
90ES.024,7R.P10	36	48	1
90ES.025R.P10	38	50	1
90ES.025/4R.P10	38	50	1
90ES.028R.P10	44	56	1
90ES.030R.P10	48	60	1
90ES.031,7R.P10	52	64	1
90ES.032R.P10	52	64	1

4

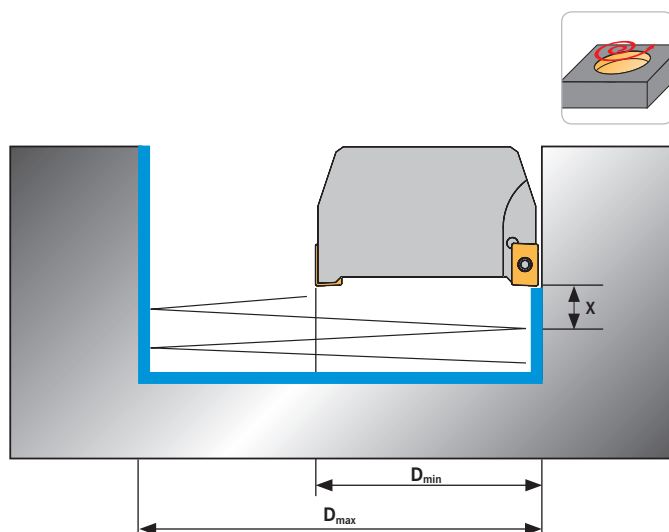

Aufsteckfräser Shell type milling cutter Fresa a manicotto	D_{min}	D_{max}	X
90EA.040R.P10	68	80	1
90EA.050R.P10	88	100	1
90EA.063R.P10	114	126	1
90EA.080R.P10	148	160	1
90EA.100R.P10	188	200	1

D_1 = kleinster Bohrungsdurchmesser
minimum bore diameter
diametro minimo di foro

D_{max} = größter Bohrungsdurchmesser für ebenen Bodenflächen
maximum bore diameter for flat area
diametro massimo foro per parte piana

Schräges Eintauchen / Ramping / Fresatura in rampa

AP... 1003...

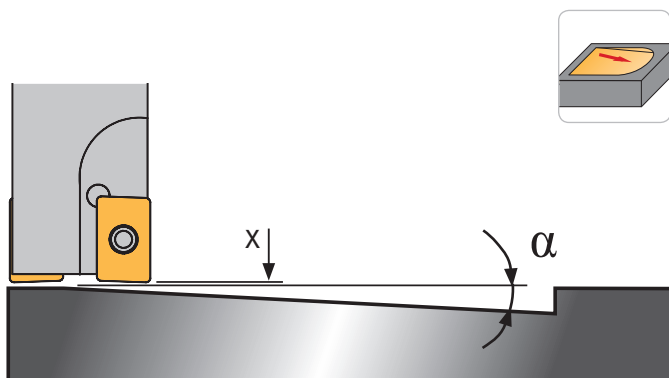

Schafffräser Shank roughing cutter Fresa a gambo cilindrico	X	α
90ES.010R.P10	1,0	11,0°
90ES.011R.P10	1,0	11,0°
90ES.012R.P10	1,0	9,0°
90ES.013R.P10	1,0	8,5°
90ES.014R.P10	1,0	8,0°
90ES.015R.P10	1,0	4,0°
90ES.015,7R.P10	1,5	4,0°
90ES.016R.P10	1,5	3,5°
90ES.017R.P10	1,5	3,0°
90ES.018R.P10	1,1	2,5°
90ES.019,7R.P10	1,4	2,0°
90ES.020R.P10	1,4	1,5°
90ES.022R.P10	1,4	1,5°
90ES.024,7R.P10	1,4	0,9°
90ES.025R.P10	1,4	0,9°
90ES.025/4R.P10	1,4	0,9°
90ES.028R.P10	1,4	0,9°
90ES.030R.P10	1,4	0,8°
90ES.031,7R.P10	1,4	0,6°
90ES.032R.P10	1,4	0,6°

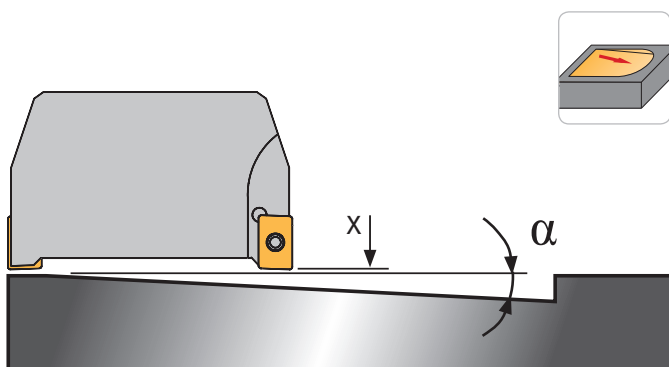

Aufsteckfräser Shell type milling cutter Fresa a manicotto	X	α
90EA.040R.P10	1,0	1,4°
90EA.050R.P10	1,0	1,4°
90EA.063R.P10	1,0	0,4°
90EA.080R.P10	1,0	0,4°
90EA.100R.P10	1,0	0,4°

D_{\min} = kleinster Bohrungsdurchmesser
minimum bore diameter
diametro minimo di foro

D_{\max} = größter Bohrungsdurchmesser für eben Bodenflächen
maximum bore diameter for flat area
diametro massimo foro per parte piana

Zirkulares Eintauchen / Helical interpolation / Fresatura circolare

AP... 1604...

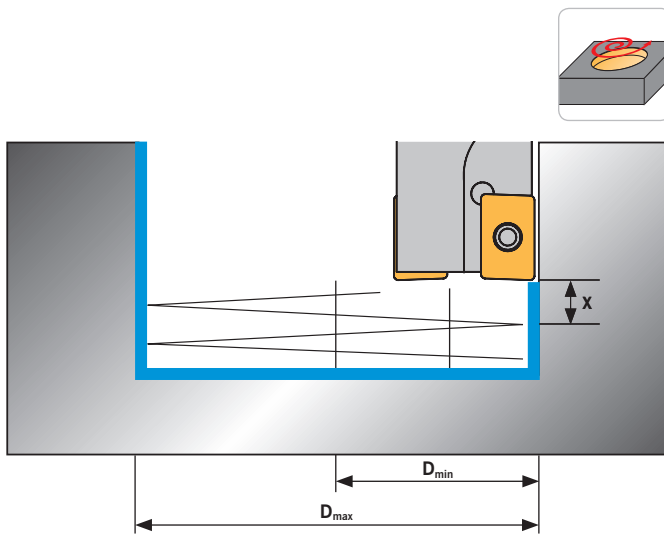

Schafffräser Shank roughing cutter Fresa a gambo cilindrico	D_{min}	D_{max}	X
90ESL.022R.P16	30	39	1,5
90ES.025R.P16	38	50	1,5
90ES.032R.P16	52	64	1,5
90ES.040R.P16	62	80	1,5

4

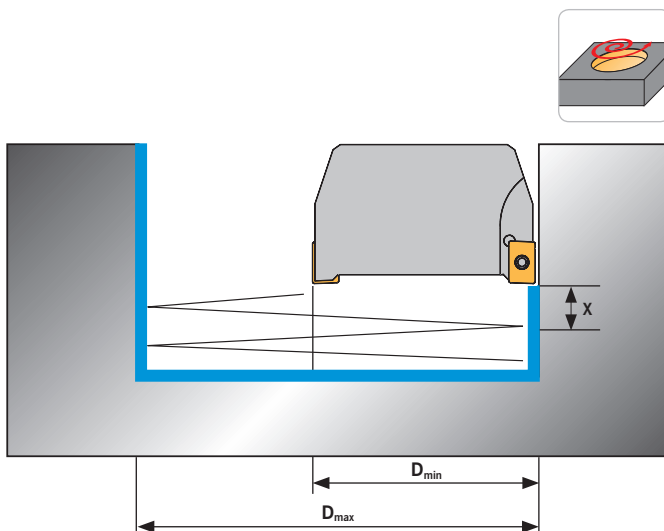

Aufsteckfräser Shell type milling cutter Fresa a manicotto	D_{min}	D_{max}	X
90EA.040RI.P16	62	80	1,5
90EA.050R.P16	82	100	1,5
90EA.063R.P16	108	126	1,5
90EA.080R.P16	142	160	1,5
90EA.100R.P16	182	200	1,5
90EA.125R.P16	232	250	1,5
90EA.160R.P16	302	320	1,5
90EA.200R.P16	382	400	1,5
90EA.250R.P16	482	500	1,5

D_1 = kleinster Bohrungsdurchmesser
minimum bore diameter
diametro minimo di foro

D_{max} = größter Bohrungsdurchmesser für eben Bodenflächen
maximum bore diameter for flat area
diametro massimo foro per parte piana

Schräges Eintauchen / Ramping / Fresatura in rampa

AP... 1604...

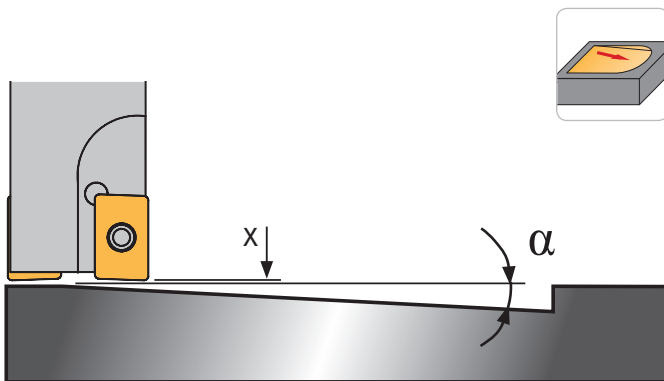

Schafffräser Shank roughing cutter Fresa a gambo cilindrico	x	α
90ES.025R.P16	1,0	3,0°
90ES.032R.P16	1,0	1,8°
90ES.040R.P16	1,0	1,3°

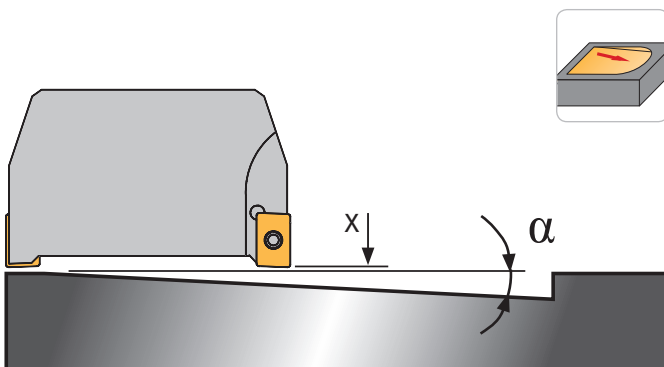

Aufsteckfräser Shell type milling cutter Fresa a manicotto	x	α
90EA.040R.P16	1,0	1,3°
90EA.050R.P16	1,0	1,0°
90EA.063R.P16	1,4	0,7°
90EA.080R.P16	1,4	0,6°
90EA.100R.P16	1,4	0,4°
90EA.125R.P16	1,4	0,3°
90EA.160R.P16	1,4	0,3°

4

D_{min} = kleinster Bohrungsdurchmesser
minimum bore diameter
diametro minimo di foro

D_{max} = größter Bohrungsdurchmesser für eben Bodenflächen
maximum bore diameter for flat area
diametro massimo foro per parte piana

Zirkulares Eintauchen / Helical interpolation / Fresatura circolare **LNMX 10... / LNMX 15...**

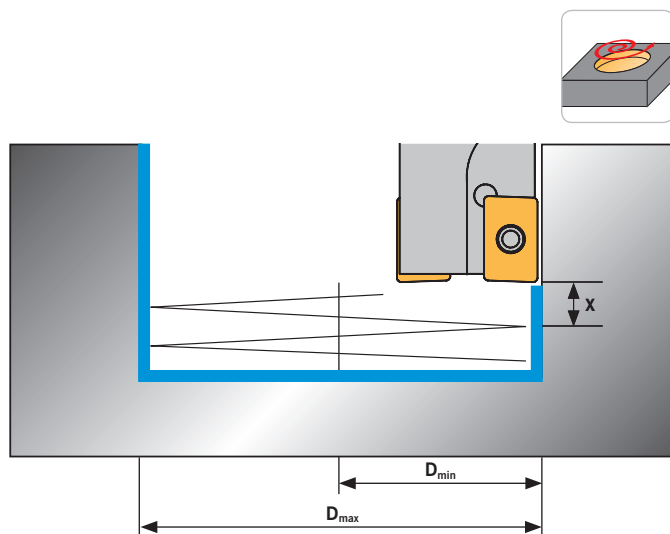

	Sackloch mit ebenem Grund Blind hole with flat bottom Foro cieco con fondo piano				Durchgangsbohrung Through hole Foro passante	
Schafffräser Shank roughing cutter Frese a gambo cilindrico	D _{min}	X	D _{max}	X	D _{min}	X
95ES.020RI.LN10	37	3	39	4	31	2
95ES.025R.LN10	47	4	49	4	41	3
95ES.032R.LN10	61	4	63	4,5	55	3,5

4

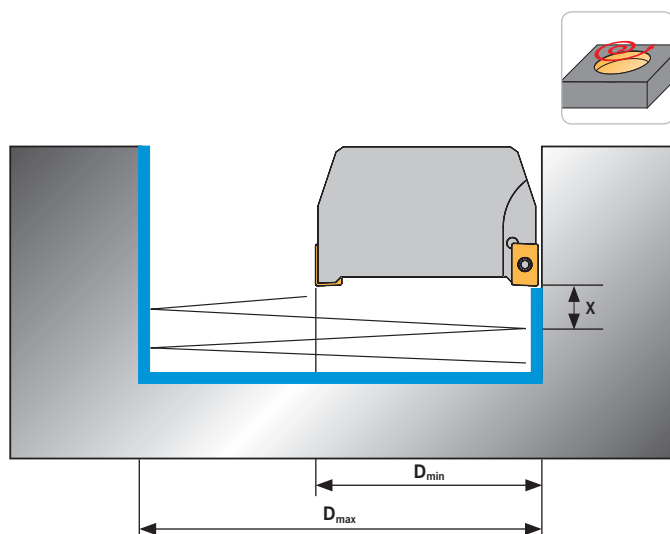

	Sackloch mit ebenem Grund Blind hole with flat bottom Foro cieco con fondo piano				Durchgangsbohrung Through hole Foro passante	
Aufsteckfräser Shell type milling cutter Fresa a manicotto	D _{min}	X	D _{max}	X	D _{min}	X
95EA.040R.LN10	77	4	79	4	71	3
95EA.050R.LN10	97	3,5	99	3,5	91	3
95EA.063R.LN10	114	3,5	120	3,5	110	3
95EA.050R.LN15	95,5	4	98	5	85	3,5
95EA.063R.LN15	121,5	5	124	5	111	5
95EA.080R.LN15	155,5	5	158	5	145	5
95EA.100R.LN15	182	5	200	5	173	5
95EA.125R.LN15	232	5	250	5	225	5

D_{min} = kleinster Bohrungsdurchmesser
minimum bore diameter
diametro minimo di foro

D_{max} = größter Bohrungsdurchmesser für eben Bodenflächen
maximum bore diameter for flat area
diametro massimo foro per parte piana

Schräges Eintauchen / Ramping / Fresatura in rampa

LNMX 10... / LNMX 15...

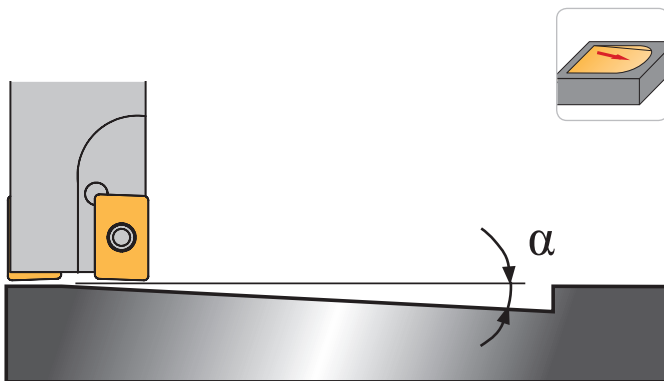

Schafffräser Shank roughing cutter Fresa a gambo cilindrico	α
95ES.020R.LN10	4°
95ES.025R.LN10	3,5°
95ES.032R.LN10	3°

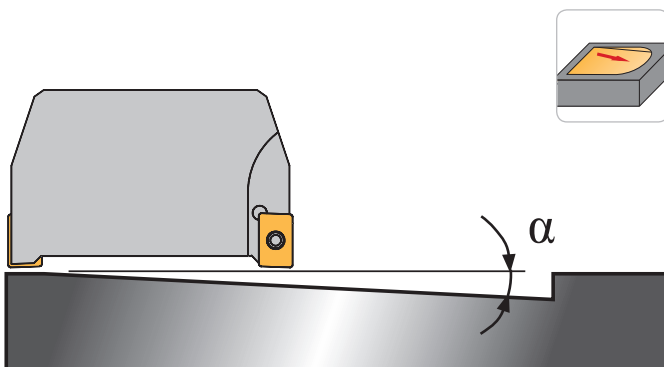

Aufsteckfräser Shell type milling cutter Fresa a manicotto	α
95EA.040R.LN10	2°
95EA.050R.LN10	1,5°
95EA.063R.LN10	1°
95EA.050R.LN15	2°
95EA.063R.LN15	2°
95EA.080R.LN15	1,5°
95EA.100R.LN15	1,5°
95EA.125R.LN15	1°

4

Zirkulares Eintauchen / Helical interpolation / Fresatura circolare

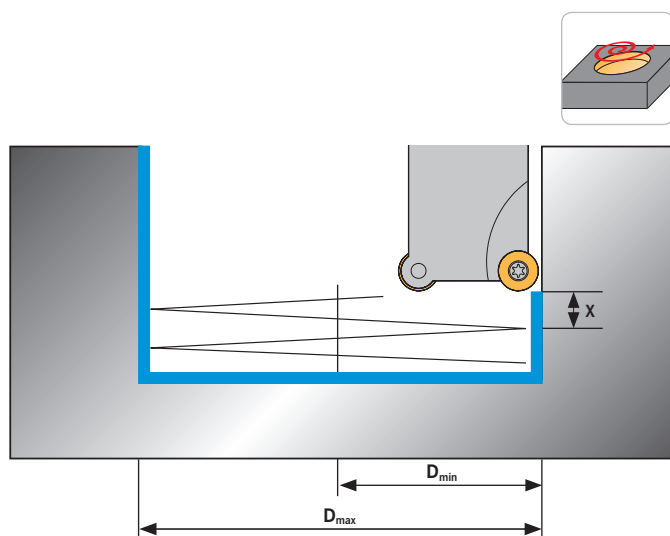

	RD.. 05		
	D _{min}	D _{max}	X
Schaftfräser Shank roughing cutter Fresa a gambo cilindrico			
ACME40.02.10.D05	11	19	1,5
ACME40.05.20.D05	31	39	2,0
ACME40.02.12.D07			
ACME40.02.15.D07			
ACME40.03.15.D07			
ACME40.04.20.D07			
ACME40.05.25.D07			
ACME40.05.30.D07			
ACME40.02.20.D10			
ACME40.02.25.D10			
ACME40.03.25.D10			
ACME40.04.30.D10			
ACME40.04.35.D10			
ACME40.05.42.D10			
ACME40.02.24.D12			
ACME40.03.35.D12			
ACME40.04.42.D12			
ACME40.02.32.D16			

4

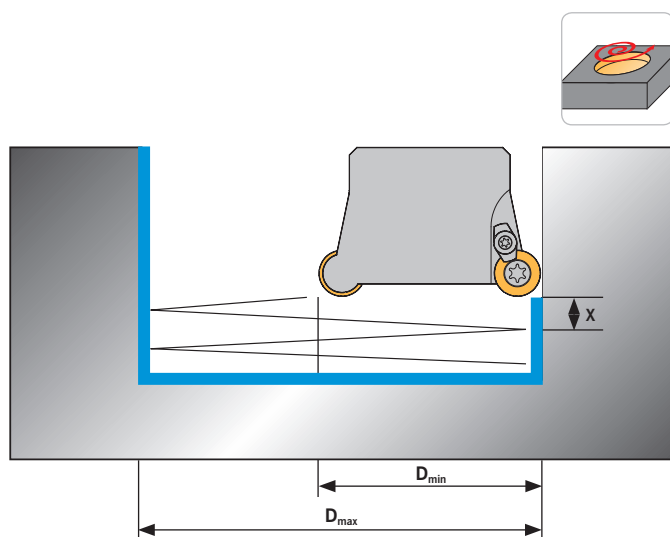

	RD.. 05		
	D _{min}	D _{max}	X
Aufsteckfräser Shell type milling cutter Fresa a manicotto			
ACMA40.04.042.D10			
ACMA40.05.052.D12			
ACMA40.04.052.D16			
ACMA40.06.066.D12			
ACMA40.05.066.D16			
ACMA40.07.080.D12			
ACMA40.06.080.D16			
ACMA40.07.100.D16			
ACMA40.08.125.D16			
ACMA40.09.160.D16			

Axiales Eintauchen / Plunge milling / Fresatura assiale

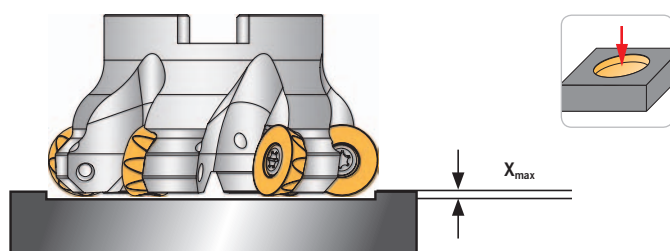

Rund-WSP RD..

RD...	X _{max}
05	1,2
07	1,8
10	2,6
12	3,6
16	4,5

Rund-WSP RD..

RD.. 07			RD.. 10			RD.. 12			RD.. 16		
D _{min}	D _{max}	X	D _{min}	D _{max}	X	D _{min}	D _{max}	X	D _{min}	D _{max}	X
13	24	1,5									
17	29	2,0									
17	29	2,0									
27	39	3,0									
37	49	3,0									
47	59	3,0									
			21,0	39	2,5						
			31,5	49	4,0						
			31,5	49	4,0						
			41,5	59	4,0						
			51,5	69	4,0						
			65,5	83	4,0						
						27,5	49	3,5			
						47,5	69	5,0			
						61,5	83	5,0			
									33,0	63	3,0

RD.. 07			RD.. 10			RD.. 12			RD.. 16		
D _{min}	D _{max}	X	D _{min}	D _{max}	X	D _{min}	D _{max}	X	D _{min}	D _{max}	X
			65,5	83	4,0						
						81,5	103	5,0			
									74,0	103	6,0
						109,5	131	5,0			
									102,0	131	6,0
						137,5	159	5,0			
									130,0	159	6,0
									170,0	199	6,0
									220,0	249	6,0
									290,0	319	6,0



Schräges Eintauchen / Ramping / Fresatura in rampa

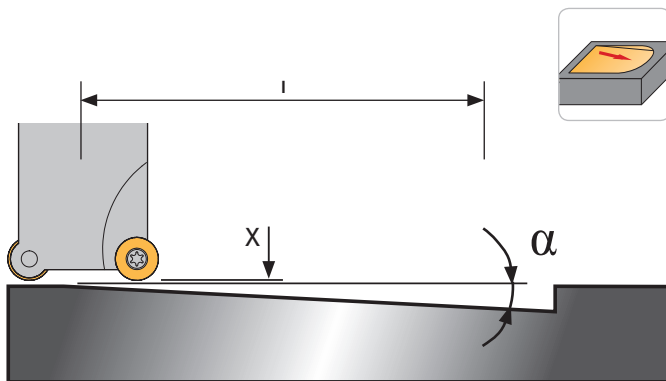

Schafffräser Shank roughing cutter Fresa a gambo cilindrico	RD.. 05		
	X	α	l
ACME40.02.10.D05	2,5	28,9°	4,52
ACME40.05.20.D05	2,5	6,9°	20,65
ACME40.02.12.D07			
ACME40.02.15.D07			
ACME40.03.15.D07			
ACME40.04.20.D07			
ACME40.05.25.D07			
ACME40.05.30.D07			
ACME40.02.20.D10			
ACME40.02.25.D10			
ACME40.03.25.D10			
ACME40.04.30.D10			
ACME40.04.35.D10			
ACME40.05.42.D10			
ACME40.02.24.D12			
ACME40.03.35.D12			
ACME40.04.42.D12			
ACME40.02.32.D16			

4

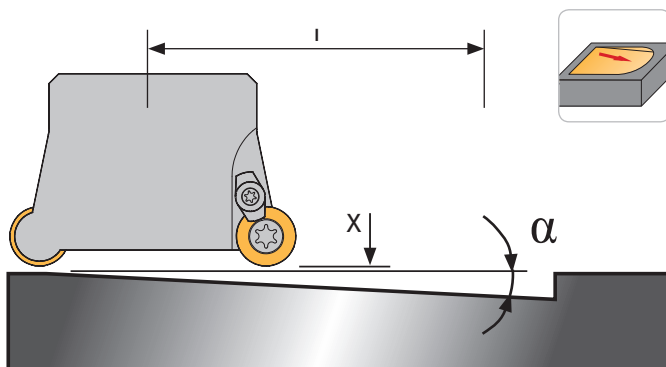

Aufsteckfräser Shell type milling cutter Fresa a manicotto	RD.. 05		
	X	α	l
ACMA40.04.042.D10			
ACMA40.05.052.D12			
ACMA40.04.052.D16			
ACMA40.06.066.D12			
ACMA40.05.066.D16			
ACMA40.07.080.D12			
ACMA40.06.080.D16			
ACMA40.07.100.D16			
ACMA40.08.125.D16			
ACMA40.09.160.D16			

Rund-WSP RD..

RD.. 07			RD.. 10			RD.. 12			RD.. 16		
X	α	I	X	α	I	X	α	I	X	α	I
3,5	22,7°	8,36									
3,5	20,0°	9,6									
3,5	20,0°	9,6									
3,5	11,0°	18									
3,5	7,3°	27,3									
3,5	5,7°	37									
			5,0	39,0°	6,17						
			5,0	14,3°	19,6						
			5,0	14,3°	19,6						
			5,0	9,3°	30,5						
			5,0	7,3°	39						
			5,0	5,4°	52,9						
						6,0	26°	12,3			
						6,0	11,0°	28,4			
						6,0	8,3°	41,1			
									8,0	43°	8,57

RD.. 07			RD.. 10			RD.. 12			RD.. 16		
X	α	I	X	α	I	X	α	I	X	α	I
			5,0	5,4°	52,9						
						6,0	5,7°	60,1			
									8,0	8,8°	51,6
						6,0	4,1°	83,7			
									8,0	6,0°	76,1
						6,0	3,2°	107,3			
									8,0	4,5°	101,6
									8,0	3,7°	123,7
									8,0	2,8°	163,5
									8,0	1,8°	254,5



Schräges Eintauchen / Ramping / Fresatura in rampa

SE... 1203...

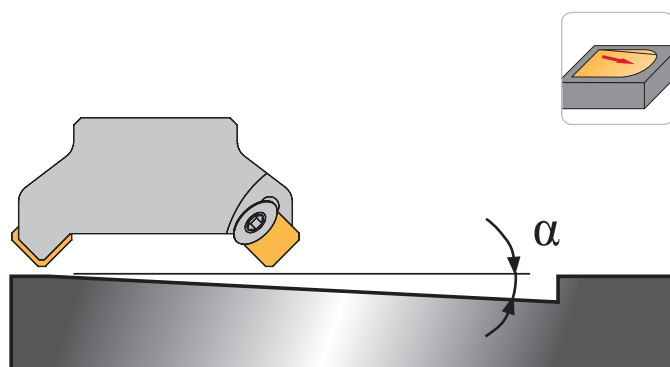

Aufsteckfräser Shell type milling cutter Fresa a manicotto	α
75PA.50R.E12	8,5°
75PA.63R.E12	6,5°
75PA.80R.E12	5,0°
75PA.100R.E12	4,0°
75PA.125R.E12	3,0°
75PA.160R.E12	2,3°
75PA.200R.E12	1,8°
75PA.250R.E12	1,4°

4

Schräges Eintauchen / Ramping / Fresatura in rampa

SE... 1204...

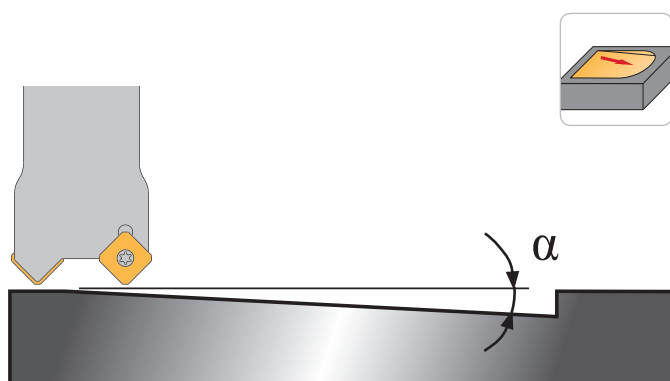

Schafffräser Shank roughing cutter Fresa a gambo cilindrico	α
60PS.25RI.E12	23,5°
60PS.32RI.E12	16,0°
60PS.40RI.E12	11,5°

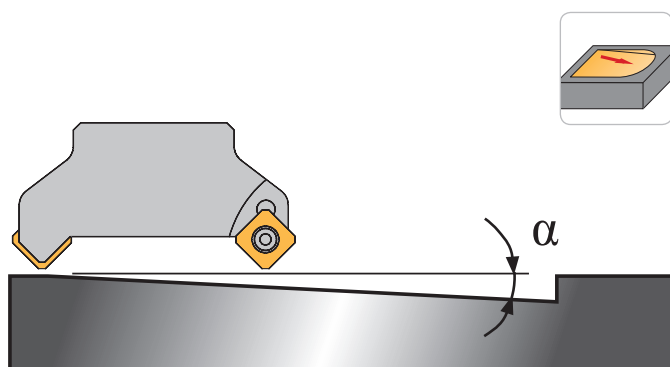

Aufsteckfräser Shell type milling cutter Fresa a manicotto	α
60PA.40R.E12-3	11,5°
60PA.40R.E12-4	11,5°
60PA.50R.E12-4	8,5°
60PA.50R.E12-5	8,5°
60PA.63R.E12-5	6,5°
60PA.63R.E12-6	6,5°
60PA.80R.E12-6	5,0°
60PA.80R.E12-7	5,0°
60PA.100R.E12-6	4,0°
60PA.100R.E12-8	4,0°
60PA.125R.E12-7	3,0°
60PA.125R.E12-9	3,0°
60PA.160R.E12-8	2,3°
60PA.160R.E12-10	2,3°

Übersicht Ersatzteile

Overview Spare Parts

Gamma utensili ricambi

Artikel / Item / Articolo
Druckschraube / Clamp screw / Vite fissaggio
BL 0
BL 1
BL 2
BL 3
BL 4
BL 5
BL 6
BL 7
BL 10
Klemmschraube / Clamping screw / Vite
CVB 35
Klemmschraube Plattensitz / Fixing screw for seat / Vite ravvicinato
V 1006
Plattensitz (schwenkbar) / Adjustable insert seat / Ravvicinato registrabile
S12N
T16N
Schlüssel-Klemmschraube / Key Clamping screw / Chiave vite
KP 1321
Schlüssel-Unterlage / Key support / Chiave sottopiacchetta
KP 3421
Schraube für Unterlagplatte / Screw support / Vite sottopiacchetta
VF 4
Schraubendreher / Screw driver / Chiave
T 5106
T 5107
T 5108
T 5109
T 5115
T 5120
Spannklaue / Clamp / Staffa
CVB 45

Artikel / Item / Articolo
Spannschraube / Screw / Vite
AS 0071
AS 0072
AS 0073
FS 243
SS 1218
SS 1221
SS 1222
SS 1225
SS 1240
SS 1290
SS 2530
SS 3500
SS 4500
SS 5000
T 2,2.04
VTX 3503
VTX 3504
VTX 405
VTX 408
Spannschraube WSP / Insert locking screw / Vite di bloccaggio
CVB 55
Unterlagplatte / Support / Sottopiacchetta
AKE 12,4
Zugschraube / Adjust. Screw / Vite regolazione
RE 1
RE 2
RE 3
RE 4
RE 5
RE 6
RE 7
RE 8

4

Die ARNO Fräser aus pulvermetallurgischem HSS Stahl sind extrem robust und verschleißfest. TiAlN/TiCN beschichtet erzielen Sie beste Leistungen bei der Zerspanung.

The ARNO powder metal cutters are extremely tough and wear resistant. Available with TiAlN/TiCN coating for excellent performance.

Le frese ARNO in HSS-PM sinterizzate sono estremamente resistenti all'usura e garantiscono prolungate vite utensile. I rivestimenti TiAlN/TiCN garantiscono migliori prestazioni in lavorazione.

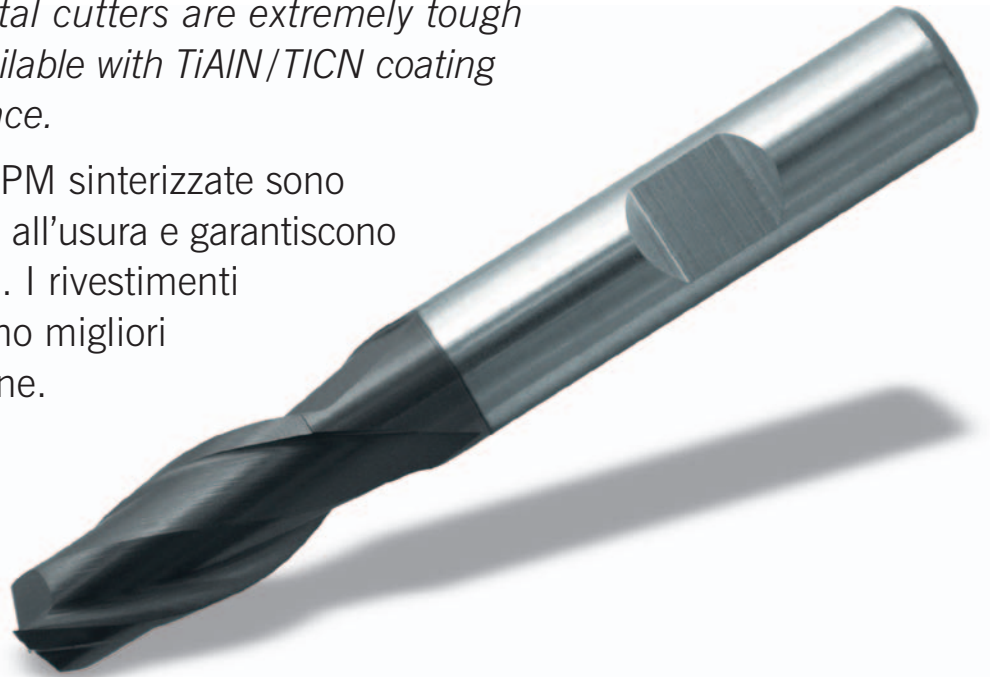

ARNO® PM-HSS FRÄSER

Ob Universalfräser für die Bearbeitung von Stahl, rostfreiem Stahl oder Gusswerkstoffen: Bei den ARNO PM-HSS Fräsern erwarten Sie hohe Oberflächenqualitäten bei maximaler Schnittleistung.

No matter whether machining steel, stainless steel, cast materials or exotics, the ARNO PM cutters provide both good surface finish and tool performance.

La fresa universale per la lavorazione di acciaio, acciaio inossidabile o ghisa: le frese ARNO PM-HSS garantiscono elevata finitura superficiale con la massima prestazione di taglio.

Weitere ARNO Highlights finden Sie unter:

For further ARNO highlights please see:

Per ulteriori informazioni visitate il nostro sito:

www.arno.de

WENDESCHNEIDPLATTEN

INDEXABLE INSERTS

INSERTI DI FRESATURA



Wendeschneidplatten

- ISO-Bezeichnungssystem
- ARNO-Spanformgeometrien
- Wendeschneidplatten
 - Hartmetall
 - Hochpositiv
 - Cermet
 - Hochharte Schneidstoffe
 - HSS-Schneidstoff

Indexable Inserts

- ISO-Designation System
- Chip Breakers
- Indexable Inserts
 - Carbide
 - High Positive
 - Cermet
 - CBN / PCD
 - HSS

Inserti

- Sistema di codifica ISO
- Geometrie di taglio ARNO
- Inserti
 - Metallo duro
 - Ultra Positivi
 - Cermet
 - Materiali extra duri
 - HSS

180 – 181

182 – 186

187 – 208

209 – 225

226 – 231

232 – 242

243 – 250

5

5

ISO-Bezeichnungssystem für Wendeschneidplatten

ISO-Designation System for indexable inserts

Sistema di identificazione ISO per Inserti a fissaggio meccanico

80° **C**
 55° **D**
 75° **E**
 86° **M**
 35° **V**

85° **A**
 82° **B**
 55° **K**

H
L
O
P
R
S
T
W

L

Plattenform

Insert shape
 Forma inserto

3° **A**
 5° **B**
 7° **C**
 15° **D**
 20° **E**
 25° **F**
 30° **G**
 0° **N**
 11° **P**

Sonstige
 Others
 Altro → **O**

D

Freiwinkel

Clearance angle
 Angolo di spoglia

Grenzabmaße [mm] Range of tolerance Campo tolleranza			Toleranzklasse Tolerance Classe tolleranza	
d ±	m ±	s ±		
0,025	0,005	0,025	A	
0,025	0,013	0,025	C	
0,025	0,025	0,025	E	
0,013	0,005	0,025	F	
0,025	0,025	0,05-0,13	G	
0,013	0,013	0,025	H	
0,05-0,15	0,005	0,025	J	
0,05-0,15	0,013	0,025	K	
0,05-0,15	0,025	0,025	L	
0,05-0,15	0,08-0,2	0,05-0,13	M	
0,05-0,15	0,08-0,2	0,025	N	
0,08-0,25	0,13-0,38	0,13	U	

Sonderausführung
 Special shape
 Forma speciale → **X**

H

Toleranzen

Tolerance
 Tolleranza costruttiva

A
C
F
G
H
J
M
N
P
Q
R
T
U
W

Sonderausführung
 Special shape
 Forma speciale → **X**

T

Plattentyp

Type of insert
 Tipo di inserto

5

ISO-Bezeichnungssystem für Wendeschneidplatten

ISO-Designation System for indexable inserts

Sistema di identificazione ISO per Inserti a fissaggio meccanico

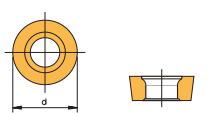

d [mm]

06
08
10
12
16
20
25
32

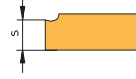
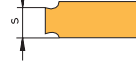

(mm)	d (inch)	d (mm)	(mm)
06	5/32	3,97	03
08	3/16	4,76	04
09	7/32	5,56	05
11	1/4	6,35	06
16	3/8	9,525	09
22	1/2	12,7	12
27	5/8	15,875	15
33	3/4	19,5	19
44	1	25,4	25

s [mm]	Kennzahl/Index/Identificativo
1,59	01
1,98	T1
2,38	02
3,18	03
3,97	T3
4,76	04
5,56	05
6,35	06
7,94	07
9,52	09

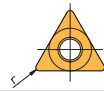

r [mm]

0,2	02
0,4	04
0,8	08
1,2	12
1,6	16
2,4	24
0	00

Einstellwinkel-Planschneide
Approach angle-Minor cutting edge
Angolo di attacco



A = 45°
D = 60°
E = 75°
F = 85°
P = 90°
Z = Sonstige
Others
Altro

Freiwinkel-Planschneide
Clearance angle-Minor cutting edge
Angolo di spoglia inferiore



B = 5°
C = 7°
D = 15°
E = 20°
F = 25°
G = 30°
N = 0°
P = 11°
Z = Sonstige
Others
Altro

OO: Runde Platte (inch)
Round insert (inch)
Inserto tondo (pollici)

MO: Runde Platte (metr.)
Round insert (metr.)
Inserto tondo (metr.)

F
Scharf
Sharp
Affilato

E
Gerundet
Rounded
Arrotondato (onato)

T
Gefast
Chamfered
Smussato (bisello)

S
Gefast und gerundet
Chamfered and rounded
Smussato e arrotondato

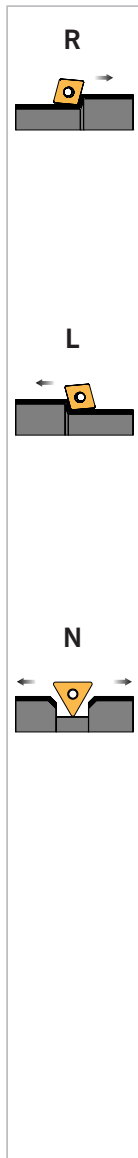

Für besondere Formen der Spanleitstufen kann an der 10. Stelle ein firmeninterner Code angeführt werden
z.B. - NMG
- NA
- ACB

Special chipbreaker shapes can be indicated by an internal company coding system at the 10th position.
e.g. - NMG
- NA
- ACB

Forme di rompitruciolo speciali con codifica personalizzata possono essere aggiunte in questo campo
Per esempio:
- NMG
- NA
- ACB

15

Schneidenlänge
Edge length
Lunghezza lato inserto

T3

Plattendicke
Insert thickness
Spessore inserto

PD

Eckenradius
Corner radius
Angolo di punta

S

Schneidkante
Edge condition
Preparazione tagliente

R

Schneidrichtung
Cutting direction
Direzione di lavoro

...

Zusatzangabe
Additional coding system
Codice aggiuntivo

- PRS

Universelle Geometrie für die Bearbeitung von Stahl, rostfreien Stählen und Gußwerkstoffen.

**- PRS**

Universal geometry for machining steel, stainless steel and cast materials.

Schlicht- und mittlere Zerspanung

Finishing and medium machining
Finitura e medie asportazioni

einseitig
single sided
singolo lato

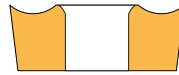
**- PRS**

Geometria universale per la lavorazione dell'acciaio, acciaio inox e ghisa.

- S

Diese positive Geometrie eignet sich besonders zur Bearbeitung von Stahl sowie rostfreien Stählen. Optimale Bearbeitung von labilen, dünnwandigen Teilen möglich.

**- S**

This positive geometry is mostly suitable for steel and stainless steel. Excellent machining of unstable and thin-walled workpieces.

Schlicht- und mittlere Zerspanung

Finishing and medium machining
Finitura e medie asportazioni

einseitig
single sided
singolo lato

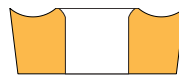
**- S**

Geometria positiva sviluppata per la finitura o la semifinitura di acciai legati e acciai inossidabili. Ottimo per la lavorazione di pareti sottili.

- U

Geometrie mit guter Verschleißfestigkeit und hoher Zähigkeit zur Bearbeitung von Stahl, austenitischem rostfreiem Stahl, warmfesten Legierungen und Kugelgraphitguss.

**- U**

Geometry with good wear resistance and high toughness for machining steel, stainless steel (austenitic), heat-resistant alloys and spheroidal cast iron.

Schlicht- und mittlere Zerspanung

Finishing and medium machining
Finitura e medie asportazioni

einseitig
single sided
singolo lato

**- U**

Geometria con buona resistenza all'usura ed elevata durezza per la lavorazione dell'acciaio, acciaio inossidabile austenitico, leghe resistenti al calore e ghisa sferoidale.

- PNR

Diese vielseitige Geometrie zeichnet sich durch ihr breites Einsatzspektrum bei allen Stahlwerkstoffen und Gusswerkstoffen aus. Sie ist ebenfalls für rostfreien Stahl geeignet. Durch ihre hohe Zähigkeit und hohen Verschleißfestigkeit ist sie die optimale Universal-schneidplatte für Ihre Fertigung.

**- PNR**

This multi purpose geometry excels due to its versatile application area in steel and cast materials. It is also very suitable for machining stainless steel, heat resistant alloys and titanium alloys. Because of its high toughness and wear resistance this is the optimum general geometry for your production.

Mittlere Zerspanung

Medium machining
Semifinitura

zweiseitig
double sided
doppio lato

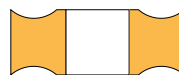
**- PNR**

Geometria universale per svariati campi applicativi nella lavorazione di acciaio e materiali da fusione. E' inoltre idoneo ad alcune lavorazioni di acciaio inossidabile, leghe refrattarie e leghe di titanio. Grazie alla buona tenacità combinata ad una ottima resistenza all'usura risulta essere la qualità ottimale per le generiche lavorazioni della vostra produzione.

- AM

Spanformgeometrie für den mittleren Zerspanungsbereich von Stahl, rostfreiem (austenitischem) Stahl und auch Gusswerkstoffen. Sehr gute Spankontrolle bei geringen bis mittleren Spantiefen und Vorschubbereichen durch die Anordnung der speziell konzipierten Spanformnoppen. Weicher Spanablauf und niedrige Schnittkräfte.

**- AM**

Chip breaker geometry for medium machining of steel, austenitic stainless steel and cast materials. Due to special chip pimples, very good chip control at low to medium depth of cut and feed rates. Smooth chip evacuation and low cutting forces.

Mittlere Zerspanung

Medium machining
Semifinitura

einseitig
single sided
singolo lato

**- AM**

Geometria di rompitruciolo per la semifinitura di acciaio, acciaio inossidabile austenitico e acciaio da fusione. I rigonfiamenti sulla spoglia superiore aiutano la rottura del truciolo a basse e medie profondità di taglio ed avanzamenti. Ottimo scorporamento del truciolo e ridotte forze di taglio.

- PM1

Neu entwickelte positive Schneidengeometrie für die Schlichtbearbeitung und mittlere Zerspanung. Diese Geometrie eignet sich besonders zur Bearbeitung von Stahl sowie rostfreien Stählen. Die doppelt-positive Schneidkante garantiert eine hohe Prozesssicherheit und eine exzellente Spankontrolle auch bei hohen Vorschüben.

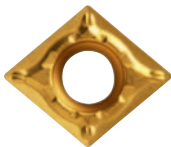
**- PM1**

Newly developed positive geometry for finishing and medium machining. This geometry is mostly suitable for steel and stainless steel. The double positive cutting edge ensures high reliability and excellent swarf evacuation. The wave shaped geometry offers excellent swarf control, even at high feed rates.

Schlicht- und mittlere Zerspanung

Finishing and medium machining
Finitura e medie asportazioni

einseitig
single sided
singolo lato

**- PM1**

Nuova geometria Positiva sviluppata per la finitura o la semifinitura di Acciai legati e Acciai Inossidabili. La particolare forma positiva del rompitruciolo assicura una massima affidabilità della asportazione ed un ottimale controllo del truciolo.

- PMS

Geometrie zum Schlichten bis mittlere Zerspanung von Stahl.

**- PMS**

Geometry for finishing to medium machining of steel.

Schlicht- und mittlere Zerspanung

Finishing and medium machining
Finitura e medie asportazioni

einseitig
single sided
singolo lato

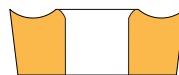
**- PMS**

Geometria per la finitura e semifinitura di acciaio.

- PS

Geometrie für die Feinschlichtbearbeitung von rostfreiem Stahl und warmfesten Legierungen mit geringen Vorschüben und Spantiefen. Kontrollierter Spanbruch. Niedrige Schnittkräfte. Am Umfang geschliffene Wendeschneidplatte. Auch geeignet für die Bearbeitung von NE-Metallen.

**- PS**

Geometry for finishing stainless steels and heat resistant alloys with low feed rates and depth of cut. Controlled chip breaking. Low cutting forces. Periphery ground insert which is also suitable for non-ferrous materials.

Schlichtzerspanung

Finishing
Finitura

einseitig
single sided
singolo lato

**- PS**

Geometria universale per la lavorazione dell'acciaio, acciaio inox e ghisa.

- PS2

Geometrie für die Schlichtbearbeitung zum Erreichen hoher Oberflächengüten und Toleranzgenauigkeiten bei der Zerspanung von Stahl, Stahlguss und rostfreien Stählen. Mini-Spanbrecher für kontrollierten Spanbruch. Scharfe Schneidkante.



- PS2

Geometry for finishing steel, cast steel and stainless steel. Mini chip breaker for controlled chip breaking. Sharp cutting edge.

Schlichtzerspanung

Finishing
Finitura

einseitig
single sided
singolo lato



- PS2

Geometria per la finitura di acciaio, acciaio da fusione ed acciaio inossidabile. Mini rompitruciolo per un miglior controllo. Tagliente positivo.

- ACB

Anwendungsbereich entsprechend der „-ALU“-Geometrie, jedoch mit optimierter Spanform. Zusätzliche Spannoppen für verbesserten Spanbruch und kurze Späne.



- ACB

Same application area as “-ALU” geometry, however with optimized chip breaker. Special chip breaker for small chips.

Mittlere Zerspanung

Medium machining
Semifinitura

einseitig
single sided
singolo lato



- ACB

Geometria con un campo applicativo simile alla geometria “-ALU” ma con rompitruciolo ottimizzato per un controllo trucioli di piccola sezione.

- AEC

Geometrie zum Schlichten von Stahl und rostfreiem Stahl. In unbeschichteter Ausführung auch geeignet für NE-Metalle.



- AEC

Precision sintered geometry for finishing steel and stainless steel. As uncoated version also suitable for non-ferrous materials.

Schlicht- und mittlere Zerspanung

Finishing and medium machining
Finitura e medie asportazioni

einseitig
single sided
singolo lato



- AEC

Geometria sinterizzata di precisione dalla finitura alla sgrossatura di materiali non ferrosi quali Alluminio, leghe di Alluminio, Rame ed Ottone. Nella versione rivestita ottimo per la finitura di acciaio inossidabile.

- ALU

Geometrie für die Bearbeitung von Aluminium und Aluminiumlegierungen sowie Bunt- und Nichteisenmetallen. Auch geeignet für die Feinzerspanung von Molybdän, Sinterstahl oder zum Schlichten von rostfreien Stählen. Geringe Schnittkräfte durch die scharfe Schneidkante in Verbindung mit der speziell ausgelegten Spanleitstufe. Dadurch optimale Bearbeitung von labilen, dünnwandigen Teilen möglich. Wendeschneidplatten komplett umfanggeschliffen.



- ALU

Geometry for machining aluminum/ alloys and non-ferrous materials. Also suitable for finishing molybdenum, sintered steel or stainless steel. Very low cutting forces due to sharp cutting edges and special chip breaker. Excellent machining of unstable and thin-walled workpieces. Completely ground insert.

Mittlere Zerspanung

Medium machining
Semifinitura

einseitig
single sided
singolo lato

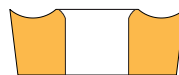

- ALU

Geometria universale per lavorazione di alluminio, leghe di alluminio e materiali non ferrosi. In versione rivestita idonea anche per la finitura di leghe di molibdeno, acciai sinterizzati o acciai inossidabili. Ridotte forze di taglio per la spoglia positiva e rompitruciolo speciale. Ottimo per la lavorazione di pareti sottili o per condizioni gravose. Inserto completamente rettificato.

- ASF

Schlichtgeometrie für die Bearbeitung von Aluminium und Aluminiumlegierungen sowie Bunt- und Nichteisenmetallen. Auch geeignet zum Schlichten von rostfreien Stählen. Geringe Schnittkräfte durch die scharfe Schneidkante in Verbindung mit der speziell ausgelegten Spanleitstufe. Wendeschneidplatte komplett umfanggeschliffen.



- ASF

Finishing geometry for machining aluminum, aluminum alloys and non-ferrous materials. Also suitable for finishing stainless steel. Very low cutting forces due to sharp cutting edges and special chip breaker. Completely ground insert.

Schlichtzerspanung

Finishing
Finitura

einseitig
single sided
singolo lato



- ASF

Geometria di finitura per la lavorazione di materiali non ferrosi, Alluminio, leghe di Alluminio. Idoneo in versione rivestita anche per finitura di acciaio inossidabile. Basse forze di taglio grazie al tagliente molto positivo ed allo speciale vano rompitruciolo. Inserto completamente rettificato.

- AQ

Geometrie für die Schlichtzerspanung von Stahl, Stahlguss und nichtrostenden Stählen. Hohe Oberflächenqualität und Toleranzgenauigkeit. Sehr gute Spanformung.



- AQ

Universal geometry for finishing to medium machining of steel, cast steel and stainless steel. Excellent surface finish and tolerance accuracy. Very good swarf control.

Schlichtzerspanung

Finishing
Finitura

einseitig
single sided
singolo lato



- AQ

Geometria universale per la Finitura e la Semifinitura di acciaio, acciaio da fusione ed acciaio inossidabile. Ottima finitura superficiale e precisione di lavorazione. Eccellente controllo truciolo.

- PMC

Universelle Geometrie für die Bearbeitung von Stahl und Stahlguss, legierten Stählen und nichtrostenden Stählen. Zum Schlichten und für die mittlere Zerspanung geeignet. Guter Spanablauf. In vielen Bearbeitungsbereichen einsetzbar.



- PMC

Universal geometry for machining steel, cast steel, alloyed steel and stainless steel. Suitable for finish to medium machining. Because of the wide chip grooves good chip control is achieved in most applications.

Schlicht- und mittlere Zerspanung

Finishing and medium machining
Finitura e medie asportazioni

einseitig
single sided
singolo lato

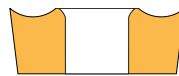

- PMC

Geometria universale per la lavorazione di acciaio, acciaio da fusione, acciai legati ed acciai inossidabili. Applicabile per la finitura e la semifinitura. Grazie all'ampio canale rompitruciolo, ottimo controllo truciolo nella maggior parte delle applicazioni.

- U

Hauptanwendungsbereich in der Stahlzerspanung. Gute Spanlenkung bei geringem Vorschub und unterschiedlichen Schnitttiefen. Geringe Schnittkraft.

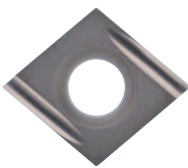

- U

Main application is steel machining. Good chip control at low feed rates and different cutting depths. Low cutting forces.

Schlicht- und mittlere Zerspanung

Finishing and medium machining
Finitura e medie asportazioni

einseitig
single sided
singolo lato



- U

Applicazione ideale nella Truciolatura di Acciaio. Ottimo controllo truciolo ed un taglio con ridotte forze in diverse profondità.

Beschichtet / Coated / Rivestito**AK2110****CVD-Mehrlagenbeschichtung**

Sorte für die Schrumpferspannung von Grauguss und Kugelgraphitguss. Die AK2110 besitzt eine exzellente Verschleißfestigkeit und eine geringe Neigung zur Aufbauschneidenbildung. Für den universellen Einsatz bei der GG- und GGG-Bearbeitung.

CVD-multilayer coating

Grade for roughing of cast iron and nodular cast iron. AK2110 has excellent wear resistance and low tendency for build up edge. For the universal use on grey cast iron and ductile iron.

Rivestimento CVD-multistrato

Qualità per la lavorazione di sgrassatura di Ghisa grigia e Ghisa sferoidale. Grado con una ottima resistenza all'usura per una massima stabilità di taglio.

AK2120**CVD-Mehrlagenbeschichtung**

Für die Schrumpferspannung von Grauguss und Kugelgraphitguss. Die AK2120 besitzt eine exzellente Verschleißfestigkeit und eine geringe Neigung zur Aufbauschneidenbildung. Für den universellen Einsatz bei der GG- und GGG-Bearbeitung.

CVD-multilayer coating

For roughing of cast iron and nodular cast iron. AK2120 has excellent wear resistance and low tendency for build up edge. For the universal use on grey cast iron and ductile iron.

Rivestimento CVD-multistrato

Qualità per la lavorazione di sgrassatura di Ghisa grigia e Ghisa sferoidale. Grado con una ottima resistenza all'usura per una massima stabilità di taglio.

AL136**PVD-Mehrlagenbeschichtung**

Zur Bearbeitung von Stahl, rostfreiem Stahl sowie Stahlguss bei mittleren bis großen Spanquerschnitten und mittleren Schnittgeschwindigkeiten auch unter ungünstigen Bearbeitungsbedingungen.

PVD-multi layer coating

To be used for the machining of steel, stainless steel as well as steel castings with intermediate to large chip sections, medium cutting speeds and under unfavourable conditions.

Rivestimento multistrato PVD

Per la lavorazione di acciaio, acciaio inox e acciaio da fusione per medie e grandi sezioni di truciolo e velocità moderate anche in condizioni di lavoro instabili.

AL160**PVD-Mehrlagenbeschichtung**

Sorte mit sehr guter Verschleißfestigkeit zur Nass- und Trockenbearbeitung von hochfesten Werkzeugstählen, Gusseisen mit Lamellengraphit, Temperguss und Kugelgraphitguss bei hohen Schnittgeschwindigkeiten unter stabilen Bearbeitungsbedingungen. Auch geeignet für die Zerspanung von gehärteten Werkzeugstählen im Formenbau.

PVD-multi layer coating

Grade with very good wear resistance for wet or dry machining of tool steels with high tensile strength, cast iron, cast iron with laminated graphite, malleable cast iron and spheroidal cast iron under stable working conditions. Also suitable for machining hardened mould-tool steel.

Rivestimento multistrato PVD

Qualità con ottima resistenza all'usura per la lavorazione con refrigerante e a secco di acciai, acciai per utensili ad alta resistenza, ghisa con grafite lamellare, ghisa malleabile e ghisa sferoidale ad elevate velocità di taglio in condizioni di lavoro stabili. Adatto anche per la lavorazione di acciai da utensili temprati o acciai stampati.

AL260**PVD-Mehrlagenbeschichtung**

Hartmetallsorte mit guter Verschleißfestigkeit und hoher Zähigkeit zur Nass- und Trockenbearbeitung von Stahlwerkstoffen, warmfesten Legierungen und Kugelgraphitguss bei guten Bearbeitungsbedingungen. Einsatz innerhalb eines großen Schnittgeschwindigkeits- und Spanquerschnittbereiches.

PVD multilayer coating

These are hard metal types with good resistance to wear and great resilience to wet or dry machining of steel materials, heat resistant alloys and spherical graphite casts under normal machining conditions. Used where need broad range of cutting speeds and chip cross sections.

Rivestimento multistrato PVD

Grado con buona resistenza all'usura ed elevata tenacità di lavorazione con refrigerante e secco di materiali quali acciaio, leghe resistenti al calore e ghisa sferoidale, in buone condizioni di lavoro. Utilizzabile all'interno di un grande campo di variabili velocità di taglio e sezione truciolo.

AL360**PVD-Mehrlagenbeschichtung**

Sorte mit sehr hoher Zähigkeit zur Nass- und Trockenbearbeitung von Stahlwerkstoffen mit niedriger bis mittlerer Festigkeit und rostfreiem Stahl bei mittleren Schnittgeschwindigkeiten. Auch bei ungünstigen Bearbeitungsbedingungen einsetzbar.

PVD-multi layer coating

These kinds have a great resilience to wet and dry machining of great materials; with low to medium hardness; and stainless steel at medium cutting speeds. Can be used under prevalent unfavourable machining conditions.

Rivestimento multistrato PVD

Qualità con elevata tenacità per lavorazione con refrigerante e a secco di acciaio con bassa a media resistenza ed acciaio inossidabile a velocità moderata. Ideale per condizioni di lavoro instabili.

AM2035

CVD-Mehrlagenbeschichtung

Für schwer zerspanbare, austenitische rostfreie Stähle und hochwärmefeste Legierungen ist diese Sorte die erste Wahl. Die AM2035 ist auch für legierte und unlegierte Stähle, nichtrostende Stähle sowie Titanlegierungen geeignet. Sie weist eine extrem hohe Zähigkeit und eine sehr gute Verschleißfestigkeit auf.

CVD-multilayer coating

First choice when machining difficult to cut austenitic stainless steel and high temperature alloys. AM2035 is also suitable for alloyed and non-alloyed stainless steel as well as titanium alloys. This grade offers extreme toughness and excellent wear resistance.

Rivestimento CVD-multistrato

Qualità suggerita per la lavorazione di difficili acciai inossidabili austenitici e leghe refrattarie. AM2035 è inoltre idonea a lavorare acciai altamente legati così come quelli debolmente legati o leghe di titanio. Questa qualità offre una maggiore tenacità ma una minore resistenza all'usura della qualità AM2030.

AM2110

CVD-Mehrlagenbeschichtung

Für die Schlichtbearbeitung von rostfreiem Stahl. Durch die sehr harte und mikrofeine Beschichtung ergibt sich eine hohe Standzeit und verbesserte Verschleißfestigkeit.

CVD-multilayer coating

For finishing of stainless steel. The very hard and micro fine coating give a very high tool life and improved wear resistance.

Rivestimento CVD-multistrato

Qualità per la finitura di Acciaio inossidabile e Acciaio legato. Il rivestimento multistrato di elevata durezza con un substrato di metallo duro micrograna garantiscono la resistenza di un tagliente affilato e duro ma allo stesso tempo molto tenace.

AM2130

CVD-Mehrlagenbeschichtung

Hauptsorte für die mittlere und schwere Bearbeitung von rostfreiem Stahl. Durch die sehr harte und mikrofeine Beschichtung ergibt sich eine hohe Standzeit und verbesserte Verschleißfestigkeit. Auch bei unterbrochenen Schnitten geeignet.

CVD-multilayer coating

Main grade for medium to heavy machining of stainless steel. The very hard and micro fine coating give a very high tool life and improved wear resistance. Also suitable for interrupted cut.

Rivestimento CVD-multistrato

Qualità per la asportazione media e pesante di Acciaio Inossidabile. Grazie al rivestimento multistrato molto duro ed il substrato in metallo duro micrograna, garantisce una elevata resistenza all'usura assieme ad una buona tenacità. Idonea anche per i tagli interrotti.

AM26C

CVD-Mehrlagenbeschichtung

Verschleißfeste Sorte mit hoher Schneidkantenstabilität zur Bearbeitung von Stählen höherer Festigkeit mit hohen Schnittgeschwindigkeiten.

CVD-multilayer coating

Wear resistant grade with good cutting edge stability for machining steel with higher hardness, at high cutting speeds.

Rivestimento CVD multi-strato

Qualità resistente all'usura con elevata stabilità del tagliente per lavorazione di acciai di alta resistenza con elevate Velocità di taglio.

AM350

CVD-Mehrlagenbeschichtung

Sorte mit guter Verschleißfestigkeit und sehr guter Zähigkeit zum Bearbeiten von Stahl, rostfreiem Stahl sowie Stahlguss bei mittleren Spanquerschnitten und mittleren bis hohen Schnittgeschwindigkeiten. Einsatz auch unter ungünstigen Bearbeitungsbedingungen. Besonders geeignet für alle austenitischen, rostfreien Stähle.

CVD-multilayer coating

Grade with a good combination of wear resistance and toughness for machining steel, stainless steel as well as cast steel at medium chip-cross-sections and medium to high cutting speeds. Can also be used under unfavourable machining conditions. Special grade for stainless steel (austenitic).

Rivestimento CVD multistrato

Grado con buona resistenza all'usura ed eccellente tenacità per la lavorazione di acciaio, acciaio inox e acciaio da fusione con medie sezioni truciolo e medio-alte velocità di taglio. Utilizzare anche in sfavorevoli condizioni di lavorazione. Particolarmente indicato per tutti gli acciai inossidabili austenitici.

AM36C

CVD-Mehrlagenbeschichtung

Sorte mit sehr hoher Zähigkeit für die Nass- und Trockenbearbeitung von Stahl niedriger bis mittlerer Festigkeit, austenitischem rostfreiem Stahl bei mittleren Schnittgeschwindigkeiten, auch bei ungünstigen Bearbeitungsbedingungen.

CVD-multilayer coating

Grade with very high toughness for machining (with or without coolant) steel with low to medium hardness, stainless steel (austenitic), at medium cutting speeds, also under unfavourable machining conditions.

Rivestimento CVD multistrato

Qualità con elevata tenacità per lavorazione con refrigerante e a secco di acciaio a bassa/media resistenza, acciaio inossidabile austenitico a velocità moderata, anche in condizioni di lavoro instabili.

AM5025

PVD-Mehrlagenbeschichtung

Optimale Sorte für die Bearbeitung von rostfreien Stählen, warmfesten Stählen und Titan (Legierungen) bei der Schlicht- bis mittleren Bearbeitung. Die AM5025 weist eine sehr gute Zähigkeit und eine gute Verschleißfestigkeit auf. Sie ist auch für wechselnde Schnitttiefen und unterbrochene Schnitte geeignet.

PVD-multilayer coating

Ideal grade for finish to medium machining of stainless steel, temperature resistant steel and titanium (alloys). AM5025 has very good toughness and good wear resistance and can be used both at varied cutting depth and interrupted cutting.

Rivestimento PVD-multistrato

Qualità ideale per la finitura e semi-finitura di acciaio inossidabile, leghe refrattarie ed esotiche e leghe di titanio. AM5025 ha una ottima tenacità combinata ad una ottima resistenza all'usura e può essere utilizzato con profondità di passata variabili e con taglio interrotto.

AM5040

PVD-Mehrlagenbeschichtung

Eine zähe, universell einsetzbare Sorte für niedrige und mittlere Schnittgeschwindigkeiten. Hauptanwendungsbereich für rostfreie Stähle sowie für die Stahlbearbeitung. Gute Prozesssicherheit sowie beständig gegen Schneidkantenausbrüche.

PVD-multilayer coating

A tough but universal grade for low to medium cutting speeds. The main application area being stainless steel and steel.

Rivestimento PVD-multistrato

Qualità univesale per velocità medio basse. Campo di applicazione principale acciai e acciai inossidabili. Notevole robustezza e resistenza alla scheggiatura.

AM5110

PVD-Mehrlagenbeschichtung

Sorte zur Feinbearbeitung von VA-Stählen, Nickel- und Titanlegierungen und exotischen Werkstoffen. Bearbeitung abrasiver und naturharter Werkstoffe wie CoCrMo oder Hartguss.

PVD-multilayer coating

Grade for finish machining of stainless steel, nickel and titanium alloys as well as exotic materials. Also for abrasive and hard materials such as CoCrMo and chilled cast iron.

Rivestimento PVD-multistrato

Qualità sviluppata per la lavorazione di precisione di acciai inossidabili, leghe di Nickel, leghe di Titanio, e materiali esotici. Ottima per la lavorazione di materiali abrasivi e duri come leghe Co, Cr, Mo o ghise dure.

AM5120

PVD-Mehrlagenbeschichtung

Sorte für die Schruppbearbeitung von rostfreien Stählen, auch besonders geeignet für exotische Materialien, hitzebeständige Legierungen und Titanlegierungen.

PVD-multilayer coating

The grade for roughing stainless steel and machining of exotic and heat resistant materials as well as titanium alloys.

Rivestimento PVD-multistrato

Grado per la sgrossatura di acciai inossidabili, particolarmente adatti per materiali esotici, leghe resistenti al calore e leghe di titanio.

AM5635

PVD-Mehrlagenbeschichtung

Hauptanwendungsbereich für rostfreie Stähle. In der Nebenanwendung ist diese Sorte für die Bearbeitung von Stahlwerkstoffen geeignet. Aufgrund der PVD-Beschichtung geringe Neigung zur Bildung einer Aufbauschneide.

PVD-multilayer coating

The main application area being stainless steel. It is also very suitable for machining steel. Because of PVD-coating very little tendency for build up edge.

Rivestimento PVD-multistrato

Campo di applicazione principale acciai inossidabili. E' inoltre idoneo ad alcune lavorazioni di acciai. Il rivestimento PVD riduce la formazione del tagliente di riporto.

AP1530

Hauptanwendung bei Stahl und rostfreien Stählen. In der Nebenanwendung auch für Aluminium und nichtmetallische Werkstoffe geeignet. Bei normalen Rahmenbedingungen für mittlere- bis hohe Schnittgeschwindigkeiten. Diese Sorte ist aber auch bei ungünstigen Bearbeitungsbedingungen zu empfehlen.

Main application for steel and stainless steel.

Can also be used on aluminium and non-ferrous materials. Under good conditions to be used at medium to high cutting speeds. This grade is also recommended for unstable cutting conditions.

Utilizzo principale per lavorazione di acciai e acciai inossidabili. Adatto limitatamente anche per materiali non ferrosi, alluminio e materiali non metallici. Da utilizzare in condizioni normali di lavoro con medio-alte velocità di taglio. Idonea anche per condizioni di lavoro instabili.

AP2025

CVD-Mehrlagenbeschichtung

Diese vielseitige Sorte zeichnet sich durch ihr breites Einsatzspektrum bei allen Stahlwerkstoffen und Gusswerkstoffen aus. Sie ist ebenfalls für rostfreien Stahl geeignet. Durch ihre hohe Zähigkeit und hohe Verschleißfestigkeit ist sie die optimale Universalschneidplatte für Ihre Fertigung.

CVD-multilayer coating

This multi purpose grade excels due to its versatile application area in steel and cast materials. It is also very suitable for machining stainless steel, heat resistant alloys and titanium alloys. Because of its high toughness and wear resistance this is the optimum general purpose grade for your production.

Rivestimento CVD-multistrato

Qualità universale per svariati campi applicativi nella lavorazione di acciaio e materiali da fusione. E' inoltre idoneo ad alcune lavorazioni di acciaio inossidabile, leghe refrattarie e leghe di titanio. Grazie alla buona tenacità combinata ad una ottima resistenza all'usura risulta essere la qualità ottimale per le generiche lavorazioni della vostra produzione.

AP2035

CVD-Mehrlagenbeschichtung

Bei ungünstigen Schnittbedingungen, wie unterbrochenem Schnitt, labilen Verhältnissen oder nicht optimalen Materialoberflächen bei Stahlwerkstoffen, ist diese Sorte die erste Wahl. Ebenso kann die AP2035 bei rostfreien Stählen eingesetzt werden. Sie zeichnet sich durch eine extrem hohe Zähigkeit und eine gute Verschleißfestigkeit aus.

CVD-multilayer coating

When the cutting conditions are poor, interrupted cutting, unstable conditions or poor material surface quality, the grade AP2035 is your first choice. It can also be used in stainless steel. This grade has extreme high toughness and good wear resistance.

Rivestimento CVD-multistrato

Qualità suggerita in lavorazioni instabili, gravose, con taglio interrotto o su superfici grezze. Può essere utilizzata anche per la lavorazione di acciaio inossidabile dove è richiesta tenacità. Questa qualità ha un'elevata tenacità con la giusta combinazione di resistenza all'usura.

AP2110

CVD-Mehrlagenbeschichtung

Premium-Sorte für die „High Speed“-Bearbeitung von Stahl. Auch geeignet für die Schrumpfbearbeitung von Grauguss und Kugelgraphitguss. Hier garantiert sie höchste Sicherheit, auch unter extremen Bedingungen.

CVD-multilayer coating

Premium grade for "high speed" machining of steel. Also suitable for roughing of cast iron and nodular cast iron.

Rivestimento CVD-multistrato

Qualità per la lavorazione ad alta velocità di taglio di Acciaio. Adatto anche per la lavorazione di Ghisa Grigia e Ghisa Sferoidale. Qualità che garantisce la massima affidabilità in condizioni estreme di lavoro.

AP2120

CVD-Mehrlagenbeschichtung

Universelle Mehrbereichssorte für die Schlicht und mittlere Zerspanung von Stahlwerkstoffen. Auch für leicht bis stark unterbrochenen Schnitt geeignet. Hervorragende Beständigkeit gegen plastische Verformung und Ausbrüche. Das legierte Hartmetallsubstrat mit einer neuartigen, extrem fein strukturierten Aluminiumoxidschicht sorgt für eine hohe thermische Beständigkeit und eine exzellente Schichthaftung.

CVD-multilayer coating

Grade for finishing and medium machining of steel in both uninterrupted and heavy interrupted cutting conditions. Excellent resistance to plastic deformation as well as fracturing. The alloyed carbide substrate with a fine grained aluminium oxide coating ensures high thermal resistance and excellent coating structure.

Rivestimento CVD-multistrato

Qualità universale per le lavorazioni generiche di Acciaio di finitura e semi-finitura. Adatta anche per lavorazioni a taglio interrotto. Eccellente resistenza alla deformazione plastica e alla craterizzazione. Ottima resistenza all'usura grazie al substrato micrograna e a rivestimenti multistrato di Ossido di Alluminio che garantiscono ottima dissipazione del calore.

AP2125

Hauptanwendung für Stahl und Gusswerkstoffen. In der Nebenanwendung auch für rostfreie Stähle und exotische Werkstoffe geeignet. Die AP2125 zeichnet sich durch eine hohe Verschleißfestigkeit, eine hohe Zähigkeit und eine gute Temperaturbeständigkeit – auch bei wechselnden Temperaturen – aus. Bei normalen Rahmenbedingungen für mittlere- bis hohe Schnittgeschwindigkeiten.

Main application for steel and cast materials.

Can also be used for stainless steel and exotic materials. AP2125 is very wear resistant, high toughness and good resistance to varied temperature. Under normal conditions to be applied at medium to high cutting data.

Utilizzo principale per lavorazioni di acciaio e ghisa. Adatto anche limitatamente per acciai inossidabili e materiali esotici. La qualità AP2125 è caratterizzata da una elevata resistenza all'usura, elevata tenacità e buona resistenza alle alte temperature. Utilizzabile in condizioni normali di lavoro con medio-alte velocità di taglio.

AP2310

CVD-Mehrlagenbeschichtung

Nachfolgesorte für AP2110. Hauptsorte für die Stahlzerspanung im Bereich Schlichten. Neuer Beschichtungsaufbau ermöglicht höhere Verschleißfestigkeit und somit höhere Standzeiten.

CVD-multilayer coating

Replacement grade for AP2110. Grade for finishing steel. New coating technology offers less wear and longer tool life.

Rivestimento CVD-multistrato

Qualità per la finitura di acciaio. La nuova tecnologia di rivestimento garantisce una maggiore resistenza all'usura ed una incrementata vita inserto.

AP2320

CVD-Mehrlagenbeschichtung

Nachfolgesorte für AP2120. Hauptsorte für die Stahlzerspanung – gegen plastische Deformation mit hoher Bruchfestigkeit für den Bereich mittlere Zerspanung.

CVD-multilayer coating

Replacement grade for AP2120. Grade for cutting steel. Coating against plastic deformation with high tensile strength for medium machining.

Rivestimento CVD-multistrato

Qualità specifica per la semifinitura di acciaio. Tenace, resistente alle rotture e alla deformazione plastica causata dalle elevate temperature.

AP2335

CVD-Mehrlagenbeschichtung
Nachfolgesorte für AP2135. Hauptsorte für die Stahlzerspannung – extrem zähe Sorte für unterbrochene Schnitte und ungünstige Bedingungen im Bereich Schruppen.

CVD-multilayer coating
Replacement grade for AP2135. Grade for cutting steel. Extremely tough grade for interrupted cuts and unfavorable machining conditions in roughing applications.

Rivestimento CVD-multistrato
Qualità per la sgrossatura di Acciaio. Estremamente resistente al taglio interrotto ed in condizioni instabili di lavoro.

AP5020

PVD-Mehrlagenbeschichtung
Universelle Sorte für die allgemeine Stahlzerspannung. Auch geeignet für die Bearbeitung rostfreier Stähle, warmfester Legierungen sowie Titanlegierungen. Sehr gute Warmfestigkeit.

PVD-multilayer coating
Suitable for general steel cutting, but also suitable for machining stainless steel, high temperature alloys as well as titanium alloys. Very good heat resistance.

Rivestimento PVD-multistrato
Grado di metallo duro per lavorazioni di acciai, di acciai INOX, leghe fortemente legate o resistenti al calore così come leghe di Titanio. Elevata resistenza al calore.

AP5030

PVD-Mehrlagenbeschichtung
Eine universell einsetzbare Sorte im Bereich P30-P35. Hauptanwendungsbereich für die Stahlbearbeitung, Nebenanwendung für rostfreie Stähle.

PVD-multilayer coating
A universal grade mainly for steel applications. The slightly tougher substrate (ISO P30-P35) makes it suitable also for stainless steel.

Rivestimento PVD-multistrato
Qualità molto versatile su campo iso P30-P35 per lavorazioni in sicurezza. Ottima per la lavorazione di acciai in condizioni non perfette di lavoro. Secondaria scelta per acciai inossidabili.

AP5635

PVD-Mehrlagenbeschichtung
Hauptanwendungsbereich für Stahlwerkstoffe. In der Nebenanwendung ist diese Sorte für die Bearbeitung von rostfreien Stählen geeignet. Aufgrund der PVD-Beschichtung geringe Neigung zur Bildung einer Aufbauschneide.

PVD-multilayer coating
The main application area being steel. It is also very suitable for machining stainless steel. Because of PVD-coating very little tendency for build up edge.

Rivestimento PVD-multistrato
Campo di applicazione principale acciai. E' inoltre idoneo ad alcune lavorazioni di acciai inossidabili. Il rivestimento PVD riduce la formazione del tagliente di riporto.

AR16C

CVD-Mehrlagenbeschichtung
Sorte mit guter Verschleißfestigkeit und Zähigkeit zur Bearbeitung von Grauguss, Gusseisen mit Lamellengraphit, Temperguss und Kugelgraphitguss bei hohen Schnittgeschwindigkeiten und mittleren Spanquerschnitten.

CVD-multilayer coating
Grade with good wear resistance and toughness for machining grey cast iron, cast iron with laminated graphite, malleable cast iron and spheroidal cast iron at high cutting speeds and medium chip-cross sections.

Rivestimento CVD multistrato
Grado con buona resistenza all'usura e tenacità per la lavorazione di ghisa, ghisa con grafite lamellare, malleabile e ghisa sferoidale ad elevate velocità di taglio e sezioni medie di truciolo.

AR26C

CVD-Mehrlagenbeschichtung
Hartmetallsorte mit guter Verschleißfestigkeit und hoher Zähigkeit zur Nass- und Trockenbearbeitung von Stahl, austenitischem rostfreiem Stahl, warmfesten Legierungen, Kugelgraphitguss und HSS auch unter weniger guten Bearbeitungsbedingungen. Einsatz innerhalb eines großen Schnittgeschwindigkeits- und Spanquerschnittsbereiches.

CVD-multilayer coating
Grade with good wear resistance and high toughness for machining (with or without coolant) steel, stainless steel (austenitic), heat-resistant alloys, spheroidal cast iron and HSS, also under less stable machining conditions. Can be used at a wide range of cutting speeds and chip-cross-sections.

Rivestimento CVD multistrato
Grado con buona resistenza all'usura ed elevata tenacità di lavorazione con refrigerante e a secco di acciaio austenitico, acciaio inox, leghe resistenti al calore, ghisa sferoidale e ad alta velocità anche in condizioni di lavoro meno favorevoli. Utilizzare all'interno di un grande campo variabile di velocità di taglio e la sezione truciolo.

ISO	Hartmetall beschichtet Carbide coated Metallo duro rivestito	Schneidstoff Cutting material Materiale da taglio	Anwendung Application Parametri
P Stahl, Stahlguss, langspannender Temperguss <i>Steel, cast steel, malleable iron</i> Acciaio, acciaio da fusione, ghisa malleabile da truciolo lungo	AK2110, AK2120, AL136, AL260, AL360, AM2035, AM26C, AM350, AM35C, AM36C, AM5040, AM5635, AP1530, AP2025, AP2030, AP2035, AP2110, AP2120, AP2125, AP2310, AP2320, AP2335, AP5020, AP5030, AP5635, AR26C, AR270, AR370	Zähigkeit Toughness / Tenacità Verschleißbeständigkeit / Wear resistance / Resistenza all'usura	Vorschub Feed rate / Avanzamento Schnittgeschwindigkeit Cutting speed / Velocità di taglio
M Rostfreier Stahl, Stahlguss, Manganstahl, Automatenstahl <i>Stainless steel, cast steel, manganese steel, free cutting steel</i> Acciaio inossidabile, Acciaio da Fusione, Acciaio al Manganese, Acciaio Automatico	AL136, AL260, AL360, AM2030, AM2035, AM2130, AM26C, AM350, AM35C, AM36C, AM5040, AM5025, AM5110, AM5120, AM5635, AP2025, AP2030, AP2035, AP5020, AP5030, AP5635, AR270, AR370	Zähigkeit Toughness / Tenacità Verschleißbeständigkeit / Wear resistance / Resistenza all'usura	Vorschub Feed rate / Avanzamento Schnittgeschwindigkeit Cutting speed / Velocità di taglio
K Grauguss, Kokillenhartguss, kurzspannender Temperguss <i>Grey cast iron, chilled hard cast iron, short chipping malleable iron</i> Ghisa grigia, ghisa sferoidale, ghisa malleabile a truciolo corto	AK2110, AK2120, AL160, AL260, AM5110, AM5120, AP1530, AP2025, AP2030, AP2110, AP2125, AR16C, AR26C, AR270	Zähigkeit Toughness / Tenacità Verschleißbeständigkeit / Wear resistance / Resistenza all'usura	Vorschub Feed rate / Avanzamento Schnittgeschwindigkeit Cutting speed / Velocità di taglio
N Aluminium und Al-Legierungen, nicht-metallische Werkstoffe <i>Aluminum and Al-alloys, non-ferrous materials</i> Alluminio e sue leghe, materiali non ferrosi o non metallici	AM5110, AM5120, AR16C	Zähigkeit Toughness / Tenacità Verschleißbeständigkeit / Wear resistance / Resistenza all'usura	Vorschub Feed rate / Avanzamento Schnittgeschwindigkeit Cutting speed / Velocità di taglio
S Warmfeste Legierungen, Titanlegierungen <i>High temperature resistant alloys, titanium alloys</i> Leghe refrattarie, leghe esotiche, leghe di titanio	AM2030, AM2035, AM5025, AM5110, AM5120, AP5020, AP5210	Zähigkeit Toughness / Tenacità Verschleißbeständigkeit / Wear resistance / Resistenza all'usura	Vorschub Feed rate / Avanzamento Schnittgeschwindigkeit Cutting speed / Velocità di taglio
H Gehärteter Stahl, Hartguss <i>Hardened steel, hard cast iron</i> Acciaio temprato, ghisa temprata	AM5110, AM5120	Zähigkeit Toughness / Tenacità Verschleißbeständigkeit / Wear resistance / Resistenza all'usura	Vorschub Feed rate / Avanzamento Schnittgeschwindigkeit Cutting speed / Velocità di taglio

Hauptanwendungsbereich / Main application area / Applicazione principale

Nebenanwendungsbereich / Secondary application area / Applicazione secondaria

AM5025 - Sorte / Grade / Qualità
Empfohlener Anwendungsbereich / Recommended application area / Applicazione consigliata

AM5025 - Sorte / Grade / Qualità
Empfohlener Anwendungsbereich / Recommended application area / Applicazione consigliata

5

Unbeschichtet / Uncoated / Non rivestito**AK05F**

Verschleißfeste Sorte zur Bearbeitung von Grauguss, Al-Legierungen, Kupfer und NE-Metallen.

Wear resistant grade for machining grey cast iron, Al-alloys, copper and non-ferrous metals.

Grado resistente all'usura per la lavorazione di ghisa grigia, leghe di alluminio, rame e metalli non ferrosi.

AK10F

Verschleißfeste Sorte zur Bearbeitung von Grauguss, Al-Legierungen, Kupfer und NE-Metallen bei mittleren Schnittgeschwindigkeiten und geringen Spanquerschnitten.

Wear resistant grade for machining grey cast iron, Al-alloys, copper and non-ferrous metals at medium cutting speeds and small chip-cross-sections.

Grado resistente all'usura per la lavorazione di ghisa grigia, leghe di alluminio, rame e metalli non ferrosi a velocità moderate e piccole sezioni di truciolo.

AK20F

Hartmetallsorte mit höherer Zähigkeit als AK10 zur Bearbeitung sämtlicher Gusswerkstoffe, Titan und Titan-Legierungen und gehärteten Stählen bis 55 HRC bei mittleren Spanquerschnitten unter ungünstigen Bearbeitungsbedingungen, wie z. B. unterbrochene Schnitte.

Carbide grade with higher toughness as AK10 for machining all cast iron materials, Ti and Ti-alloys and hardened materials up to 55 HRC at medium chip-cross-sections under unfavourable machining conditions and interrupted cuts.

Grado con durezza superiore a AK10 per la lavorazione di tutti i materiali di colata, titanio e leghe di titanio e acciai temprati fino a 55 HRC a sezioni truciolo medie, in condizioni di lavoro instabili, come ad esempio taglio interrotto.

AP20F

Sorte mit hoher Zähigkeit zur Bearbeitung von Stahl im mittleren Schnittgeschwindigkeitsbereich. Einsatz auch unter ungünstigen Bearbeitungsbedingungen.

Grade with high toughness for machining steel at medium cutting speeds. Can also be used under unfavourable cutting conditions.

Grado con alta tenacità per la lavorazione di acciaio a velocità di taglio medio. Utilizzare anche in condizioni di lavoro instabili.

AP40F

Sorte mit höchster Zähigkeit zur Bearbeitung von Stahl und Stahlguss bei mittleren bis hohen Vorschüben und niedrigen Schnittgeschwindigkeiten, auch unter sehr ungünstigen Bearbeitungsbedingungen.

Grade with highest toughness for machining steel and cast steel at medium to high feed rates and low cutting speeds, also under unfavourable machining conditions.

Grado con la più alta tenacità per la lavorazione di acciaio e acciaio da fusione a medio-alte velocità di taglio e avanzamenti bassi, anche in condizioni di lavoro molto sfavorevoli.

AK1010

Hartmetallsorte für die Bearbeitung von sämtlichen Gusswerkstoffen, Aluminium und Aluminiumlegierungen, Kupfer- und Kupferlegierungen sowie Bronze und Messing bei mittleren Spanquerschnitten und unter günstigen Bearbeitungsbedingungen.

Carbide grade for machining of all cast materials, aluminum and aluminum alloys, copper and copper alloys, bronze and brass as well as refractory metals (e.g. niob, tantalum, titanium, molybdenum, tungsten) at medium chip cross sections and at favorable cutting conditions.

Grado di Metallo duro per la lavorazione dei seguenti materiali da fusione: alluminio, leghe di alluminio, rame, leghe di rame, bronzo, ottone così come limitatamente leghe refrattarie (a base di tantalio, niobio, titanio, molibdeno, tungsteno) a medie sezioni truciolo ed in condizioni favorevoli di lavorazione.

AK1020

Optimale Sorte bei der Schlichtbearbeitung von Nicht-Eisen-Metallen wie Aluminium (und Aluminiumlegierungen), Kupfer (und Legierungen), Bronze, Messing und nicht-metallischen Werkstoffen bei glattem Schnitt und/oder leicht wechselnden Schnitttiefen.

Ideal grade for finishing of non-ferrous materials such as aluminum (and aluminum alloys), copper (and alloys), bronze, brass and non metallic materials with a smooth cut and/or light varying cutting depths.

Grado di Metallo duro ideale per la finitura di materiali non ferrosi quali alluminio e le sue leghe, rame e le sue leghe, bronzo, ottone, materiali non metallici con taglio dolce e con minime variazioni di profondità di passata.

ISO	Hartmetall unbeschichtet Carbide uncoated Metallo duro non rivestito	Schneidstoff Cutting material Materiale da taglio	Anwendung Application Parametri
P Stahl, Stahlguss, langspanender Temperguss <i>Steel, cast steel, malleable iron</i> Acciaio, acciaio da fusione, ghisa malleabile da truciolo lungo	10 20 AP20F 30 AP40F 40 50	Zähigkeit Toughness / Tenacità Verschleißbeständigkeit / Wear resistance / Resistenza all'usura	Vorschub Feed rate / Avanzamento Schnittgeschwindigkeit Cutting speed / Velocità di taglio
M Rostfreier Stahl, Stahlguss, Manganstahl, Automatenstahl <i>Stainless steel, cast steel, manganese steel, free cutting steel</i> Acciaio Inossidabile, Acciaio da Fusione, Acciaio al Manganese, Acciaio Automatico	10 20 AP20F 30 AP40F 40 50	Zähigkeit Toughness / Tenacità Verschleißbeständigkeit / Wear resistance / Resistenza all'usura	Vorschub Feed rate / Avanzamento Schnittgeschwindigkeit Cutting speed / Velocità di taglio
K Grauguss, Kokillenhartguss, kurzspanender Temperguss <i>Grey cast iron, chilled hard cast iron, short chipping malleable iron</i> Ghisa grigia, ghisa sferoidale, ghisa malleabile a truciolo corto	10 AK05F AK10F 20 AK20F AK1010 AK1020 30 40 50	Zähigkeit Toughness / Tenacità Verschleißbeständigkeit / Wear resistance / Resistenza all'usura	Vorschub Feed rate / Avanzamento Schnittgeschwindigkeit Cutting speed / Velocità di taglio
N Aluminium und Al-Legierungen, nichtmetallische Werkstoffe <i>Aluminum and Al-alloys, non-ferrous materials</i> Alluminio e sue leghe, materiali non ferrosi o non metallici	10 AK05F AK10F 20 AK20F AK1010 AK1020 30 40 50	Zähigkeit Toughness / Tenacità Verschleißbeständigkeit / Wear resistance / Resistenza all'usura	Vorschub Feed rate / Avanzamento Schnittgeschwindigkeit Cutting speed / Velocità di taglio
S Warmfeste Legierungen, Titanlegierungen <i>High temperature resistant alloys, titanium alloys</i> Leghe refrattarie, leghe esotiche, leghe di titanio	10 20 30 40 50	Zähigkeit Toughness / Tenacità Verschleißbeständigkeit / Wear resistance / Resistenza all'usura	Vorschub Feed rate / Avanzamento Schnittgeschwindigkeit Cutting speed / Velocità di taglio
H Gehärteter Stahl, Hartguss <i>Hardened steel, hard cast iron</i> Acciaio temprato, ghisa temprata	10 20 AK20F 30 40 50	Zähigkeit Toughness / Tenacità Verschleißbeständigkeit / Wear resistance / Resistenza all'usura	Vorschub Feed rate / Avanzamento Schnittgeschwindigkeit Cutting speed / Velocità di taglio

Hauptanwendungsbereich / Main application area / Applicazione principale

Nebenanwendungsbereich / Secondary application area / Applicazione secondaria



Maximale Schnittleistung und minimaler Verschleiß. Vollhartmetall-Schaftfräser für die Bearbeitung nahezu aller gängigen Materialien.

*Great performance and minimal wear
for machining all materials.*

Massime prestazioni di taglio con minima usura.
Frese in metallo duro per la lavorazione
dei principali materiali comuni.



ARNO® VHM-SCHAFTFRÄSER

Ausgezeichnete Verschleißfestigkeit und sehr hohe Standzeiten zeichnen die ARNO Vollhartmetall-Schaftfräser aus. Sie können unterschiedliche Ausführungen für die verschiedensten Materialien wie Stahl, Guss, Aluminium oder exotische Materialien passend zu Ihrer Anwendung auswählen.

The Arno range of solid carbide milling cutters have tools especially suitable for steel, hardened steel, aluminium and exotic materials, all delivering excellent tool life and performance.

L'ampia gamma di frese in Metallo Duro ARNO contempla prodotti dalla eccellente resistenza all'usura ed elevata durata. Diverse tipologie disponibili per una varietà di materiali come acciaio, acciaio legato, alluminio, materiali esotici o per la vostra specifica applicazione.

Weitere ARNO Highlights finden Sie unter:

For further ARNO highlights please see:

Per ulteriori informazioni visitate il nostro sito:

www.arno.de

Wendeschneidplatten – Hartmetall

Indexable inserts – Carbide

Inserti a fissaggio meccanico – Metallo duro

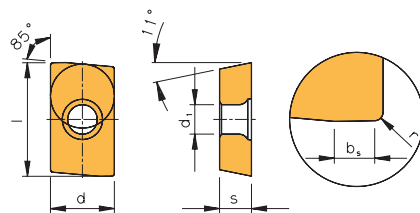

AP..

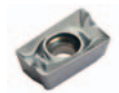
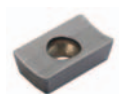

Bezeichnung Designation Articolo	l	d	s	d ₁	r	b _s
APFT 1604PDFR	17,0	9,52	4,76	4,4	0,8	1,9
APFT 1604PDSR	17,0	9,52	4,76	4,4	0,8	1,9
APHT 1604PDSR	17,0	9,52	4,76	4,4	0,8	-
APKT 1003PDER	10,5	6,70	3,50	2,85	0,5	1,2
APKT 1604PDER	16,3	9,45	5,26	4,4	0,8	2,5
APKT 1003PDER-PRS	10,5	6,70	3,50	2,8	0,5	-
APKT 1604PDER-PRS	17,0	9,45	5,26	4,4	0,8	-
APKT 1003PDER-S	10,5	6,70	3,50	2,8	0,5	-
APKT 1604PDER-S	17,0	9,45	5,26	4,4	0,8	-
APKT 1003PDER-U	10,5	6,70	3,50	2,8	0,5	-
APKT 1604PDER-U	17,0	9,45	5,26	4,4	0,8	-

Sorten / Grades / Gradi													
beschichtet/coated/rivestito										unbeschichtet/ uncoated/non rivestito			
AK2110	AK2120	AM26C	AM36C	AM5040	AR16C	AR26C	AP2120	AP5020	AP5030	AK10F	AP20F	AP40F	Bezeichnung Designation Articolo
			●			●				●			APFT 1604PDFR APFT 1604PDSR
						●							APHT 1604PDSR
		●	●		●					●	●	●	APKT 1003PDER APKT 1604PDER
●				●			●		●				APKT 1003PDER-PRS APKT 1604PDER-PRS
			●	●									APKT 1003PDER-S APKT 1604PDER-S
	●							●	●				APKT 1003PDER-U APKT 1604PDER-U
P	○	○	●	●	○		●	●	●		●	●	P
M		○	●	●					○		○	○	M
K	●	●				●	○			●			K
N						○				●			N
S								●					S
H													H

- Hauptanwendung
Main application
Applicazione principale
- Nebenanwendung
Secondary application
Applicazione secondaria

Wendeschneidplatten – Hartmetall

Indexable inserts – Carbide

Inserti a fissaggio meccanico – Metallo duro

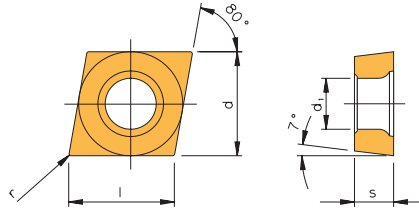

CC..

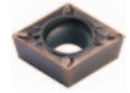
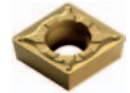
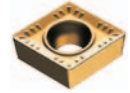
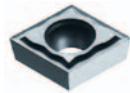

Bezeichnung
Designation
Articolo

	l	d	s	d ₁	r
CCGT 0602005FN-PS	6,45	6,350	2,38	2,8	0,05
CCGT 060201FN-PS	6,45	6,350	2,38	2,8	0,1
CCGT 060202FN-PS	6,45	6,350	2,38	2,8	0,2
CCGT 060204FN-PS	6,45	6,350	2,38	2,8	0,4
CCGT 09T3005FN-PS	9,67	9,525	3,97	4,4	0,05
CCGT 09T301FN-PS	9,67	9,525	3,97	4,4	0,1
CCGT 09T302FN-PS	9,67	9,525	3,97	4,4	0,2
CCGT 09T304FN-PS	9,67	9,525	3,97	4,4	0,4
CCMT 060202EN-AM	6,45	6,350	2,38	2,8	0,2
CCMT 060204EN-AM	6,45	6,350	2,38	2,8	0,4
CCMT 060208EN-AM	6,45	6,350	2,38	2,8	0,8
CCMT 09T302EN-AM	9,67	9,525	3,97	4,4	0,2
CCMT 09T304EN-AM	9,67	9,525	3,97	4,4	0,4
CCMT 09T308EN-AM	9,67	9,525	3,97	4,4	0,8
CCMT 120404EN-AM	12,90	12,700	4,76	5,5	0,4
CCMT 120408EN-AM	12,90	12,700	4,76	5,5	0,8
CCMT 060202EN-PM1	6,45	6,350	2,38	2,8	0,2
CCMT 060204EN-PM1	6,45	6,350	2,38	2,8	0,4
CCMT 09T302EN-PM1	9,67	9,525	3,97	4,4	0,2
CCMT 09T304EN-PM1	9,67	9,525	3,97	4,4	0,4
CCMT 09T308EN-PM1	9,67	9,525	3,97	4,4	0,8
CCMT 120404EN-PM1	12,90	12,700	4,76	5,5	0,4
CCMT 120408EN-PM1	12,90	12,700	4,76	5,5	0,8
CCMT 060202EN-PS2	6,45	6,350	2,38	2,8	0,2
CCMT 060204EN-PS2	6,45	6,350	2,38	2,8	0,4
CCMT 09T302EN-PS2	9,67	9,525	3,97	4,4	0,2
CCMT 09T304EN-PS2	9,67	9,525	3,97	4,4	0,4

Sorten / Grades / Gradi															
beschichtet/coated/rivestito											unbeschichtet/ uncoated/non rivestito		Bezeichnung Designation Articolo		
AK2110	AM2110	AM2130	AM5025	AM5110	AM5120	AP2110	AP2120	AP2310	AP2320	AP2335	AK1010	AK1020			
			●								●	●	CCGT 0602005FN-PS		
			●									●	●	CCGT 060201FN-PS	
			●								●	●	●	CCGT 060202FN-PS	
			●								●	●	●	CCGT 060204FN-PS	
			●								●	●	●	CCGT 09T3005FN-PS	
			●								●	●	●	CCGT 09T301FN-PS	
			●								●	●	●	CCGT 09T302FN-PS	
			●								●	●	●	CCGT 09T304FN-PS	
		●			●			●	●	●				CCMT 060202EN-AM	
		●			●			●	●	●				CCMT 060204EN-AM	
		●			●			●	●	●				CCMT 060208EN-AM	
		●		●	●			●	●	●				CCMT 09T302EN-AM	
		●		●	●			●	●	●				CCMT 09T304EN-AM	
		●		●	●			●	●	●				CCMT 09T308EN-AM	
		●		●	●			●	●	●				CCMT 120404EN-AM	
		●		●	●			●	●	●				CCMT 120408EN-AM	
●		●		●	●	●	●							CCMT 060202EN-PM1	
●		●		●	●	●	●		●	●				CCMT 060204EN-PM1	
		●		●	●	●	●		●	●				CCMT 09T302EN-PM1	
●	●	●		●	●	●	●							CCMT 09T304EN-PM1	
●		●		●	●	●	●							CCMT 09T308EN-PM1	
		●		●	●	●	●						●	CCMT 120404EN-PM1	
		●		●	●	●	●		●					CCMT 120408EN-PM1	
		●		●	●	●	●		●	●				CCMT 060202EN-PS2	
		●		●	●	●	●		●	●				CCMT 060204EN-PS2	
		●		●	●	●	●		●	●				CCMT 09T302EN-PS2	
		●		●	●	●	●		●	●				CCMT 09T304EN-PS2	
P	○			○	○	●	●	●	●	●				P	● Hauptanwendung Main application Applicazione principale
M		●	●	●	●									M	
K	●			○	○	○					○	○		K	○ Nebenanwendung Secondary application Applicazione secondaria
N				○	○						●	●		N	
S			●	●	●									S	
H				○	○									H	



Wendeschneidplatten – Hartmetall

Indexable inserts – Carbide

Inserti a fissaggio meccanico – Metallo duro

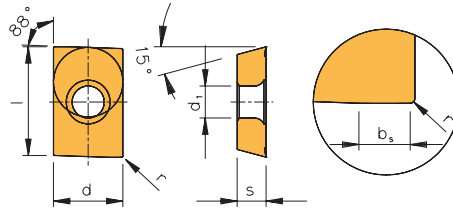

LD..

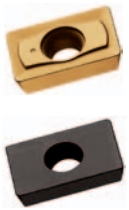

Bezeichnung Designation Articolo	l	d	s	d ₁	r	b _s	Sorten / Grades / Gradi		
							beschichtet/coated/rivestito		unbeschichtet/ uncoated/ non rivestito
							AM36C	AR26C	AK10F
LDHT 15T308FR	15,0	9,52	3,97	4,4	0,8	1,6			●
LDHT 15T3PDFR	15,0	9,52	3,97	4,4	0,8	1,6			●
LDHT 15T3PDSR	15,0	9,52	3,97	4,4	0,8	1,6	●		
LDHW 15T3PDER	15,0	9,52	3,97	4,4	0,8	1,6			●
LDHW 15T3PDSR	15,0	9,52	3,97	4,4	0,8	1,6		●	

	P	M	K	N	S	H
● Hauptanwendung Main application Applicazione principale	●	●				
○ Nebenanwendung Secondary application Applicazione secondaria			○			

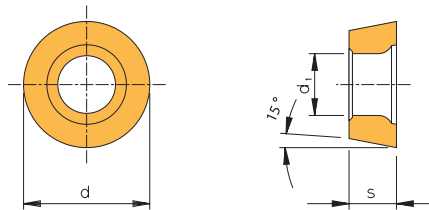

RD..



Bezeichnung Designation Articolo	l	d	s	d ₁	r	b _s
RDHT 10T3MOSN	-	10,00	3,97	3,90	-	-
RDHT 12T3MOEN	-	12,00	3,97	4,10	-	-
RDHW 1003MOSN	-	10,00	3,18	3,90	-	-
RDHW 12T3MOSN	-	12,00	3,97	4,10	-	-
RDLT 12T3MOSN	-	12,00	3,97	4,10	-	-
RDLW 1003MOSN	-	10,00	3,18	3,90	-	-
RDLW 12T3MOSN	-	12,00	3,97	4,10	-	-
RDLW 1604MOSN	-	16,00	4,76	5,00	-	-

5

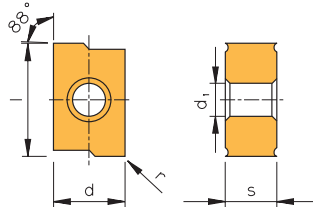

LN..



Bezeichnung Designation Articolo	Sorten / Grades / Gradi							beschichtet/coated/rivestito			unbeschichtet/ uncoated/ non rivestito
	l	d	s	d ₁	r	b ₁	AK2120	AM2130	AP2125	AK20F	
LNMX 100605EN-PNR	10,0	6,50	6,50	3,5	0,5	-	●	●	●		
LNMX 151008EN-PNR	15,0	10,00	10,00	4,5	0,8	-	●	●	●		
LNEX 100605FN-PNR	10,0	6,50	6,50	3,5	0,5	-				●	
LNEX 151008FN-PNR	15,0	10,00	10,00	4,5	0,8	-				●	

● Hauptanwendung Main application Applicazione principale	P	○		●		
	M		●	○		
○ Nebenanwendung Secondary application Applicazione secondaria	K	●		●		○
	N					●
	S				○	
	H					○

Sorten / Grades / Gradi								Bezeichnung Designation Articolo
beschichtet/coated/rivestito				unbeschichtet/uncoated/non rivestito				
AL160	AL260	AL360	AM36C	AK05F	AK10F	AP20F	AP40F	
			●					RDHT 10T3MOSN
				●				RDHT 12T3MOEN
●	●	●					●	RDHW 1003MOSN
●	●			●				RDHW 12T3MOSN
		●					●	RDLT 12T3MOSN
●		●			●	●	●	RDLW 1003MOSN
●	●	●			●	●	●	RDLW 12T3MOSN
●		●			●		●	RDLW 1604MOSN

● Hauptanwendung Main application Applicazione principale	P	●	●	●		●	●	P
	M	○	●	●		○	○	M
○ Nebenanwendung Secondary application Applicazione secondaria	K	●	○		●	●		K
	N				●	●		N
	S							S
	H							H

Wendeschneidplatten – Hartmetall

Indexable inserts – Carbide

Inserti a fissaggio meccanico – Metallo duro

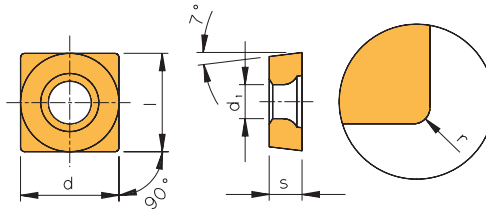

SC..



Bezeichnung Designation Articolo	l	d	s	d ₁	r	b _s
SCMT 060204EN	6,35	6,35	2,38	2,8	0,4	-
SCMT 09T304EN-AM	9,525	9,525	3,97	4,4	0,4	-
SCMT 09T308EN-AM	9,525	9,525	3,97	4,4	0,8	-
SCMT 120404EN-AM	12,70	12,70	4,76	5,5	0,4	-
SCMT 120408EN-AM	12,70	12,70	4,76	5,5	0,8	-
SCMT 09T304EN-PM1	9,525	9,525	3,97	4,4	0,4	-
SCMT 120408EN-PMS	12,70	12,70	4,76	5,5	0,8	-
SCMT 120412EN-PMS	12,70	12,70	4,76	5,5	1,2	-

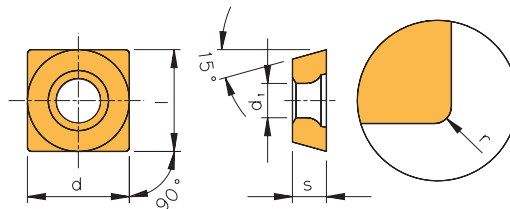

SD..



Bezeichnung Designation Articolo	l	d	s	d ₁	r	b _s
SDHT 060304EN	6,35	6,35	3,18	2,8	0,4	-
SDHT 060304FN	6,35	6,35	3,18	2,8	0,4	-
SDHT 090304SN	9,52	9,52	3,18	4,4	0,4	-
SDHT 09T3AEEN	9,52	9,52	3,97	4,4	-	-
SDHT 1204AESN	12,70	12,70	4,76	5,5	-	1,7
SDHW 090304EN	9,52	9,52	3,18	4,4	0,4	-
SDHW 09T3AEEN	9,52	9,52	3,97	4,4	-	-
SDHW 09T3AESN	9,52	9,52	3,97	4,4	-	-
SDHW 1204AEEN	12,70	12,70	4,76	5,5	-	1,7
SDMT 1205PDER	12,70	12,70	5,56	4,4	0,8	-

5

Sorten / Grades / Gradi										
beschichtet/coated/rivestito										
	AM2035	AM2130	AM26C	AM5120	AP2025	AP2035	AP2310	AP2320	AP2335	Bezeichnung Designation Articolo
			●							SCMT 060204EN
		●		●			●	●	●	SCMT 09T304EN-AM
	●	●		●		●	●	●	●	SCMT 09T308EN-AM
		●		●	●	●				SCMT 120404EN-AM
		●		●			●	●	●	SCMT 120408EN-AM
		●						●		SCMT 09T304EN-PM1
						●				SCMT 120408EN-PMS
						●				SCMT 120412EN-PMS
P	○		●	○	●	●	●	●	●	P ● Hauptanwendung Main application Applicazione principale
M	●	●	○	●	○	○				M ● Hauptanwendung Main application Applicazione principale
K				○	●					K ○ Nebenanwendung Secondary application Applicazione secondaria
N				○						N ○ Nebenanwendung Secondary application Applicazione secondaria
S	●			●						S ● Hauptanwendung Main application Applicazione principale
H				○						H ○ Nebenanwendung Secondary application Applicazione secondaria

Sorten / Grades / Gradi						
beschichtet/coated/rivestito			unbeschichtet/uncoated/non rivestito			Bezeichnung Designation Articolo
AL136	AM36C	AR26C	AK10F	AP20F	AP40F	
					●	SDHT 060304EN
			●			SDHT 060304FN
						SDHT 090304SN
	●	●	●			SDHT 09T3AEEN
	●	●			●	SDHT 1204AESN
			●			SDHW 090304EN
			●			SDHW 09T3AEEN
		●				SDHW 09T3AESN
			●			SDHW 1204AEEN
		●			●	SDMT 1205PDER
P	●	●	●		●	P ● Hauptanwendung Main application Applicazione principale
M	●	●			○	M ● Hauptanwendung Main application Applicazione principale
K			○	●		K ○ Nebenanwendung Secondary application Applicazione secondaria
N				●		N ○ Nebenanwendung Secondary application Applicazione secondaria
S						S ● Hauptanwendung Main application Applicazione principale
H						H ○ Nebenanwendung Secondary application Applicazione secondaria

Wendeschneidplatten – Hartmetall

Indexable inserts – Carbide

Inserti a fissaggio meccanico – Metallo duro

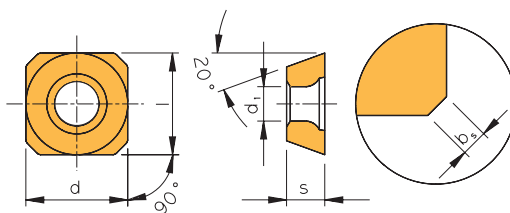

SE..

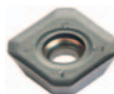

Bezeichnung
Designation
Articolo

	l	d	s	d ₁	r	b _s
SEHT 1204AFSN	12,7	12,7	4,76	5,5	-	1,7
SEHW 1204AFSN	12,7	12,7	4,76	5,5	-	1,7
SEKN 1203AFSN	12,7	12,7	3,18	-	-	1,7
SEKR 1203AFFN	12,7	12,7	3,18	-	-	1,7
SEKR 1203AFSN	12,7	12,7	3,18	-	-	1,7
SEMT 13T3AGSN	13,4	13,4	3,97	4,1	-	1,5

Sorten / Grades / Gradi						
beschichtet/coated/rivestito				unbeschichtet/ uncoated/non rivestito		
	AM36C	AM5635	AP5635	AR26C	AK10F	Bezeichnung Designation Articolo
	●			●		SEHT 1204AFSN
	●					SEHW 1204AFSN
	●			●		SEKN 1203AFSN
	●			●	●	SEKR 1203AFFN SEKR 1203AFSN
		●	●			SEMT 13T3AGSN
P	●	○	●	●		P ● Hauptanwendung Main application Applicazione principale
M	●	●	○			M ●
K				○	●	K ○ Nebenanwendung Secondary application Applicazione secondaria
N					●	N ●
S						S
H						H

Wendeschneidplatten – Hartmetall

Indexable inserts – Carbide

Inserti a fissaggio meccanico – Metallo duro

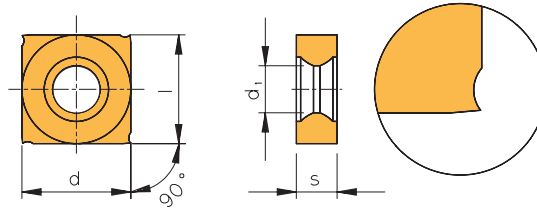

SN..



Bezeichnung Designation Articolo	l	d	s	d ₁	r	b _s	Sorten / Grades / Gradi			unbeschichtet/ uncoated/ non rivestito
							beschichtet/coated/rivestito			
							AM26C	AM36C	AR26C	AK10F
SNHX 1102T	11,0	11,0	2,3	4,4	-	-	●			
SNHX 1103T	11,0	11,0	2,7	4,4	-	-	●			
SNHX 1203T	12,7	12,7	3,2	5,0	-	-		●		●
SNHX 1205T	12,7	12,7	5,4	5,0	-	-		●	●	
							● Hauptanwendung Main application Applicazione principale			
							○ Nebenanwendung Secondary application Applicazione secondaria			
							P	●	●	●
							M	○	●	
							K		○	●
							N			●
							S			
							H			

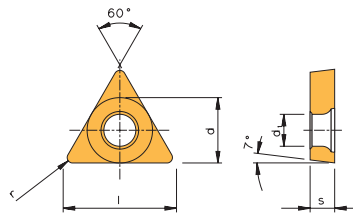

TC..

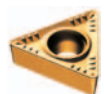

Bezeichnung Designation Articolo	l	d	s	d ₁	r
TCMT 06T104EN-AM	6,35	3,970	1,98	2,34	0,4
TCMT 110204EN-AM	11,00	6,350	2,38	2,8	0,4
TCMT 110208EN-AM	11,00	6,350	2,38	2,8	0,8
TCMT 16T304EN-AM	16,50	9,525	3,97	4,4	0,4
TCMT 16T308EN-AM	16,50	9,525	3,97	4,4	0,8
TCMT 110202EN-PM1	11,00	6,350	2,38	2,8	0,2
TCMT 110204EN-PM1	11,00	6,350	2,38	2,8	0,4
TCMT 16T304EN-PM1	16,50	9,525	3,97	4,4	0,4
TCMT 16T308EN-PM1	16,50	9,525	3,97	4,4	0,8
TCGX 163504EN	16,50	9,525	3,97	4,4	0,4
TCMX 16T3ZR*	16,50	9,525	3,97	4,4	-

* Breitschichtplatte
* Wiper insert
* Inserto raschiante

5

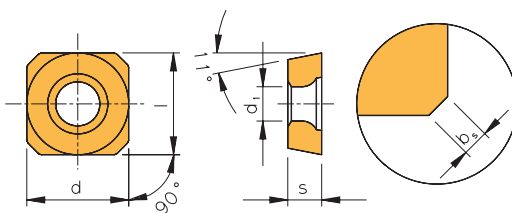

SP..



Bezeichnung Designation Articolo	l	d	s	d ₁	r	b _s	Sorten / Grades / Gradi	
							AM26C	AM36C
SPHT 1204AESN	12,7	12,7	4,76	5,5	-	1,7	●	●
SPKN 1203EDSR	12,7	12,7	3,18	-	-	1,5	●	●
SPMT 060304EN	6,35	6,35	3,18	2,8	0,4	-	●	●
SPMT 09T308EN	9,52	9,52	3,97	4,5	0,8	-	●	●
SPMT 120408SN	12,7	12,7	4,76	5,5	0,8	-	●	●

- **Hauptanwendung**
Main application
Applicazione principale
- **Nebenanwendung**
Secondary application
Applicazione secondaria

P	●	●
M	○	●
K		
N		
S		
H		

Sorten / Grades / Gradi
beschichtet/coated/rivestito

AM2035	AM2130	AM350	AM5120	AP1530	AP2035	AP2120	AP2310	AP2320	AP2335	Bezeichnung Designation Articolo
		●								TCMT 06T104EN-AM
●	●		●		●		●	●	●	TCMT 110204EN-AM
	●		●				●	●	●	TCMT 110208EN-AM
	●		●				●	●	●	TCMT 16T304EN-AM
	●		●				●	●	●	TCMT 16T308EN-AM
	●					●				TCMT 110202EN-PM1
	●					●				TCMT 110204EN-PM1
	●							●		TCMT 16T304EN-PM1
	●							●		TCMT 16T308EN-PM1
				●						TCGX 163504EN
				●						TCMX 16T3ZR*

P	○	○	○	●	●	●	●	●	●	P
M	●	●	●	○	○					M
K				●						K
N				○						N
S	●		●	○						S
H			○							H

- **Hauptanwendung**
Main application
Applicazione principale
- **Nebenanwendung**
Secondary application
Applicazione secondaria

Wendeschneidplatten – Hartmetall

Indexable inserts – Carbide

Inserti a fissaggio meccanico – Metallo duro

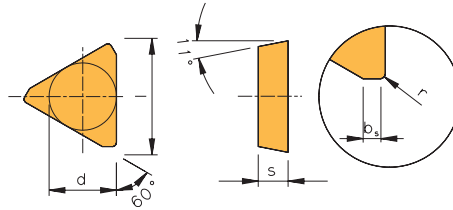

TP..



Bezeichnung Designation Articolo	l	d	s	d ₁	r	b _s	Sorten / Grades / Gradi		
							beschichtet/coated/rivestito AM36C	AR26C	unbeschichtet/ uncoated/ non rivestito AK10F
TPKN 1603PDER	16,5	9,52	3,18	-	-	1,3	●		●
TPKN 1603PDSR	16,5	9,52	3,18	-	-	1,3	●		
TPKN 2204PDSR	22,0	12,70	4,76	-	-	1,4	●	●	

- **Hauptanwendung**
Main application
Applicazione principale
- **Nebenanwendung**
Secondary application
Applicazione secondaria

P	●	●	
M	●		
K		○	●
N			●
S			
H			

Beschichtet / Coated / Rivestito**AM15C**

CVD-Mehrlagenbeschichtung
Sorte in Verbindung mit der ALU-Spanformgeometrie für die Bearbeitung von legierten und rostfreien Stählen sowie Stahlguß im Schlichtbereich mit hohen Schnittgeschwindigkeiten unter guten Bearbeitungsbedingungen. Bitte beachten: Auf Grund der verrundeten Schneidkante nicht für die Bearbeitung von NE-Metallen geeignet.

CVD-multilayer coating
Grade in combination with ALU-geometry for finishing alloyed and stainless steel as well as cast steel at high cutting speeds under stable machining conditions.
Attention: Because of a small edge honing, this grade is not suitable for machining non-ferrous products.

Rivestimento CVD-multistrato
 Grado che abbinato alla geometria rompitrucolo ALU e con la preparazione apposita del tagliente è specifico per la finitura di acciai legati e inossidabili nonché fusioni con elevate velocità di taglio in buone condizioni di lavoro.
 Attenzione: a causa della speciale preparazione del tagliente non è idoneo per la lavorazione di metalli non ferrosi.

AM5015

PVD-Mehrlagenbeschichtung
Verschleißfeste Sorte mit guter Schneidkanten-sicherheit zur Bearbeitung von Stählen, Stahl-guss, rostfreien Stählen und hochwarmfesten Werkstoffen (auch Superlegierungen und Hochtemperaturlegierungen).

PVD-multilayer coating
Wear resistant grade for machining steel, cast steel, stainless steel and high temperature alloys (super alloys).

Rivestimento PVD-multistrato
 Qualità resistente all'usura con un buon filo tagliente per la lavorazione di acciaio, acciaio da fusione, acciaio inossidabile e materiali refrattari come superleghe e leghe ad alta temperatura.

AM5020

PVD-Mehrlagenbeschichtung
Für die Schlichtbearbeitung von rostfreien Stählen und warmfesten Stählen. Die Sorte AM5020 ist optimal eingesetzt beim Feinbearbeiten von schwierigen Werkstoffen mit mittleren Schnittgeschwindigkeiten. Sie weist eine hohe Zähigkeit und eine gute Verschleißfestigkeit auf.

PVD-multilayer coating
This grade is ideal for finishing of stainless steel and high temperature steel. Apply grade AM5020 when finishing difficult to machine materials at medium cutting speeds. The grade has high toughness combined with good wear resistance.

Rivestimento PVD-multistrato
 Qualità ideale per la finitura di acciaio inossidabile e leghe refrattarie ed esotiche. L'applicazione della qualità AM5020 è suggerita nella lavorazione di materiali di difficile lavorabilità a medie velocità di taglio.

AM5025

PVD-Mehrlagenbeschichtung
Optimale Sorte für die Bearbeitung von rost-freien Stählen, warmfesten Stählen und Titan(legierungen) bei der Schlicht- bis mittleren Bearbeitung. Die AM5025 weist eine sehr gute Zähigkeit und eine gute Verschleißfestigkeit auf. Sie ist auch für wechselnde Schnitt-tiefen und unterbrochene Schnitte geeignet.

PVD-multilayer coating
Ideal grade for finish to medium machining of stainless steel, temperature resistant steel and titanium (alloys). AM5025 has very good toughness and good wear resistance and can be used both at varied cutting depth and interrupted cutting.

Rivestimento PVD-multistrato
 Qualità ideale per la finitura e semi-finitura di acciaio inossidabile, leghe refrattarie ed esotiche e leghe di titanio. AM5025 ha una ottima tenacità combinata ad una ottima resistenza all'usura e può essere utilizzato con profondità di passata variabili e con taglio interrotto.

AM5110

PVD-Mehrlagenbeschichtung
Sorte zur Feinbearbeitung von VA-Stählen, Nickel- und Titanlegierungen und exotischen Werkstoffen. Bearbeitung abrasiver und naturharter Werkstoffe wie CoCrMo oder Hartguss.

PVD-multilayer coating
Grade for finish machining of stainless steel, nickel and titanium alloys as well as exotic materials. Also for abrasive and hard materials such as CoCrMo and chilled cast iron.

Rivestimento PVD-multistrato
 Qualità sviluppata per la lavorazione di precisione di acciai inossidabili, leghe di Nichel, leghe di Titanio, e materiali esotici. Ottima per la lavorazione di materiali abrasivi e duri come leghe Co, Cr, Mo o ghise dure.

AM5120+

PVD-Mehrlagenbeschichtung
Geeignet für die mittlere und gröbere Bearbeitung von zähen, exotischen Werkstoffen wie E-Cu, Molybdän, Nickel, Reineisen. Fräsen in Inconel und VA-Stählen bei hoher Schneidkantenstabilität.

PVD-multilayer coating
Suitable for medium and roughing of tough exotic materials such as pure copper, molybdenum, nickel, pure iron, Inconel and stainless steel.

Rivestimento PVD-multistrato
 Qualità adatta alla sgrossatura media di materiali esotici come E-Co, leghe con Molibdeno, Nichel, ferro puro. Idoneo anche per la fresatura di Inconel e acciai inossidabili.

AP5210**PVD-Mehrlagenbeschichtung**

Universelle Sorte zur Feinbearbeitung von Stahl und rostfreien Stählen. Auch sehr gut geeignet für die mittlere und Feinbearbeitung von exotischen Werkstoffen, Titan und Titanlegierungen sowie Nickellegierungen. Hohe Beständigkeit bei der Bearbeitung abrasiver und naturharter Werkstoffe wie CoCrMo und Hartguss.

PVD-multilayer coating

Medium to light machining of exotic materials, titanium, titanium alloys, nickel alloys, machining of abrasive and hard materials such as CoCrMo or chilled cast iron. Finishing of steel and stainless steel.

Rivestimento PVD-multistrato

Qualità per media asportazione e finitura di materiali esotici, leghe di Titanio, leghe di Nichel. Ottima per la lavorazione di materiali abrasivi o duricome leghe Co, Cr, Mo o ghise dure. Ottima per la superfinitura di acciai e acciai inossidabili.

AL10**PVD-Mehrlagenbeschichtung**

Extrem verschleißfeste Sorte zur Bearbeitung von Stählen, Grauguss und NE-Metallen. Die Sorte zeichnet sich durch die hohe Beschichtungshärte und die äußerst hohe Verschleißfestigkeit aus. Besonders geeignet für sehr hohe Schnittgeschwindigkeiten.

PVD-multilayer coating

Extremely wear resistant grade for machining steel materials, cast iron and non ferrous products. Due to high hardness in coating, high wear-resistance can be achieved. Specially suitable for high cutting speeds.

Rivestimento PVD-multistrato

Qualità con eccellente resistenza all'usura per la lavorazione di materiali acciaioli, ghise e materiali non ferrosi. Data la notevole durezza del rivestimento viene assicurata una elevata resistenza all'usura. Molto valida per alte velocità di taglio.

AL20**PVD-Mehrlagenbeschichtung**

Verschleißfeste Sorte mit guter Schneidkantensicherheit zur Bearbeitung von Stählen, Grauguss und NE-Metallen. Die Sorte zeichnet sich durch die hohe Beschichtungshärte und die gute Verschleißfestigkeit aus.

PVD-multilayer coating

Wear resistant grade with good cutting edge stability for machining steel materials, cast iron and non ferrous products. Due to the high hardness in coating, good wearresistance can be achieved.

Rivestimento PVD multistrato

Qualità resistente all'usura con tagliente robusto anche per lavorazione di acciai, ghisa grigia e metalli non ferrosi. E' caratterizzata da elevata durezza del rivestimento e buona resistenza all'usura.

AT10**PVD-Mehrlagenbeschichtung**

Zur Bearbeitung von Aluminium und Aluminiumlegierungen, Kupfer, Bronze, NE-Metallen und hochschmelzenden Werkstoffen (z. B. Niob, Tantal, Molybdän, Wolfram) bei mittleren Spanquerschnitten und unter ungünstigen Bearbeitungsbedingungen. Höhere Schnittwerte als bei PVD1 möglich.

PVD-multilayer coating

Grade for machining aluminium and aluminiumalloy, cooper, brass, non-ferrous materials and refractory metals (e. g. Niob Tantalum, molybdenum, tungsten) at medium cutting and under favourable cutting conditions. Higher cutting speeds can be used as grade PVD1.

Rivestimento PVD multistrato

Qualità per la lavorazione di alluminio e leghe di alluminio, rame, bronzo, metalli non ferrosi e metalli refrattari (ad esempio, niobio, tantalio, molibdeno, tungsteno) in semifinitura e in condizioni di lavoro sfavorevoli.

AT20**PVD-Mehrlagenbeschichtung**

Hartmetallsorte mit höherer Zähigkeit zur Bearbeitung von Aluminium und Aluminiumlegierungen, Kupfer, Bronze, NE-Metallen und hochschmelzenden Werkstoffen (z. B. Niob, Tantal, Molybdän, Wolfram) bei mittleren Spanquerschnitten und unter ungünstigen Bearbeitungsbedingungen (unterbrochene Schnitte). Höhere Schnittwerte als bei PVD2 möglich.

PVD-multilayer coating

Grade with higher toughness for machining aluminium and aluminiumalloys, copper, brass, non-ferrous materials and refractory metals (e. g. Niob, Tantalum, molybdenum, tungsten) at medium cutting and under unfavourable cutting conditions. Higher cutting speeds can be used as grade PVD2.

Rivestimento PVD multistrato

Qualità con maggiore tenacità per la lavorazione di alluminio e leghe di alluminio, rame, bronzo, metalli non ferrosi e materiali refrattari (es niobio, tantalio, molibdeno, tungsteno) in semifinitura e in condizioni di lavoro sfavorevoli.

PVD1**PVD-Mehrlagenbeschichtung**

Feinkorn-Hartmetallsorte mit hoher Verschleißfestigkeit und gutem Widerstand gegen plastische Verformung für die leichte bis mittlere Zerspanung. Speziell zur Zerspanung von Nicht-eisenmetallen, wie z. B. Al und Al-Legierungen, Kupfer, Bronze und hochschmelzenden Werkstoffen (z. B. Niob, Tantal, Molybdän, Wolfram).

PVD-multilayer coating

Submicron carbide grade with high wear-resistance and resistance against crater wear. Light to medium cutting. Excellent for machining non-ferrous products, e. g. Al and Al-alloys, copper, brass and refractory metals (e. g. niob, tantalum, molybdenum, tungsten).

Rivestimento PVD multistrato

Grado con grana fine ed elevata resistenza all'usura oltre ad una buona resistenza alla deformazione plastica in finitura e semifinitura. Specifico per la lavorazione di metalli non ferrosi, come Al e Al-leghe Rame, bronzo e materiali refrattari (per esempio niobio, tantalio, molibdeno, tungsteno).

PVD2

PVD-Mehrlagenbeschichtung
Verschleißfeste Sorte mit guter Schneidkantensicherheit zur Bearbeitung von Nichteisenmetallen, wie z. B. Al und Al-Legierungen, Kupfer, Bronze und hochschmelzenden Werkstoffen (z. B. Niob, Tantal, Molybdän, Wolfram) unter ungünstigen Bearbeitungsbedingungen. Auch geeignet für die Zerspanung von Stahl und rostfreiem Stahl im unteren Schlichtbereich bei guten Bearbeitungsbedingungen.

PVD-multilayer coating
Wear resistant grade with good cutting edge stability for machining non-ferrous materials, e. g. Al and Al-alloys, copper brass and refractory metals (e. g. niob, tantalum, molybdenum, tungsten) under unfavourable machining conditions. Also suitable for finishing steel and stainless steel under favourable machining conditions.

Rivestimento PVD multistrato
Qualità resistente all'usura con buona tenacità per la lavorazione di metalli non ferrosi, come ad esempio Alluminio Al leghe, rame, bronzo e materiali refrattari (es niobio, tantalio, molibdeno, tungsteno) in condizioni di lavoro sfavorevoli. Adatto anche per la lavorazione di acciaio e acciaio inossidabile in spianatura con buone condizioni di lavoro.

AD2

PVD-Mehrlagenbeschichtung, Substrat + Diamantbeschichtung.
Beschichtete Hartmetallsorte zur Bearbeitung von Al und Al-Legierungen, Kupfer, Bronze, NE-Metallen bei mittleren Spanquerschnitten und unter optimalen Bearbeitungsbedingungen. Jedoch wesentlich höhere Standzeiten als bei AK20 möglich.

PVD-multilayer coating, substrate + diamond coating.
Coated grade for machining Al and Al-alloys, copper brass and non-ferrous metals at medium cutting datas and under optimum machining conditions. Excellent tool-life compared with grade AK20 can be achieved.

Rivestimento PVD multistrato, substrato + rivestimento diamantato.
Qualità rivestita per la lavorazione di alluminio e leghe di alluminio, rame, bronzo, metalli non ferrosi a media asportazione e in condizioni di lavorazione ottimali. Idonea anche alla lavorazione di plastiche, plastiche rinforzate, grafite e fibre di carbonio.

Unbeschichtet / Uncoated / Non rivestito**AK10 (F)**

Feinkorn-Hartmetall zur Bearbeitung von Al und Al-Legierungen, Kupfer, Bronze, NE-Metalle und hochschmelzenden Werkstoffen (z. B. Niob, Tantal, Titan, Molybdän, Wolfram) bei mittleren Spanquerschnitten unter günstigen Bearbeitungsbedingungen.

Submicron carbide grade for machining Al and Al-alloys, copper, brass, non-ferrous and refractory metals (e. g. niob, tantalum, titanium, molybdenum, tungsten) with medium chip cross sections under favourable machining conditions.

Metallo duro micrograna per la lavorazione di alluminio e leghe di alluminio, rame, bronzo, metalli non ferrosi e materiali refrattari (per esempio niobio, tantalio, titanio, molibdeno, tungsteno) per medie asportazioni ed in condizioni di lavoro favorevoli.

AK20 (F)

Hartmetallsorte mit höherer Zähigkeit zur Bearbeitung von Al und Al-Legierungen, Kupfer, Bronze, NE-Metalle und hochschmelzenden Werkstoffen (z. B. Niob, Tantal, Molybdän, Wolfram) bei mittleren Spanquerschnitten unter ungünstigen Bearbeitungsbedingungen, wie unterbrochene Schnitte.

A grade with great resilience for machining Al- and Al-alloys, copper, brass, non-ferrous and refractory metals (e. g. niob, tantalum, molybdenum, tungsten) with medium chip cross sections under unfavourable machining conditions and interrupted cuts.

Grado di metallo duro con maggiore tenacità rispetto a AK10 per la lavorazione di alluminio e leghe di alluminio, rame, bronzo, metalli non ferrosi e materiali di elevato punto di fusione (per esempio, niobio, tantalio, molibdeno, tungsteno) con refrigerante anche per condizioni di lavoro sfavorevoli.

ISO	Hochpositiv beschichtet High positive coated Ultra positivi rivestito	Hochpositiv unbeschichtet High positive uncoated Ultra positivi non rivestito	Schneidstoff Cutting material Materiale da taglio	Anwendung Application Parametri
P Stahl, Stahlguss, langspanender Temperguss <i>Steel, cast steel, malleable iron</i> Acciaio, acciaio da fusione, ghisa malleabile da truciolo lungo	AL10, AL20, AM15C, AM5015, AM5020, AM5110, AP5210, AT10, AT20, PVD1, PVD2		Zähigkeit / Toughness / Tenacità Verschleißbeständigkeit / Wear resistance / Resistenza all'usura	Vorschub / Feed rate / Avanzamento Schnittgeschwindigkeit / Cutting speed / Velocità di taglio
M Rostfreier Stahl, Stahlguss, Manganstahl, Automatenstahl <i>Stainless steel, cast steel, manganese steel, free cutting steel</i> Acciaio Inossidabile, Acciaio da Fusione, Acciaio al Manganese, Acciaio Automatico	AL10, AL20, AM15C, AM5015, AM5020, AM5025, AM5110, AP5210, AT10, AT20, PVD1, PVD2		Zähigkeit / Toughness / Tenacità Verschleißbeständigkeit / Wear resistance / Resistenza all'usura	Vorschub / Feed rate / Avanzamento Schnittgeschwindigkeit / Cutting speed / Velocità di taglio
K Grauguss, Kokillenhartguss, kurzspanender Temperguss <i>Grey cast iron, chilled hard cast iron, short chipping malleable iron</i> Ghisa grigia, ghisa sferoidale, ghisa malleabile a truciolo corto	AL10, AL20, AM15C, AM5015, AM5110, AP5210, AT10, AT20	AK10, AK10F, AK20, AK20F	Zähigkeit / Toughness / Tenacità Verschleißbeständigkeit / Wear resistance / Resistenza all'usura	Vorschub / Feed rate / Avanzamento Schnittgeschwindigkeit / Cutting speed / Velocità di taglio
N Aluminium und Al-Legierungen, nichtmetallische Werkstoffe <i>Aluminum and Al-alloys, non-ferrous materials</i> Alluminio e sue leghe, materiali non ferrosi o non metallici	AD2, AM5110, AM520F, AT10, AT20, PVD1, PVD2	AK10, AK10F, AK20, AK20F	Zähigkeit / Toughness / Tenacità Verschleißbeständigkeit / Wear resistance / Resistenza all'usura	Vorschub / Feed rate / Avanzamento Schnittgeschwindigkeit / Cutting speed / Velocità di taglio
S Warmfeste Legierungen, Titanlegierungen <i>High temperature resistant alloys, titanium alloys</i> Leghe refrattarie, leghe esotiche, leghe di titanio	AL10, AL20, AM5015, AM5110, AM520F, AP5210		Zähigkeit / Toughness / Tenacità Verschleißbeständigkeit / Wear resistance / Resistenza all'usura	Vorschub / Feed rate / Avanzamento Schnittgeschwindigkeit / Cutting speed / Velocità di taglio
H Gehärteter Stahl, Hartguss <i>Hardened steel, hard cast iron</i> Acciaio temprato, ghisa temprata	AL10, AL20, AM5015, AM5110		Zähigkeit / Toughness / Tenacità Verschleißbeständigkeit / Wear resistance / Resistenza all'usura	Vorschub / Feed rate / Avanzamento Schnittgeschwindigkeit / Cutting speed / Velocità di taglio

Hauptanwendungsbereich / Main application area / Applicazione principale

 Sorte / Grade / Qualità
 Empfohlener Anwendungsbereich / Recommended application area / Applicazione consigliata

Nebenanwendungsbereich / Secondary application area / Applicazione secondaria

 Sorte / Grade / Qualità
 Empfohlener Anwendungsbereich / Recommended application area / Applicazione consigliata

Wendeschneidplatten – Hochpositiv

Indexable inserts – High positive

Inserti a fissaggio meccanico – Ultra positivi

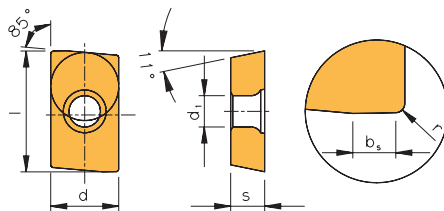

AP..

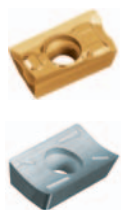

Bezeichnung Designation Articolo	Sorten / Grades / Gradi									
	beschichtet/coated/rivestito							unbeschichtet/ uncoated/ non rivestito		
	l	d	s	d ₁	r	b _s	AT20	PVD2	AD2	AK20F
APHT 1003PDFR-ALU	10,5	6,70	3,18	2,85	0,6	1,5	●		●	●
APHT 1604PDFR-ALU	16,3	9,52	4,76	4,4	0,8	2,5	●	●	●	●
APHX 100304FR-ALU	10,5	6,70	3,18	2,85	0,4	1,5				●
APHX 1604PDFR-ALU	16,3	9,52	4,76	4,4	0,8	2,5				●
● Hauptanwendung Main application Applicazione principale							P	○	○	
							M	○	○	
○ Nebenanwendung Secondary application Applicazione secondaria							K	○		○
							N	●	●	●
							S			
							H			

Wendeschneidplatten – Hochpositiv

Indexable inserts – High positive

Inserti a fissaggio meccanico – Ultra positivi

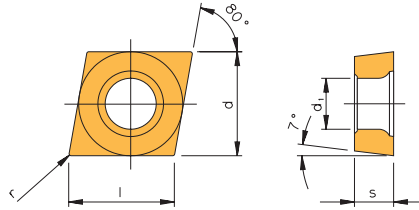

CC..

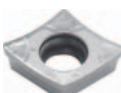
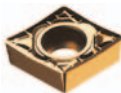
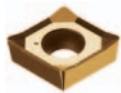

Bezeichnung
Designation
Articolo

	l	d	s	d ₁	r
CCGT 0602005FN-ALU	6,45	6,350	2,38	2,8	0,05
CCGT 060201EN-ALU	6,45	6,350	2,38	2,8	0,1
CCGT 060201FN-ALU	6,45	6,350	2,38	2,8	0,1
CCGT 060202EN-ALU	6,45	6,350	2,38	2,8	0,2
CCGT 060202FN-ALU	6,45	6,350	2,38	2,8	0,2
CCGT 060204EN-ALU	6,45	6,350	2,38	2,8	0,4
CCGT 060204FN-ALU	6,45	6,350	2,38	2,8	0,4
CCGT 09T301EN-ALU	9,67	9,525	3,97	4,4	0,1
CCGT 09T301FN-ALU	9,67	9,525	3,97	4,4	0,1
CCGT 09T302EN-ALU	9,67	9,525	3,97	4,4	0,2
CCGT 09T302FN-ALU	9,67	9,525	3,97	4,4	0,2
CCGT 09T304EN-ALU	9,67	9,525	3,97	4,4	0,4
CCGT 09T304FN-ALU	9,67	9,525	3,97	4,4	0,4
CCGT 09T308EN-ALU	9,67	9,525	3,97	4,4	0,8
CCGT 09T304FN-ALU	9,67	9,525	3,97	4,4	0,8
CCGT 120401EN-ALU	12,90	12,700	4,76	5,5	0,1
CCGT 120401FN-ALU	12,90	12,700	4,76	5,5	0,1
CCGT 120402EN-ALU	12,90	12,700	4,76	5,5	0,2
CCGT 120402FN-ALU	12,90	12,700	4,76	5,5	0,2
CCGT 120404EN-ALU	12,90	12,700	4,76	5,5	0,4
CCGT 120404FN-ALU	12,90	12,700	4,76	5,5	0,4
CCGT 120408EN-ALU	12,90	12,700	4,76	5,5	0,8
CCGT 120408FN-ALU	12,90	12,700	4,76	5,5	0,8
CCGT 060204FN-ACB	6,45	6,350	2,38	2,8	0,4
CCGT 09T304EN-ACB	9,67	9,525	3,97	4,4	0,4
CCGT 09T304FN-ACB	9,67	9,525	3,97	4,4	0,4
CCGT 09T308EN-ACB	9,67	9,525	3,97	4,4	0,8
CCGT 09T308FN-ACB	9,67	9,525	3,97	4,4	0,8
CCGT 120404EN-ACB	12,90	12,700	4,76	5,5	0,4
CCGT 120404FN-ACB	12,90	12,700	4,76	5,5	0,4
CCGT 120408EN-ACB	12,90	12,700	4,76	5,5	0,8
CCGT 120408FN-ACB	12,90	12,700	4,76	5,5	0,8
CCGT 0602005FN-ASF	6,45	6,350	2,38	2,8	0,05
CCGT 060201EN-ASF	6,45	6,350	2,38	2,8	0,1
CCGT 060201FN-ASF	6,45	6,350	2,38	2,8	0,1
CCGT 060202EN-ASF	6,45	6,350	2,38	2,8	0,2
CCGT 060202FN-ASF	6,45	6,350	2,38	2,8	0,2
CCGT 060204EN-ASF	6,45	6,350	2,38	2,8	0,4
CCGT 060204FN-ASF	6,45	6,350	2,38	2,8	0,4
CCGT 09T3005FN-ASF	9,67	9,525	3,97	4,4	0,05
CCGT 09T301FN-ASF	9,67	9,525	3,97	4,4	0,1
CCGT 09T302EN-ASF	9,67	9,525	3,97	4,4	0,2
CCGT 09T302FN-ASF	9,67	9,525	3,97	4,4	0,2
CCGT 09T304EN-ASF	9,67	9,525	3,97	4,4	0,4
CCGT 09T304FN-ASF	9,67	9,525	3,97	4,4	0,4
CCGT 09T308FN-ASF	9,67	9,525	3,97	4,4	0,8
CCXT 060202EN-AEC	6,45	6,350	2,38	2,8	0,2
CCXT 060204EN-AEC	6,45	6,350	2,38	2,8	0,4
CCXT 09T302EN-AEC	9,67	9,525	3,97	4,4	0,2
CCXT 09T304EN-AEC	9,67	9,525	3,97	4,4	0,4
CCXT 09T308EN-AEC	9,67	9,525	3,97	4,4	0,8
CCXT 120404EN-AEC	12,90	12,700	4,76	5,5	0,4
CCXT 120408EN-AEC	12,90	12,700	4,76	5,5	0,8

5



Sorten / Grades / Gradi

beschichtet/coated/rivestito														unbeschichtet/ uncoated/ non rivestito		Bezeichnung Designation Articolo	
AM15C	AM5015	AM5020	AM5025	AM5110	AM5120+	AP5210	AL10	AL20	AT10	AT20	PVD1	PVD2	AD2	AK10	AK20		
•							•	•	•	•	•	•	•	•	•	•	CCGT 0602005FN-ALU
•							•	•	•	•	•	•	•	•	•	•	CCGT 060201EN-ALU
•							•	•	•	•	•	•	•	•	•	•	CCGT 060201FN-ALU
•							•	•	•	•	•	•	•	•	•	•	CCGT 060202EN-ALU
•							•	•	•	•	•	•	•	•	•	•	CCGT 060202FN-ALU
•							•	•	•	•	•	•	•	•	•	•	CCGT 060204EN-ALU
•							•	•	•	•	•	•	•	•	•	•	CCGT 060204FN-ALU
•							•	•	•	•	•	•	•	•	•	•	CCGT 09T301EN-ALU
•							•	•	•	•	•	•	•	•	•	•	CCGT 09T301FN-ALU
•							•	•	•	•	•	•	•	•	•	•	CCGT 09T302EN-ALU
•							•	•	•	•	•	•	•	•	•	•	CCGT 09T302FN-ALU
•							•	•	•	•	•	•	•	•	•	•	CCGT 09T304EN-ALU
•							•	•	•	•	•	•	•	•	•	•	CCGT 09T304FN-ALU
•							•	•	•	•	•	•	•	•	•	•	CCGT 09T308EN-ALU
•							•	•	•	•	•	•	•	•	•	•	CCGT 09T308FN-ALU
•							•	•	•	•	•	•	•	•	•	•	CCGT 120401EN-ALU
•							•	•	•	•	•	•	•	•	•	•	CCGT 120401FN-ALU
•							•	•	•	•	•	•	•	•	•	•	CCGT 120402EN-ALU
•							•	•	•	•	•	•	•	•	•	•	CCGT 120402FN-ALU
•							•	•	•	•	•	•	•	•	•	•	CCGT 120404EN-ALU
•							•	•	•	•	•	•	•	•	•	•	CCGT 120404FN-ALU
•							•	•	•	•	•	•	•	•	•	•	CCGT 120408EN-ALU
•							•	•	•	•	•	•	•	•	•	•	CCGT 120408FN-ALU
							•	•	•	•	•	•	•	•	•	•	CCGT 060204FN-ACB
							•	•	•	•	•	•	•	•	•	•	CCGT 09T304EN-ACB
							•	•	•	•	•	•	•	•	•	•	CCGT 09T304FN-ACB
							•	•	•	•	•	•	•	•	•	•	CCGT 09T308EN-ACB
							•	•	•	•	•	•	•	•	•	•	CCGT 09T308FN-ACB
							•	•	•	•	•	•	•	•	•	•	CCGT 120404EN-ACB
							•	•	•	•	•	•	•	•	•	•	CCGT 120404FN-ACB
							•	•	•	•	•	•	•	•	•	•	CCGT 120408EN-ACB
							•	•	•	•	•	•	•	•	•	•	CCGT 120408FN-ACB
							•	•	•	•	•	•	•	•	•	•	CCGT 0602005FN-ASF
							•	•	•	•	•	•	•	•	•	•	CCGT 060201EN-ASF
							•	•	•	•	•	•	•	•	•	•	CCGT 060201FN-ASF
							•	•	•	•	•	•	•	•	•	•	CCGT 060202EN-ASF
							•	•	•	•	•	•	•	•	•	•	CCGT 060202FN-ASF
							•	•	•	•	•	•	•	•	•	•	CCGT 060204EN-ASF
							•	•	•	•	•	•	•	•	•	•	CCGT 060204FN-ASF
							•	•	•	•	•	•	•	•	•	•	CCGT 09T3005FN-ASF
							•	•	•	•	•	•	•	•	•	•	CCGT 09T301FN-ASF
							•	•	•	•	•	•	•	•	•	•	CCGT 09T302EN-ASF
							•	•	•	•	•	•	•	•	•	•	CCGT 09T302FN-ASF
							•	•	•	•	•	•	•	•	•	•	CCGT 09T304EN-ASF
							•	•	•	•	•	•	•	•	•	•	CCGT 09T304FN-ASF
							•	•	•	•	•	•	•	•	•	•	CCGT 09T308FN-ASF
																	CCXT 060202EN-AEC
																	CCXT 060204EN-AEC
																	CCXT 09T302EN-AEC
																	CCXT 09T304EN-AEC
																	CCXT 09T308EN-AEC
																	CCXT 120404EN-AEC
																	CCXT 120408EN-AEC

P	○	●	○	○	○	●	●	●	○	○	○	○	○				P ● Hauptanwendung Main application Applicazione principale
M	●	●	●	●	○	○	●	●	○	○	○	○	○				M ●
K	●	○		○		●	○	○	○	○				○	○		K ○ Nebenanwendung Secondary application Applicazione secondaria
N				○	●				●	●	●	●	●	●	●		N ●
S		●		●	●	●	○	○									S ●
H	○			○			○	○									H ○



Wendeschneidplatten – Hochpositiv

Indexable inserts – High positive

Inserti a fissaggio meccanico – Ultra positivi

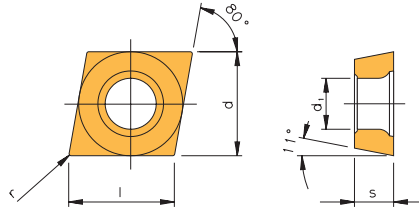

CP..



Bezeichnung
Designation
Articolo

	l	d	s	d ₁	r
CPGT 05T1005FN-ALU	5,60	5,560	1,98	2,5	0,05
CPGT 05T101FN-ALU	5,60	5,560	1,98	2,5	0,1
CPGT 05T102EN-ALU	5,60	5,560	1,98	2,5	0,2
CPGT 05T102FN-ALU	5,60	5,560	1,98	2,5	0,2
CPGT 05T104EN-ALU	5,60	5,560	1,98	2,5	0,4
CPGT 05T104FN-ALU	5,60	5,560	1,98	2,5	0,4
CPGT 05T1005FN-ASF	5,60	5,560	1,98	2,5	0,05
CPGT 05T101FN-ASF	5,60	5,560	1,98	2,5	0,1
CPGT 05T102EN-ASF	5,60	5,560	1,98	2,5	0,2
CPGT 05T102FN-ASF	5,60	5,560	1,98	2,5	0,2
CPGT 05T104EN-ASF	5,60	5,560	1,98	2,5	0,4
CPGT 05T104FN-ASF	5,60	5,560	1,98	2,5	0,4

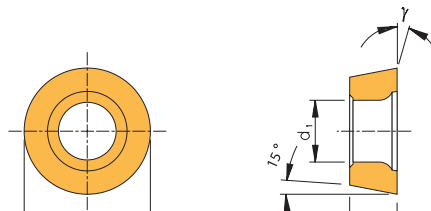

RD..



Bezeichnung Designation Articolo	l	d	s	d ₁	r	b _s	Sorten / Grades / Gradi		
							beschichtet/coated/rivestito		unbeschichtet/ uncoated/ non rivestito
							AL20	AT20	AK20F
RDHT 0501MOFN-ALU	-	5,00	1,40	2,20	-	-	●	●	●
RDHT 0702MOFN-ALU	-	7,00	2,38	2,85	-	-	●	●	●
RDHT 07T1MOFN-ALU	-	7,00	1,98	2,85	-	-	●	●	●
RDHT 1003MOFN-ALU	-	10,00	3,18	4,10	-	-	●	●	●
RDHT 12T3MOFN-ALU	-	12,00	3,97	4,10	-	-	●	●	●
RDHT 1604MOFN-ALU	-	16,00	4,76	5,10	-	-	●	●	●

- **Hauptanwendung**
Main application
Applicazione principale
- **Nebenanwendung**
Secondary application
Applicazione secondaria

	P	M	K	N	S	H
AL20	●	○	○	○	○	○
AT20	○	○	○	●	○	○
AK20F	○	○	○	○	○	○

5

Sorten / Grades / Gradi												
beschichtet/coated/rivestito										unbeschichtet/ uncoated/non rivestito		Bezeichnung Designation Articolo
AM15C	AM5025	AL10	AL20	AT10	AT20	PVD1	PVD2	AD2	AK10	AK20		
		●	●	●	●		●	●	●	●	●	CPGT 05T1005FN-ALU
		●	●	●	●				●	●	●	CPGT 05T101FN-ALU
●												CPGT 05T102EN-ALU
		●	●	●	●	●	●	●	●	●	●	CPGT 05T102FN-ALU
●												CPGT 05T104EN-ALU
		●	●	●	●	●	●	●	●	●	●	CPGT 05T104FN-ALU
		●	●		●				●	●	●	CPGT 05T1005FN-ASF
		●	●	●	●				●	●	●	CPGT 05T101FN-ASF
	●										●	CPGT 05T102EN-ASF
	●	●	●	●	●				●	●	●	CPGT 05T102FN-ASF
	●										●	CPGT 05T104EN-ASF
		●	●	●	●				●	●	●	CPGT 05T104FN-ASF
P	○	●	●	○	○	○	○					P ● Hauptanwendung Main application Applicazione principale
M	●	●	●	○	○	○	○					M ●
K	●		○	○	○	○			○	○		K ○ Nebenanwendung Secondary application Applicazione secondaria
N				●	●	●	●	●	●	●		N ●
S		●	○	○								S ●
H		○	○									H ○

Wendeschneidplatten – Hochpositiv

Indexable inserts – High positive

Inserti a fissaggio meccanico – Ultra positivi

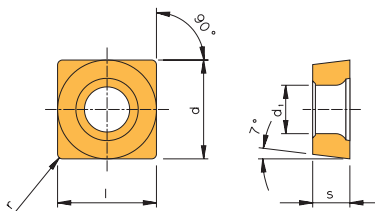

SC..



Bezeichnung
Designation
Articolo

	l	d	s	d ₁	r
SCGT 09T304EN-ALU	9,525	9,525	3,97	4,4	0,4
SCGT 09T304FN-ALU	9,525	9,525	3,97	4,4	0,4
SCGT 09T308EN-ALU	9,525	9,525	3,97	4,4	0,8
SCGT 09T308FN-ALU	9,525	9,525	3,97	4,4	0,8
SCGT 120404EN-ALU	12,700	12,700	4,76	5,5	0,4
SCGT 120404FN-ALU	12,700	12,700	4,76	5,5	0,4
SCGT 120408EN-ALU	12,700	12,700	4,76	5,5	0,8
SCGT 120408FN-ALU	12,700	12,700	4,76	5,5	0,8
SCGT 120412FN-ALU	12,700	12,700	4,76	5,5	1,2
SCGT 120416EN-ALU	12,700	12,700	4,76	5,5	1,6
SCGT 120416FN-ALU	12,700	12,700	4,76	5,5	1,6
SCGT 120404FN-ACB	12,700	12,700	4,76	5,5	0,4

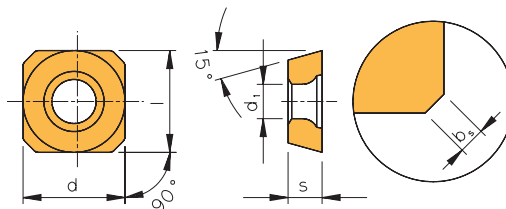

SD..



Bezeichnung
Designation
Articolo

	l	d	s	d ₁	r	b _s
SDHT 09T3AEFN-ALU	9,525	9,525	3,97	4,4	-	1,8
SDHT 1204AEFN-ALU	12,70	12,70	4,76	5,5	-	-

Sorten / Grades / Gradi										
beschichtet/coated/rivestito								unbeschichtet/ uncoated/non rivestito		Bezeichnung Designation Articolo
AM15C	AL10	AL20	AT10	AT20	PVD1	PVD2	AD2	AK10	AK20	
●								●	●	SCGT 09T304EN-ALU
●	●	●	●	●	●	●	●	●	●	SCGT 09T304FN-ALU
●	●	●	●	●	●	●	●	●	●	SCGT 09T308EN-ALU
●	●	●	●	●	●	●	●	●	●	SCGT 09T308FN-ALU
●	●	●	●	●	●	●	●	●	●	SCGT 120404EN-ALU
●	●	●	●	●	●	●	●	●	●	SCGT 120404FN-ALU
●	●	●	●	●	●	●	●	●	●	SCGT 120408EN-ALU
●	●	●	●	●	●	●	●	●	●	SCGT 120408FN-ALU
●	●	●	●	●	●	●	●	●	●	SCGT 120412FN-ALU
●	●	●	●	●	●	●	●	●	●	SCGT 120416EN-ALU
	●	●	●	●	●	●	●	●	●	SCGT 120416FN-ALU
									●	SCGT 120404FN-ACB
P	○	●	●	○	○	○	○			P ● Hauptanwendung Main application Applicazione principale
M	●	●	●	○	○	○	○			M ● Hauptanwendung Main application Applicazione principale
K	●	○	○	○	○			○	○	K ○ Nebenanwendung Secondary application Applicazione secondaria
N				●	●	●	●	●	●	N ○ Nebenanwendung Secondary application Applicazione secondaria
S		○	○							S
H		○	○							H

Sorten / Grades / Gradi										
beschichtet/coated/rivestito					unbeschichtet/uncoated/non rivestito			Bezeichnung Designation Articolo		
AT10	AT20	PVD1	PVD2	AD2	AK10F	AK20F				
●	●	●	●	●	●	●	●	●	●	SDHT 09T3AEFN-ALU
●	●	●	●	●	●	●	●	●	●	SDHT 1204AEFN-ALU
P	○	○	○	○						P ● Hauptanwendung Main application Applicazione principale
M	○	○	○	○						M ● Hauptanwendung Main application Applicazione principale
K	○	○	○		○	○				K ○ Nebenanwendung Secondary application Applicazione secondaria
N	●	●	●	●	●	●				N ○ Nebenanwendung Secondary application Applicazione secondaria
S										S
H										H

Wendeschneidplatten – Hochpositiv

Indexable inserts – High positive

Inserti a fissaggio meccanico – Ultra positivi

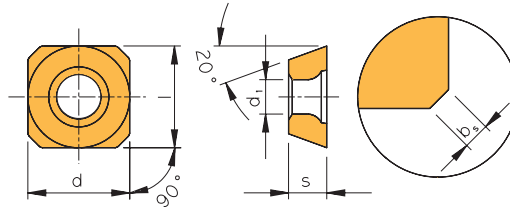

SE..



Bezeichnung Designation Articolo	l	d	s	d ₁	r	b _s	Sorten / Grades / Gradi			
							beschichtet/ coated/rivestito		unbeschichtet/ uncoated/non rivestito	
							AT10	AT20	AK10F	AK20F
SEHT 1204AFFN-ALU	12,7	12,7	4,76	5,5	-	1,8	●	●	●	●
SEHT 13T3AGFR-ALU	13,4	13,4	3,97	4,1	-	1,5			●	●

- **Hauptanwendung**
Main application
Applicazione principale
- **Nebenanwendung**
Secondary application
Applicazione secondaria

P	○	○		
M	○	○		
K	○	○	○	○
N	●	●	●	●
S				
H				

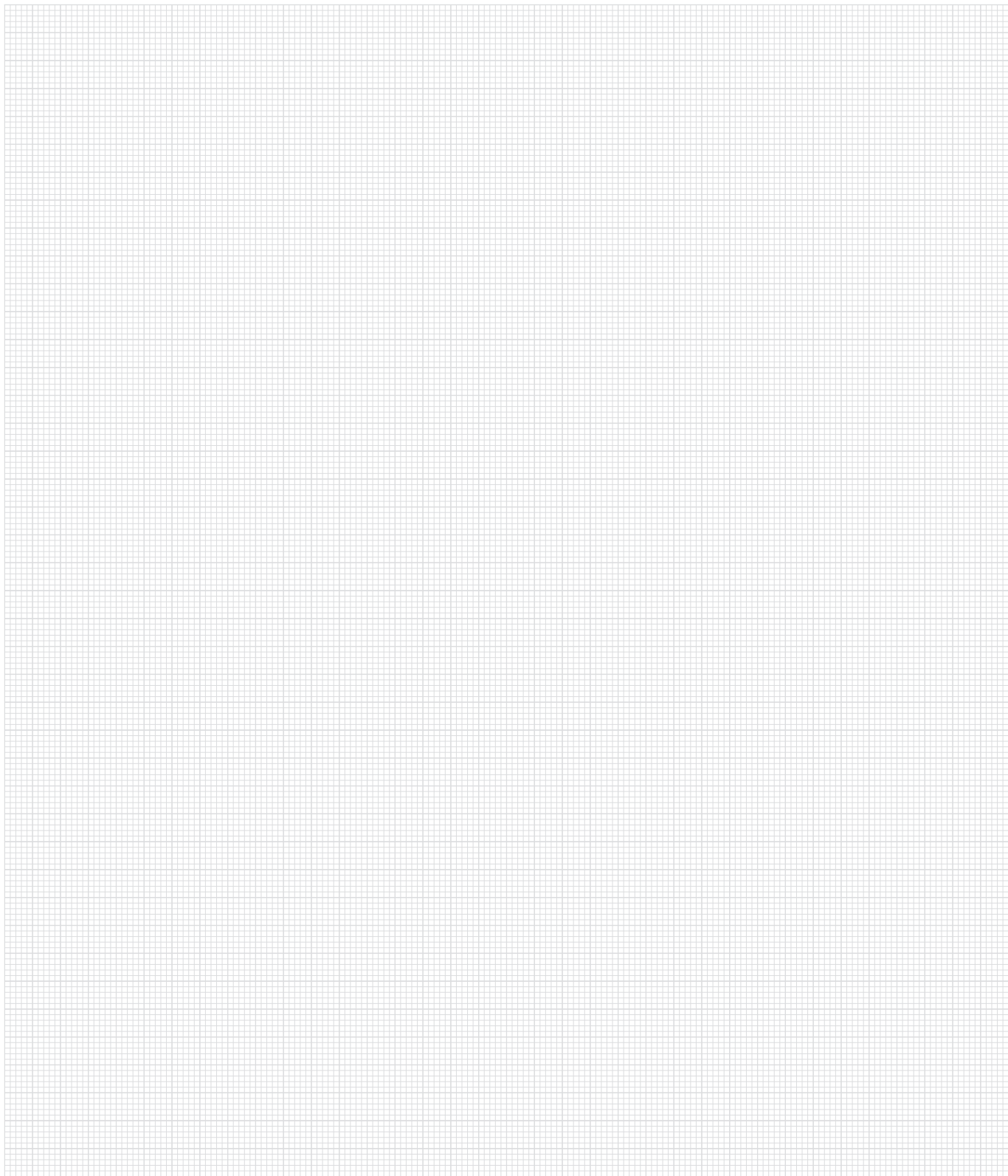

Weitere Informationen finden Sie unter
For more information see
Per maggiori informazioni visita il sito



www.arno.de

Wendeschneidplatten – Hochpositiv

Indexable inserts – High positive

Inserti a fissaggio meccanico – Ultra positivi

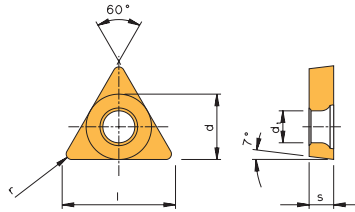

TC..



Bezeichnung
Designation
Articolo

	l	d	s	d ₁	r
TCGT 110201EN-ALU	11,00	6,350	2,38	2,8	0,1
TCGT 110201FN-ALU	11,00	6,350	2,38	2,8	0,1
TCGT 110202EN-ALU	11,00	6,350	2,38	2,8	0,2
TCGT 110202FN-ALU	11,00	6,350	2,38	2,8	0,2
TCGT 110204EN-ALU	11,00	6,350	2,38	2,8	0,4
TCGT 110204FN-ALU	11,00	6,350	2,38	2,8	0,4
TCGT 16T301FN-ALU	16,50	9,525	3,97	4,4	0,1
TCGT 16T302FN-ALU	16,50	9,525	3,97	4,4	0,2
TCGT 16T302FN-ALU	16,50	9,525	3,97	4,4	0,2
TCGT 16T304EN-ALU	16,50	9,525	3,97	4,4	0,4
TCGT 16T304FN-ALU	16,50	9,525	3,97	4,4	0,4
TCGT 16T308EN-ALU	16,50	9,525	3,97	4,4	0,8
TCGT 16T308FN-ALU	16,50	9,525	3,97	4,4	0,8
TCGT 16T312EN-ALU	16,50	9,525	3,97	4,4	1,2
TCGT 16T312FN-ALU	16,50	9,525	3,97	4,4	1,2
TCGT 16T316EN-ALU	16,50	9,525	3,97	4,4	1,6
TCGT 16T316FN-ALU	16,50	9,525	3,97	4,4	1,6
TCGT 110204FN-ACB	11,00	6,350	2,38	2,8	0,4
TCGT 16T304FN-ACB	16,50	9,525	3,97	4,4	0,4
TCGT 16T308FN-ACB	16,50	9,525	3,97	4,4	0,8
TCGT 1102005FN-ASF	11,00	6,350	2,38	2,8	0,05
TCGT 110201FN-ASF	11,00	6,350	2,38	2,8	0,1
TCGT 110202FN-ASF	11,00	6,350	2,38	2,8	0,2
TCGT 110204FN-ASF	11,00	6,350	2,38	2,8	0,4
TCGT 16T301FN-ASF	16,50	9,525	3,97	4,4	0,1
TCGT 16T302FN-ASF	16,50	9,525	3,97	4,4	0,2
TCGT 16T304FN-ASF	16,50	9,525	3,97	4,4	0,4
TCXT 16T304FN-AEC	16,50	9,525	3,97	4,4	0,4

Sorten / Grades / Gradi

	beschichtet/coated/rivestito								unbeschichtet/ uncoated/non rivestito		Bezeichnung Designation Articolo
	AM15C	AL10	AL20	AT10	AT20	PVD1	PVD2	AD2	AK10	AK20	
●	●	●	●	●	●	●		●	●	●	TCGT 110201EN-ALU
											TCGT 110201FN-ALU
●	●	●	●	●	●	●	●		●	●	TCGT 110202EN-ALU
											TCGT 110202FN-ALU
●	●	●	●	●	●	●	●	●	●	●	TCGT 110204EN-ALU
											TCGT 110204FN-ALU
●	●	●	●	●	●	●	●	●	●	●	TCGT 16T301FN-ALU
											TCGT 16T302FN-ALU
●	●	●	●	●	●	●	●	●	●	●	TCGT 16T304EN-ALU
											TCGT 16T304FN-ALU
●	●	●	●	●	●	●	●	●	●	●	TCGT 16T308EN-ALU
											TCGT 16T308FN-ALU
●	●	●	●	●	●	●	●	●	●	●	TCGT 16T312EN-ALU
											TCGT 16T312FN-ALU
●	●	●	●	●	●	●	●	●	●	●	TCGT 16T316EN-ALU
											TCGT 16T316FN-ALU
	●	●	●	●	●	●	●	●	●	●	TCGT 110204FN-ACB
	●	●	●	●	●	●	●	●	●	●	TCGT 16T304FN-ACB
	●	●	●	●	●	●	●	●	●	●	TCGT 16T308FN-ACB
	●	●	●	●	●	●	●	●	●	●	TCGT 1102005FN-ASF
	●	●	●	●	●	●	●	●	●	●	TCGT 110201FN-ASF
	●	●	●	●	●	●	●	●	●	●	TCGT 110202FN-ASF
	●	●	●	●	●	●	●	●	●	●	TCGT 110204FN-ASF
	●	●	●	●	●	●	●	●	●	●	TCGT 16T301FN-ASF
	●	●	●	●	●	●	●	●	●	●	TCGT 16T302FN-ASF
	●	●	●	●	●	●	●	●	●	●	TCGT 16T304FN-ASF
									●		TCXT 16T304FN-AEC

P	○	●	●	○	○	○	○				P	● Hauptanwendung Main application Applicazione principale
M	●	●	●	○	○	○	○				M	
K	●	○	○	○	○				○	○	K	○ Nebenanwendung Secondary application Applicazione secondaria
N				●	●	●	●	●	●	●	N	
S		○	○								S	
H		○	○								H	



Wendeschneidplatten – Hochpositiv

Indexable inserts – High positive

Inserti a fissaggio meccanico – Ultra positivi

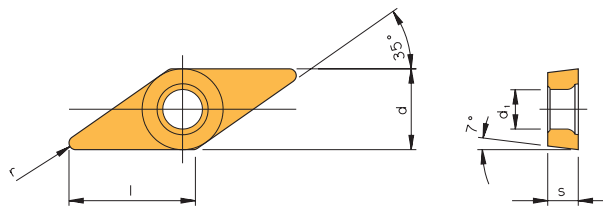

VC..



Bezeichnung Designation Articolo	l	d	s	d ₁	r	b _s	Sorten / Grades / Gradi	
							AK10F	AK20F
VCGT 220530FN-ALUM	22,10	12,70	5,56	5,5	3,0	-	●	●

- **Hauptanwendung**
Main application
Applicazione principale
- **Nebenanwendung**
Secondary application
Applicazione secondaria

P		
M		
K	○	○
N	●	●
S		
H		

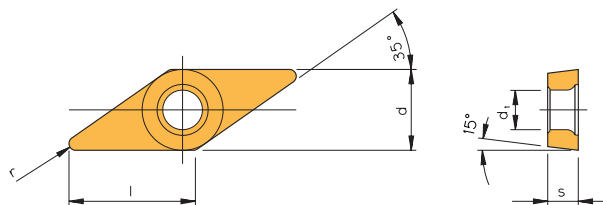

VD..



Bezeichnung Designation Articolo	l	d	s	d ₁	r	b _s	Sorten / Grades / Gradi	
							AK10F	AK20F
VDGT 11T210FN-ALU	11,10	6,35	2,78	2,9	1,0	-		●

- **Hauptanwendung**
Main application
Applicazione principale
- **Nebenanwendung**
Secondary application
Applicazione secondaria

P		
M		
K	○	
N		●
S		
H		

5

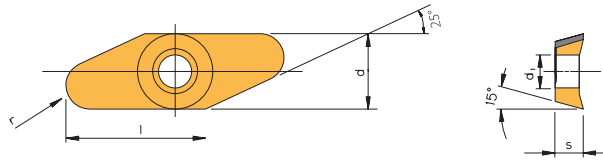

XD..



Bezeichnung Designation Articolo	l	d	s	d ₁	r	b _s	Sorten / Grades / Gradi
							unbeschichtet/ uncoated/ non rivestito
XDHT 200440FR-ALU	20,0	9,52	4,76	4,65	4,0	-	AK20F ●
XDHT 200450FR-ALU	20,0	9,52	4,76	4,65	5,0	-	●

- **Hauptanwendung**
Main application
Applicazione principale
- **Nebenanwendung**
Secondary application
Applicazione secondaria

P	
M	
K	○
N	●
S	
H	

Beschichtet / Coated / Rivestito**AP6510**

PVD-Mehrlagenbeschichtung Feinstkorn (durchschnittliche Korngröße 0,6 µm) Cermet-Sorte zur Bearbeitung von legierten und unlegierten Stählen, rostfreien Stählen und Stahlguss. Einsetzbar zum Schlichten und bei mittlerer Bearbeitung bei hohen Schnittgeschwindigkeiten. Die Sorte AP6510 weist hohe Standzeiten, stabile Schnittergebnisse, geringe Aufschweißneigung zum Werkstück, eine hohe Biegefestigkeit, geringe Abnutzung der Beschichtung sowie eine deutlich bessere Verschleißfestigkeit auf. Bei der Nassbearbeitung hat die AP6510 im Vergleich zum herkömmlichen Cermet eine deutlich höhere Stabilität.

*PVD-multilayer coating
Fine grain (average grain size 0.6 µm) Cermet.
Grade for machining alloy and none alloy steel, stainless steel and cast steel. Should be applied for finishing and medium machining at high cutting speed. AP6510 gives long tool life, constant performance, low tendency for built-up edge, high chemical stability and low oxidation wear as well as a considerable wear resistance. When cutting wet, AP6510 shows considerably higher stability over traditional Cermet.*

Rivestimento PVD-multistrato
Qualità Cermet Micrograna (dimensione media 0,6 µm) per la lavorazione di acciaio fortemente e debolmente legato, acciaio inossidabile e fusioni di acciaio. E' consigliato l'utilizzo per la finitura e la semi-finitura ad alte velocità di taglio. AP6510 assicura prolungata vita inserto, costanti prestazioni, ridotta tendenza alla formazione del tagliente di riporto, elevata stabilità chimica e bassa usura da ossidazione e da attrito. In lavorazioni con refrigerante, AP6510 dimostra una considerevole affidabilità rispetto alle tradizionali qualità Cermet.

AC90C

Beschichtete Cermet-Sorte für die Fertigbearbeitung bzw. mittlere Zerspanung. Sorte mit guter Zähigkeit und Verschleißfestigkeit. Aufgrund der PVD-Beschichtung geringe Neigung zur Bildung einer Aufbauschneide, besonders geeignet für nichtrostende Stähle.

Coated Cermet grade for light to medium machining. Good combination between toughness and wear resistance. Because of PVD-coating very little tendency for build up edge.

Qualità di Cermet rivestita per finitura e semi-finitura. AC90C è una buona combinazione tra tenacità e resistenza all'usura. Il rivestimento PVD riduce la formazione del tagliente di riporto.

Unbeschichtet / Uncoated / Non rivestito**AP6010**

Feinstkorn (durchschnittliche Korngröße 0,6 µm) Cermet-Sorte zur Bearbeitung von legierten und unlegierten Stählen, rostfreien Stählen und Stahlguss. Hohe Standzeiten beim Schlichten und bei mittlerer Bearbeitung. Zur Hochgeschwindigkeitsbearbeitung geeignet. Sie weist eine hohe Biegefestigkeit (vergleichbar mit Hartmetall), einen hohen Kolkverschleißwiderstand und eine sehr gute Verschleißfestigkeit auf. Bei hohen Schnittgeschwindigkeiten zeichnet sich die Sorte AP6010 durch eine gute Oberflächenqualität und hohe Schnittgenauigkeit aus.

*Fine grain (average grain size 0.6 µm) Cermet.
Grade for machining alloy and none alloy steel, stainless steel and cast steel. Excellent tool life when finishing and medium machining. Suitable for high speed machining. This cermet has high chemical stability (comparable with carbide). This grade has low tendency for build up edge and excellent wear resistance. AP6010 excels at high cutting speed providing very good surface finish and high accuracy.*

Qualità Cermet Micrograna (dimensione media grana 0,6 µm) per la lavorazione di acciai debolmente e fortemente legati, acciaio inossidabile, acciaio da fusione. Eccellente vita inserto in finitura e semi-finitura. Ottima per lavorazioni ad alta velocità. Questo Cermet ha una considerevole stabilità chimica rispetto al metallo duro. Qualità con ottima resistenza all'usura e ridotta tendenza alla formazione del tagliente di riporto. AP6010 eccelle nelle lavorazioni ad alta velocità assicurando buona finitura superficiale e elevata precisione.

ACE6(F)

Cermet-Sorte mit einem besseren Zähigkeitsverhalten für die Bearbeitung von Stahl, rostfreien Stahl und Gusswerkstoffe bei mittleren Spanquerschnitten und Schnittgeschwindigkeiten. Gute Widerstandsfähigkeit gegen Oxidation und Kerbverschleiß sowie geringe Neigung zur Aufbauschneidenbildung.

Cermet grade with better toughness for machining steel at medium chip cross sections and medium cutting speeds. Good resistance against oxydation, flank wear and build up edge.

Qualità Cermet con migliore tenacità per la lavorazione di acciaio a medie asportazioni e velocità di taglio. Buona resistenza all'ossidazione e usura e ridotta tendenza alla formazione del tagliente di riporto.

ISO	CERMET beschichtet CERMET coated Cermet rivestito	CERMET unbeschichtet CERMET uncoated Cermet non rivestito	Schneidstoff Cutting material Materiale da taglio	Anwendung Application Parametri
P Stahl, Stahlguss, langspanender Temperguss <i>Steel, cast steel, malleable iron</i> Acciaio, acciaio da fusione, ghisa malleabile da truciolo lungo	10	AP6510 AC90C AP6010 ACE6	Zähigkeit Toughness / Tenacità Verschleißbeständigkeit / Wear resistance / Resistenza all'usura	Vorschub Feed rate / Avanzamento Schnittgeschwindigkeit Cutting speed / Velocità di taglio
	20			
	30			
	40			
	50			
M Rostfreier Stahl, Stahlguss, Manganstahl, Automatenstahl <i>Stainless steel, cast steel, manganese steel, free cutting steel</i> Acciaio Inossidabile, Acciaio da Fusione, Acciaio al Manganese, Acciaio Automatico	10	AP6510 AC90C AP6010 ACE6	Zähigkeit Toughness / Tenacità Verschleißbeständigkeit / Wear resistance / Resistenza all'usura	Vorschub Feed rate / Avanzamento Schnittgeschwindigkeit Cutting speed / Velocità di taglio
	20			
	30			
	40			
	50			
K Grauguss, Kokillenhartguss, kurzspanender Temperguss <i>Grey cast iron, chilled hard cast iron, short chipping malleable iron</i> Ghisa grigia, ghisa sferoidale, ghisa malleabile a truciolo corto	10	ACE6	Zähigkeit Toughness / Tenacità Verschleißbeständigkeit / Wear resistance / Resistenza all'usura	Vorschub Feed rate / Avanzamento Schnittgeschwindigkeit Cutting speed / Velocità di taglio
	20			
	30			
	40			
	50			
N Aluminium und Al-Legierungen, nichtmetallische Werkstoffe <i>Aluminum and Al-alloys, non-ferrous materials</i> Alluminio e sue leghe, materiali non ferrosi o non metallici	10		Zähigkeit Toughness / Tenacità Verschleißbeständigkeit / Wear resistance / Resistenza all'usura	Vorschub Feed rate / Avanzamento Schnittgeschwindigkeit Cutting speed / Velocità di taglio
	20			
	30			
	40			
	50			
S Warmfeste Legierungen, Titanlegierungen <i>High temperature resistant alloys, titanium alloys</i> Leghe refrattarie, leghe esotiche, leghe di titanio	10		Zähigkeit Toughness / Tenacità Verschleißbeständigkeit / Wear resistance / Resistenza all'usura	Vorschub Feed rate / Avanzamento Schnittgeschwindigkeit Cutting speed / Velocità di taglio
	20			
	30			
	40			
	50			
H Gehärteter Stahl, Hartguss <i>Hardened steel, hard cast iron</i> Acciaio temprato, ghisa temprata	10		Zähigkeit Toughness / Tenacità Verschleißbeständigkeit / Wear resistance / Resistenza all'usura	Vorschub Feed rate / Avanzamento Schnittgeschwindigkeit Cutting speed / Velocità di taglio
	20			
	30			
	40			
	50			

Hauptanwendungsbereich / Main application area / Applicazione principale



Nebenanwendungsbereich / Secondary application area / Applicazione secondaria

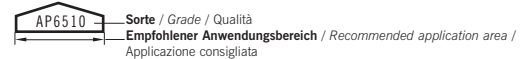

Wendeschneidplatten – CERMET

Indexable inserts – CERMET

Inserti a fissaggio meccanico – CERMET

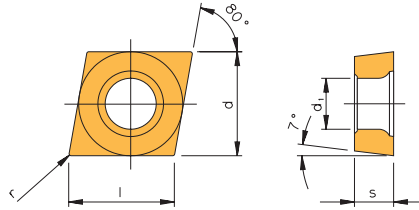

CC..

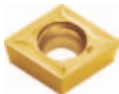
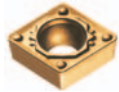
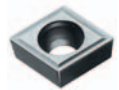
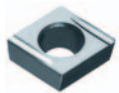

Bezeichnung Designation Articolo	l	d	s	d ₁	r	Sorten / Grades / Gradi			
						beschichtet/ coated/rivestito		unbeschichtet/ uncoated/non rivestito	
						AP6510	AC90C	AP6010	ACE6
CCGT 060201FL-U	6,40	6,350	2,38	2,8	0,1				●
CCGT 060201FR-U	6,40	6,350	2,38	2,8	0,1				●
CCGT 060202FL-U	6,40	6,350	2,38	2,8	0,2	●		●	●
CCGT 060202FR-U	6,40	6,350	2,38	2,8	0,2				●
CCGT 09T302ER-U	9,70	9,525	3,97	4,4	0,2			●	
CCGT 09T302FL-U	9,70	9,525	3,97	4,4	0,2				●
CCGT 09T302FR-U	9,70	9,525	3,97	4,4	0,2				●
CCGT 09T304ER-U	9,70	9,525	3,97	4,4	0,4			●	
CCGT 060201EN	6,40	6,350	2,38	2,8	0,1				●
CCGT 060202EN	6,40	6,350	2,38	2,8	0,2	●		●	●
CCGT 060204EN	6,40	6,350	2,38	2,8	0,4	●	●	●	●
CCGT 09T301EN	9,70	9,525	3,97	4,4	0,1				●
CCGT 09T302EN	9,70	9,525	3,97	4,4	0,2	●			●
CCGT 09T304EN	9,70	9,525	3,97	4,4	0,4	●			●
CCMT 060202EN-AQ	6,40	6,350	2,38	2,8	0,2				●
CCMT 060204EN-AQ	6,40	6,350	2,38	2,8	0,4		●		●
CCMT 09T302EN-AQ	9,70	9,525	3,97	4,4	0,2	●		●	●
CCMT 09T304EN-AQ	9,70	9,525	3,97	4,4	0,4	●	●	●	●
CCMT 09T308EN-AQ	9,70	9,525	3,97	4,4	0,8	●		●	●
CCMT 060202EN-PMC	6,40	6,350	2,38	2,8	0,2	●		●	
CCMT 060204EN-PMC	6,40	6,350	2,38	2,8	0,4	●		●	
CCMT 09T304EN-PMC	9,70	9,525	3,97	4,4	0,4	●			
CCMT 120404EN-PMC	12,90	12,700	4,76	5,5	0,4	●			

- Hauptanwendung
Main application
Applicazione principale
- Nebenanwendung
Secondary application
Applicazione secondaria

P	●	●	●	●
M	●	●	○	●
K				○
N				
S				
H				

5

Wendeschneidplatten – CERMET

Indexable inserts – CERMET

Inserti a fissaggio meccanico – CERMET

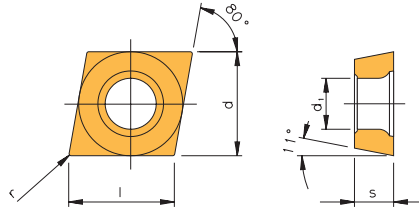

CP..



Bezeichnung Designation Articolo	l	d	s	d ₁	r	Sorten / Grades / Gradi
						unbeschichtet/ uncoated/ non rivestito
CPET 05T102FL	5,60	5,56	1,98	2,5	0,2	●
CPET 05T102FR	5,60	5,56	1,98	2,5	0,2	●
CPGT 05T102EN	5,60	5,56	1,98	2,5	0,2	●
CPGT 05T104EN	5,60	5,56	1,98	2,5	0,4	●
CPMT 05T102EN	5,60	5,56	1,98	2,5	0,2	●

● Hauptanwendung Main application Applicazione principale		P	●
		M	●
○ Nebenanwendung Secondary application Applicazione secondaria		K	○
		N	
		S	
		H	

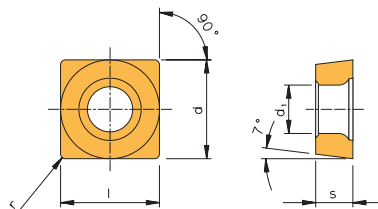

SC..



Bezeichnung Designation Articolo	l	d	s	d ₁	r	Sorten / Grades / Gradi
						unbeschichtet/ uncoated/ non rivestito
SCMT 09T304EN-AQ	9,525	9,525	3,97	4,4	0,4	●
SCMT 09T308EN-AQ	9,525	9,525	3,97	4,4	0,8	●

● Hauptanwendung Main application Applicazione principale		P	●
		M	●
○ Nebenanwendung Secondary application Applicazione secondaria		K	○
		N	
		S	
		H	

5

Wendeschneidplatten – CERMET

Indexable inserts – CERMET

Inserti a fissaggio meccanico – CERMET

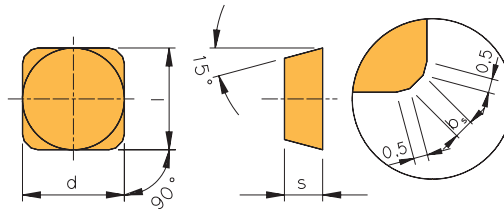

SD..



Bezeichnung Designation Articolo	l	d	s	d ₁	r	b _s	Sorten / Grades / Gradi
							unbeschichtet/ uncoated/ non rivestito
SDKN 1203AUTN	12,70	12,70	3,18	-	-	1,2	ACE6F

● Hauptanwendung Main application Applicazione principale	P	●
	M	●
○ Nebenanwendung Secondary application Applicazione secondaria	K	○
	N	
	S	
	H	

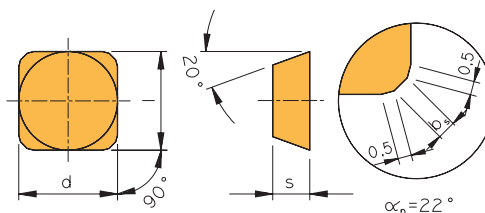

SE..



Bezeichnung Designation Articolo	l	d	s	d ₁	r	b _s	Sorten / Grades / Gradi
							unbeschichtet/ uncoated/ non rivestito
SEKN 1203AFTN	12,7	12,7	3,18	-	-	1,4	ACE6F
SEKN 1204AFTN	12,7	12,7	4,76	-	-	1,4	ACE6F

● Hauptanwendung Main application Applicazione principale	P	●
	M	●
○ Nebenanwendung Secondary application Applicazione secondaria	K	○
	N	
	S	
	H	

5

Wendeschneidplatten – CERMET

Indexable inserts – CERMET

Inserti a fissaggio meccanico – CERMET

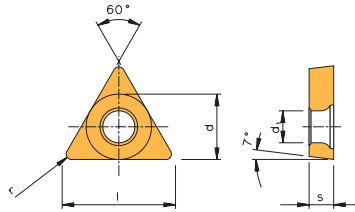

TC..



Bezeichnung Designation Articolo	l	d	s	d ₁	r	Sorten / Grades / Gradi	
						AP6010 unbeschichtet/ uncoated/non rivestito	ACE6
TCGT 110202FL	11,00	6,350	2,38	2,8	0,2		●
TCGT 110204FL	11,00	6,350	2,38	2,8	0,4		●
TCMT 110202EN-AQ	11,00	6,350	2,38	2,8	0,2		●
TCMT 110204EN-AQ	11,00	6,350	2,38	2,8	0,4	●	●
TCMT 110208EN-AQ	11,00	6,350	2,38	2,8	0,8		●
TCMT 16T304EN-AQ	16,50	9,525	3,97	4,4	0,4		●

- Hauptanwendung
Main application
Applicazione principale
- Nebenanwendung
Secondary application
Applicazione secondaria

P	●	●
M	○	●
K		○
N		
S		
H		

- EW

Einweg

- EW

One-way

- EW

Riporto corto

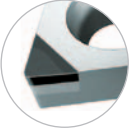

CBN/PKD

- MW

Mehrweg (nachsleifbar)

- MW

Multiple-way (regrindable)

- MW

Riporto Lungo (riaffilatura possibile)

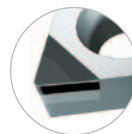

CBN/PKD

- MC

MultiCut (mit zwei Segmenten, Einweg)

- MC

MultiCut (with 2 segments, one-way)

- MC

MultiCut (doppio, riporto corto)

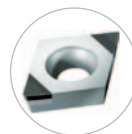

CBN

- WMC

MultiCut Schneidplatte mit WIPER-Geometrie

- WMC



MultiCut insert with WIPER-geometry

- WMC

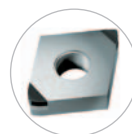
Inserto MultiCut con doppio riporto corto con geometria WIPER

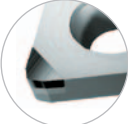

CBN

<p>-W WIPER-Geometrie mit Schleppschneide</p> 	<p>-W <i>WIPER-geometry with trailing edge</i></p>	<p>-W Geometria WIPER con raschiante</p>	<p>PKD</p>	
<p>-PFA Schneidplatte mit feinstgelaserter Spanleitstufe für die Schlicht- und mittlere Zerspanung von NE-Metallen</p> 	<p>-PFA <i>Insert with lasered chip breaker for finish to medium machining of non-ferrous materials</i></p>	<p>-PFA Inserto di riporto con rompitruciolo per finitura e semifinitura di metalli non ferrosi</p>		<p>PKD</p>
<p>-PMA Schneidplatte mit feinstgelaserter Spanleitstufe für die Schrumpferspannung von NE-Metallen</p> 	<p>-PMA <i>Insert with lasered chip breaker for roughing non-ferrous materials</i></p>	<p>-PMA Inserto di riporto con rompitruciolo per sgrassatura di metalli non ferrosi</p>		<p>PKD</p>

Ausführung / Type / Tipologie

Eckenbestückt

Wendeschneidplatte mit eckenbestücktem CBN- oder PKD-Schneidstoff, der untrennbar mit einer entsprechenden Hartmetallunterlage verbunden ist. CBN- und PKD-bestückte Wendeschneidplatten mit Schneidkantenlänge abhängig von der Plattengröße.

Corner brazed

Indexable inserts with CBN or PCD tip, which is brazed on a carbide support pad. The cutting edge length varies with the size of the insert.

Riporto saldobrasato

Inserto di riporto CBN e PCD saldobrasato su base di metallo duro. I riporti in CBN e PCD vengono saldati sulla base con dimensioni in relazione alla base su cui vengono riportati.

Verbund

Schneidstoff besteht aus einer entsprechend dicken CBN- oder PKD-Schicht, die untrennbar mit einer Hartmetallunterlage verbunden ist.

Fullface

Cutting material made from a CBN or PCD, which is brazed on a carbide support pad.

Riporto completo

Riporto di forma di CBN e PCD di dimensione intere dell'inserto su cui vengono riportate.

Unbeschichtet / Uncoated / Non rivestito**AH7510 CBN**

Polykristalline CBN-Sorte mit hohem CBN-Gehalt und Hartmetallunterlage. Feinkorn, sehr hohe Verschleißfestigkeit und Zähigkeit im HSC-Bereich bei GG25 (Superfinish) und hohe Standzeiten bei Superlegierungen. Grauguss (GG25) ($V_c = 500-400$ m/min), Superlegierungen, Sinterstähle.

Polycrystalline Cubic Boron Nitride grade with a high content CBN tip brazed on a micro grain carbide pad. Perfect flank wear resistance and toughness. HSC and super finishing of grey cast iron and finishing of super alloys as well as sintered powder alloys.

Qualität polikristalline CBN rinforzata di carburi con elevati contenuti di Nitruro Cubico di Boro su base metallo duro micrograna, perfetta resistenza all'usura e tenacità. Idonea alla lavorazione ad alta velocità HSC di ghisa grigia (GG25 $V_c = 500-1400$ m/min) e la finitura di leghe esotiche, leghe sinterizzate.

AH7516 CBN

Die neue AH7516 ist eine ultra feinkörnige CBN-Sorte mit spezieller Keramikbindung auf einer Hartmetallunterlage. Ihren Einsatz findet diese Sorte im Finish, bei kontinuierlichem oder leicht unterbrochenem Schnitt von gehärtetem Stahl mit einer Härte von 55 bis 65 HRC. Höchste Prozesssicherheit, dadurch sehr hohe Wirtschaftlichkeit.

The new "AH7516" grade is an ultra fine grain CBN-grade, with a special ceramic mix on a carbide base. The application area is in continuous cutting or light interrupted finishing of hardened steel from 55-65 HRC. Effectively machine materials exceeding 65 HRC is also possible.

La qualità AH7516 è un CBN con speciale legante ceramico da utilizzare nelle operazioni di finitura o lavorazioni di medio taglio interrotto con durezza 55-65 HRC.

AH7520 CBN

Polykristalline CBN-Sorte mit niedrigem CBN-Gehalt und Hartmetallunterlage. Feinkorn, sehr hohe Verschleißfestigkeit, Druckfestigkeit und Zähigkeit beim Hartfräsen (HRC 54-64) im glatten bis mittel unterbrochenen Schnitt bei $R_a 1,6\mu - 3,2\mu$. Hartfräsen, naß und trocken HRC 45-62 für $R_a 1,6\mu - 3,2\mu$ bei $ap 0,05-0,4$ mm, ($V_c = 80-180$ m/min).

Polycrystalline Cubic Boron Nitride grade with a low content CBN tip brazed on a micro grain carbide pad. Excellent wear resistance, compression strength and toughness for hard cutting (54-64 HRC). General purpose for continuous and slightly interrupted cutting at surface finish $R_a 1.6\mu - 3.2\mu$. Finishing of grey cast iron at a very low cutting speeds. Hardened steels (45-62 HRC) in wet and dry cutting applications for $R_a 1.6\mu - 3.2\mu$ with a depth of cut $ap 0.05-0.4$ mm, ($V_c = 80-180$ m/min).

Qualität polikristalline CBN rinforzata di carburi con bassi contenuti di Nitruro Cubico di Boro su base metallo duro micrograna. Eccellente resistenza all'usura, resistenza alla compressione e tenacità per la lavorazione di materiali duri (HRC 54-64). Applicazioni generiche per taglio continuo o leggermente interrotto per rugosità superficiali $R_a 1,6-3,2$ e finitura di ghisa grigia a ridotte velocità di taglio. Acciai temprati (HRC 45-62) lavorati a secco e con refrigerante per $R_a 1,6-3,2$ ed $ap = 0,05-0,4$ mm, ($V_c = 80-180$ m/min).

AN8020 PKD

Polykristalliner Diamant mit Hartmetallunterlage, Mittelkorn, gute Schneidenschärfe und geringer Schnittdruck bei engen Toleranzen. Gute Verschleißfestigkeit und Zähigkeit. Schlichten bis Schruppen aller NE-Werkstoffe mit hoher Schnittgeschwindigkeit.

Polycrystalline, carbide reinforced diamond on medium grain carbide pad. Good cutting edge sharpness and low cutting forces allow small tolerance machining. Increased wear resistance and toughness. Finishing and general purpose machining of all non-ferrous metals at high cutting speeds.

Qualität di diamante polikristallino a grana media rinforzata di carburi su base metallo duro. Buona stabilità del filo tagliente e ridotte forze di taglio assicurano esecuzioni a basse tolleranze. Incrementata resistenza all'usura e tenacità. Finitura e generiche applicazioni di metalli non ferrosi ad alte velocità di taglio.

ISO	CBN/PKD CBN/PCD CBN/PCD	Schneidstoff Cutting material Materiale da taglio	Anwendung Application Parametri
P Stahl, Stahlguss, langspanender Temperguss <i>Steel, cast steel, malleable iron</i> Acciaio, acciaio da fusione, ghisa malleabile da truciolo lungo	10		Zähigkeit Toughness / Tenacità Verschleißbeständigkeit / Wear resistance / Resistenza all'usura Vorschub Feed rate / Avanzamento Schnittgeschwindigkeit Cutting speed / Velocità di taglio
	20		
	30		
	40		
	50		
M Rostfreier Stahl, Stahlguss, Manganstahl, Automatenstahl <i>Stainless steel, cast steel, manganese steel, free cutting steel</i> Acciaio Inossidabile, Acciaio da Fusione, Acciaio al Manganese, Acciaio Automatico	10		Zähigkeit Toughness / Tenacità Verschleißbeständigkeit / Wear resistance / Resistenza all'usura Vorschub Feed rate / Avanzamento Schnittgeschwindigkeit Cutting speed / Velocità di taglio
	20		
	30		
	40		
	50		
K Grauguss, Kokillenhartguss, kurzspanender Temperguss <i>Grey cast iron, chilled hard cast iron, short chipping malleable iron</i> Ghisa grigia, ghisa sferoidale, ghisa malleabile a truciolo corto	10		Zähigkeit Toughness / Tenacità Verschleißbeständigkeit / Wear resistance / Resistenza all'usura Vorschub Feed rate / Avanzamento Schnittgeschwindigkeit Cutting speed / Velocità di taglio
	20		
	30		
	40		
	50		
N Aluminium und Al-Legierungen, nichtmetallische Werkstoffe <i>Aluminum and Al-alloys, non-ferrous materials</i> Alluminio e sue leghe, materiali non ferrosi o non metallici	10		Zähigkeit Toughness / Tenacità Verschleißbeständigkeit / Wear resistance / Resistenza all'usura Vorschub Feed rate / Avanzamento Schnittgeschwindigkeit Cutting speed / Velocità di taglio
	20		
	30		
	40		
	50		
S Warmfeste Legierungen, Titanlegierungen <i>High temperature resistant alloys, titanium alloys</i> Leghe refrattarie, leghe esotiche, leghe di titanio	10		Zähigkeit Toughness / Tenacità Verschleißbeständigkeit / Wear resistance / Resistenza all'usura Vorschub Feed rate / Avanzamento Schnittgeschwindigkeit Cutting speed / Velocità di taglio
	20		
	30		
	40		
	50		
H Gehärteter Stahl, Hartguss <i>Hardened steel, hard cast iron</i> Acciaio temprato, ghisa temprata	10		Zähigkeit Toughness / Tenacità Verschleißbeständigkeit / Wear resistance / Resistenza all'usura Vorschub Feed rate / Avanzamento Schnittgeschwindigkeit Cutting speed / Velocità di taglio
	20		
	30		
	40		
	50		

Hauptanwendungsbereich / Main application area / Applicazione principale



Nebenanwendungsbereich / Secondary application area / Applicazione secondaria



Die ARNO Fräser aus pulvermetallurgischem HSS Stahl sind extrem robust und verschleißfest. TiAlN/TiCN beschichtet erzielen Sie beste Leistungen bei der Zerspanung.

The ARNO powder metal cutters are extremely tough and wear resistant. Available with TiAlN/TiCN coating for excellent performance.

Le frese ARNO in HSS-PM sinterizzate sono estremamente resistenti all'usura e garantiscono prolungate vite utensile. I rivestimenti TiAlN/TiCN garantiscono migliori prestazioni in lavorazione.



ARNO® PM-HSS FRÄSER

Ob Universalfräser für die Bearbeitung von Stahl, rostfreiem Stahl oder Gusswerkstoffen: Bei den ARNO PM-HSS Fräsern erwarten Sie hohe Oberflächenqualitäten bei maximaler Schnittleistung.

No matter whether machining steel, stainless steel, cast materials or exotics, the ARNO PM cutters provide both good surface finish and tool performance.

La fresa universale per la lavorazione di acciaio, acciaio inossidabile o ghisa: le frese ARNO PM-HSS garantiscono elevata finitura superficiale con la massima prestazione di taglio.

Weitere ARNO Highlights finden Sie unter:

For further ARNO highlights please see:
Per ulteriori informazioni visitate il nostro sito:

www.arno.de

Wendeschneidplatten – Hochharte Schneidstoffe

Indexable inserts – Ultra-hard cutting materials

Inserti a fissaggio meccanico – Materiali Extra duri

CCGT..

Einweg – PKD

One-way – PCD

Riporto corto – PKD

gelaserte Spanleitstufe

Laser cut chip breaker

Rompitruciolo formato a laser

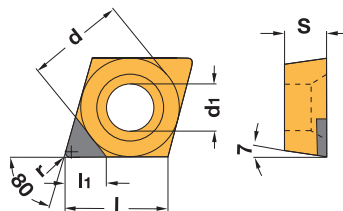

Bezeichnung Designation Articolo	d	d ₁	s	l	l _{1min}	r	Sorten / Grades / Gradi
							AN8020
CCGT 060202FN-PFA	6,35	2,8	2,38	6,45	3,0	0,2	●
CCGT 060204FN-PFA	6,35	2,8	2,38	6,45	3,0	0,4	●
CCGT 09T302FN-PFA	9,52	4,4	3,97	9,70	4,0	0,2	●
CCGT 09T304FN-PFA	9,52	4,4	3,97	9,70	4,0	0,4	●
CCGT 09T308FN-PFA	9,52	4,4	3,97	9,70	4,0	0,8	●
CCGT 060202FN-PMA	6,35	2,8	2,38	6,45	3,0	0,2	●
CCGT 060204FN-PMA	6,35	2,8	2,38	6,45	3,0	0,4	●
CCGT 09T302FN-PMA	9,52	4,4	3,97	9,70	4,0	0,2	●
CCGT 09T304FN-PMA	9,52	4,4	3,97	9,70	4,0	0,4	●
CCGT 09T308FN-PMA	9,52	4,4	3,97	9,70	4,0	0,8	●

- **Hauptanwendung**
Main application
Applicazione principale
- **Nebenanwendung**
Secondary application
Applicazione secondaria

P	
M	
K	
N	●
S	
H	

CCGT..

Mehrweg – PKD

Multiple way – PCD

Riporto lungo – PKD

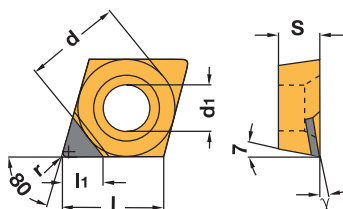

Bezeichnung Designation Articolo	d	d ₁	s	l	l _{1min}	r	γ	Sorten / Grades / Gradi
								AN8020
CCGT 060202FN-MW	6,35	2,8	2,38	6,45	3,0	0,2	7°	●
CCGT 060204FN-MW	6,35	2,8	2,38	6,45	3,0	0,4	7°	●
CCGT 09T304FN-MW	9,52	4,4	3,97	9,7	4,0	0,4	10°	●
CCGT 120404FN-MW	12,7	5,5	4,76	12,9	4,0	0,4	10°	●

- **Hauptanwendung**
Main application
Applicazione principale
- **Nebenanwendung**
Secondary application
Applicazione secondaria

P	
M	
K	
N	●
S	
H	

Sorten / Grades / Gradi

AH... → CBN

AN... → PKD/PCD

Alle Angaben in mm / Dimensions in mm / Tutte le dimensioni in mm

ARNO®-Werkzeuge | Fräsen | Milling | Fresatura

Wendeschneidplatten – Hochharte Schneidstoffe

Indexable inserts – Ultra-hard cutting materials

Inserti a fissaggio meccanico – Materiali Extra duri

CCGW..

Einweg – CBN

One-way – CBN

Riporto corto – CBN

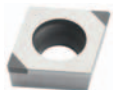
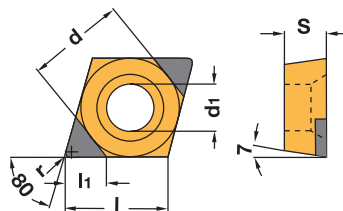

Bezeichnung Designation Articolo	d	d ₁	s	l	l _{1min}	r	Sorten / Grades / Gradi		
							AH7510	AH7516	AH7520
CCGW 060202TN-MC	6,35	2,8	2,38	6,45	2,5 (2x)	0,2	●	●	●
CCGW 060204TN-MC	6,35	2,8	2,38	6,45	2,5 (2x)	0,4	●	●	●
CCGW 09T302FN-MC	9,52	4,4	3,97	9,7	2,5 (2x)	0,2	●	●	●
CCGW 09T302TN-MC	9,52	4,4	3,97	9,7	2,5 (2x)	0,2	●	●	●
CCGW 09T304FN-MC	9,52	4,4	3,97	9,7	2,5 (2x)	0,4	●	●	●
CCGW 09T304TN-MC	9,52	4,4	3,97	9,7	2,5 (2x)	0,4	●	●	●
CCGW 09T308TN-MC	9,52	4,4	3,97	9,7	2,5 (2x)	0,8	●	●	●

- **Hauptanwendung**
Main application
Applicazione principale
- **Nebenanwendung**
Secondary application
Applicazione secondaria

	P	M	K	N	S	H
● Hauptanwendung						
○ Nebenanwendung			●			
					●	
						●

CCGW..

Mehrweg – CBN/PKD

Multiple way – CBN/PCD

Riporto lungo – CBN/PKD

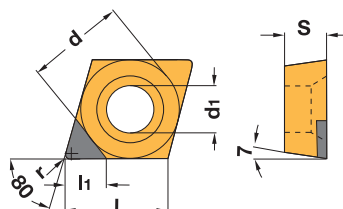

Bezeichnung Designation Articolo	d	d ₁	s	l	l _{1min}	r	Sorten / Grades / Gradi		
							AH7510	AH7520	AN8020
CCGW 060202FN-MW	6,35	2,8	2,38	6,45	2,5	0,2	●	●	●
CCGW 060202TN-MW	6,35	2,8	2,38	6,45	2,5	0,2	●	●	
CCGW 060204FN-MW	6,35	2,8	2,38	6,45	2,5	0,4	●	●	●
CCGW 060204TN-MW	6,35	2,8	2,38	6,45	2,5	0,4	●	●	
CCGW 09T302FN-MW	9,52	4,4	3,97	9,7	2,5	0,2		●	●
CCGW 09T304FN-MW	9,52	4,4	3,97	9,7	2,5	0,4		●	●
CCGW 09T308FN-MW	9,52	4,4	3,97	9,7	2,5	0,8			●
CCGW 120404FN-MW	12,70	5,5	4,76	12,9	4,0	0,4			●

- **Hauptanwendung**
Main application
Applicazione principale
- **Nebenanwendung**
Secondary application
Applicazione secondaria

	P	M	K	N	S	H
● Hauptanwendung						
○ Nebenanwendung			●			
					●	
						●

Sorten / Grades / Gradi

AH... → CBN

AN... → PKD/PCD

Wendeschneidplatten – Hochharte Schneidstoffe

Indexable inserts – Ultra-hard cutting materials

Inserti a fissaggio meccanico – Materiali Extra duri

CCGW..

Einweg – CBN/PKD

One-way – CBN/PCD

Riporto corto – CBN/PKD

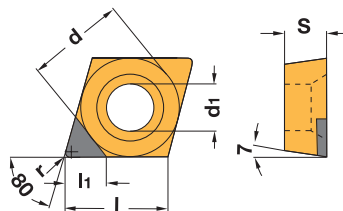

Bezeichnung Designation Articolo	d	d ₁	s	l	l _{1min}	r	Sorten / Grades / Gradi		
							AH7516	AH7520	AN8020
CCGW 060204TN-EW	6,35	2,8	2,38	6,45	2,5	0,4	●	●	
CCGW 09T304FN-EW	9,52	4,4	3,97	9,7	2,5	0,4		●	●
CCGW 09T304TN-EW	9,52	4,4	3,97	9,7	2,5	0,4	●	●	
CCGW 09T308FN-EW	9,52	4,4	3,97	9,7	2,5	0,8		●	
CCGW 09T308TN-EW	9,52	4,4	3,97	9,7	2,5	0,8		●	
CCGW 120404FN-EW	12,7	5,5	4,76	12,9	2,5	0,4		●	●
CCGW 120404TN-EW	12,7	5,5	4,76	12,9	2,5	0,4		●	●
CCGW 120408TN-EW	12,7	5,5	4,76	12,9	2,5	0,8		●	
CCGW 09T304FN-W	9,52	4,4	3,97	9,7	2,5	0,4			●

- Hauptanwendung
Main application
Applicazione principale
- Nebenanwendung
Secondary application
Applicazione secondaria

P		
M		
K		
N		●
S		
H	●	●

CPGT..

Mehrweg – CBN

Multiple way – CBN

Riporto lungo – CBN

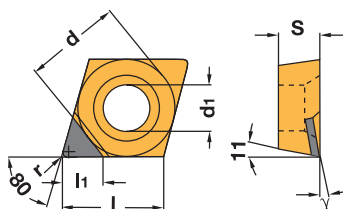

Bezeichnung Designation Articolo	d	d ₁	s	l	l _{1min}	r	γ	Sorten / Grades / Gradi
								AH7520
CPGT 05T102FN-MW	5,56	2,5	1,98	5,6	2,5	0,2	7°	●

- Hauptanwendung
Main application
Applicazione principale
- Nebenanwendung
Secondary application
Applicazione secondaria

P	
M	
K	
N	
S	
H	●

Sorten / Grades / Gradi

AH... → CBN

AN... → PKD/PCD

Alle Angaben in mm / Dimensions in mm / Tutte le dimensioni in mm

ARNO®-Werkzeuge | Fräsen | Milling | Fresatura

Wendeschneidplatten – Hochharte Schneidstoffe

Indexable inserts – Ultra-hard cutting materials

Inserti a fissaggio meccanico – Materiali Extra duri

CPGW..

Mehrweg – CBN

Multiple way – CBN

Riporto lungo – CBN

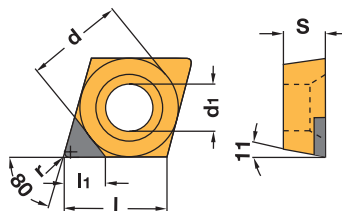

Bezeichnung Designation Articolo	d	d ₁	s	l	l _{1min}	r	Sorten / Grades / Gradi		
							AH7510	AH7516	AH7520
CPGW 05T102FN-MW	5,56	2,5	1,98	5,6	2,5	0,2	●	●	●
CPGW 05T102TN-MW	5,56	2,5	1,98	5,6	2,5	0,2	●		●
CPGW 05T104FN-MW	5,56	2,5	1,98	5,6	2,5	0,4	●	●	●

- Hauptanwendung
Main application
Applicazione principale
- Nebenanwendung
Secondary application
Applicazione secondaria

	P	M	K	N	S	H
● Hauptanwendung			●		●	●
○ Nebenanwendung						

CPGW..

Einweg – CBN

One-way – CBN

Riporto corto – CBN

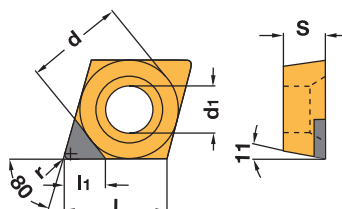

Bezeichnung Designation Articolo	d	d ₁	s	l	l _{1min}	r	Sorten / Grades / Gradi
							AH7520
CPGW 05T104TN-EW	5,56	2,5	1,98	5,6	2,0	0,4	●

- Hauptanwendung
Main application
Applicazione principale
- Nebenanwendung
Secondary application
Applicazione secondaria

	P	M	K	N	S	H
● Hauptanwendung						
○ Nebenanwendung						●

Sorten / Grades / Gradi

AH... → CBN

AN... → PKD/PCD

Wendeschneidplatten – Hochharte Schneidstoffe

Indexable inserts – Ultra-hard cutting materials

Inserti a fissaggio meccanico – Materiali Extra duri

TCGT..

Mehrweg – PKD

Multiple way – PCD

Riporto lungo – PKD

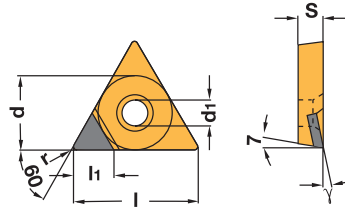

Bezeichnung Designation Articolo	d	d ₁	s	l	l _{1min}	r	γ	Sorten / Grades / Gradi	
								AH7520	AN8020
TCGT 16T304FN-MW	9,52	4,4	3,97	16,5	4,0	0,4	10°	●	●

- **Hauptanwendung**
Main application
Applicazione principale
- **Nebenanwendung**
Secondary application
Applicazione secondaria

P	
M	
K	
N	●
S	
H	

TCGW..

Mehrweg – CBN/PKD

Multiple way – CBN/PCD

Riporto lungo – CBN/PKD

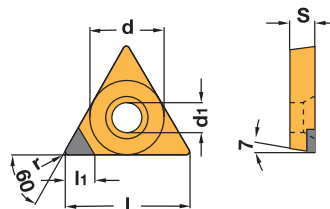

Bezeichnung Designation Articolo	d	d ₁	s	l	l _{1min}	r	Sorten / Grades / Gradi	
							AH7520	AN8020
TCGW 090202FN-MW	5,56	2,5	2,38	9,6	3,0	0,2		●
TCGW 090204FN-MW	5,56	2,5	2,38	9,6	3,0	0,4		●
TCGW 110202FN-MW	6,35	2,8	2,38	11	4,0	0,2		●
TCGW 110204FN-MW	6,35	2,8	2,38	11	4,0	0,4	●	●
TCGW 16T304FN-MW	9,52	4,4	3,97	16,5	4,0	0,4		●
TCGW 16T308FN-MW	9,52	4,4	3,97	16,5	4,0	0,8		●

- **Hauptanwendung**
Main application
Applicazione principale
- **Nebenanwendung**
Secondary application
Applicazione secondaria

P		
M		
K		
N		●
S		
H	●	

Sorten / Grades / Gradi

AH... → CBN

AN... → PKD/PCD

Alle Angaben in mm / Dimensions in mm / Tutte le dimensioni in mm

Wendeschneidplatten – Hochharte Schneidstoffe

Indexable inserts – Ultra-hard cutting materials

Inserti a fissaggio meccanico – Materiali Extra duri

TCGW..

Einweg – CBN/PKD

One-way – CBN/PCD

Riporto corto – CBN/PKD

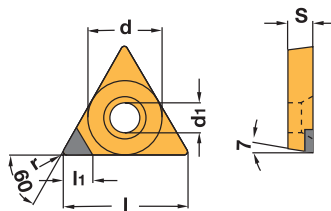

Bezeichnung Designation Articolo	d	d ₁	s	l	l _{min}	r	Sorten / Grades / Gradi	
							AH7520	AN8020
TCGW 110204TN-EW	6,35	2,8	2,38	11,0	2,5	0,4	●	
TCGW 16T304FN-EW	9,52	4,4	3,97	16,5	2,5	0,4		●

- **Hauptanwendung**
Main application
Applicazione principale
- **Nebenanwendung**
Secondary application
Applicazione secondaria

P		
M		
K		
N		●
S		
H	●	

Sorten / Grades / Gradi

AH... → CBN

AN... → PKD/PCD

Beschichtet / Coated / Rivestito**HSS-TiN****PVD-Mehrlagenbeschichtung**

Ergänzende Sorte zu den Hartmetallen für die Bearbeitung im unteren Schnittgeschwindigkeitsbereich, in denen höchste Zähigkeit gefordert ist. Einsatz bei ungünstigen Bearbeitungsbedingungen (z. B. unterbrochener Schnitt, Krusten, Schmiedehaut) und schwer zerspanbaren Werkstoffen. Sehr gute Ergebnisse auch bei Aluminium, Knet- und Gusslegierungen, Titan und Titanlegierungen, Nickellegierungen, Kupfer, Messing und Bronze. Große Spanquerschnitte. Sehr hohe Zähigkeit der Schneide. Geringer Verschleiß durch die TiN-Hartstoffbeschichtung.

PVD-multilayer coating

Supplementary grade to carbide grades for machining at lower cutting speeds where high toughness is required. For use under unfavorable machining conditions (e. g. interrupted cutting, forged skin) and difficult to machine materials. Also suitable for machining aluminum-wrought and casting alloy, nickel alloy, copper, brass and bronze. Large chip cross sections. Very high toughness on the cutting edge. Less wear due to TiN coating.

Rivestimento PVD-multistrato

Spessore del rivestimento 1–4µ Qualità aggiunta alle qualità di metallo duro per lavorazioni a basse velocità di taglio dove è richiesta elevata tenacità. Per applicazioni in condizioni sfavorevoli di lavorazione (p. es: taglio interrotto, croste di forgiatura) e materiali difficili da lavorare come Inconell, Hastelloy o Nimonic. Per grosse asportazioni ha un tagliente molto tenace e ridotta usura grazie al rivestimento TiN.

HSS-TiAlN**PVD-Mehrlagenbeschichtung**

Ergänzende Sorte zu den Hartmetallen. Für die Hochleistungsbearbeitung geeignet. Nass- und Trockenbearbeitung von Stahl, rostfreiem Stahl und Guss (GG, GGG) sowie schwer zerspanbaren Werkstoffen möglich. Die TiAlN Hartstoffschichten zeichnen sich durch eine hohe Zähigkeit des Schichtaufbaues, hohe Schnittgeschwindigkeiten sowie hohe thermische und chemische Stabilität aus.

PVD-multilayer coating

Supplementary grade to carbide grades. Recommended for high performance machining. Wet and dry machining of steel, stainless steel and cast iron as well as difficult to machine materials. The TiAlN hard material coating offers high toughness, high cutting speed as well as maximum thermal and chemical stress protection.

Rivestimento PVD-multistrato

Spessore del rivestimento 2–5µ Qualità di HSS suggerita per lavorazioni con elevate prestazioni. Idoneo sia a secco che con refrigerante, acciaio inossidabile e ghisa GG e GGG. Utilizzabile anche per la lavorazione di Alluminio, leghe da fusione e grezze, leghe di Nichel, Rame, Ottone, Bronzo. Il rivestimento TiAlN grazie alla sua durezza offre una elevata durezza superficiale per alte velocità di taglio così come in applicazioni dove è richiesta massima dissipazione termica e protezione chimica.

Schnell, flexibel und individuell.

Quick, flexible and individual.

Veloce, flessibile e individuale.

- **Wir bieten Ihnen Sonderlösungen für Ihre individuellen Bedürfnisse.**
 - **Bestellen Sie bis 18 Uhr unsere Produkte, erhalten Sie Ihre Lieferung bereits am nächsten Tag.**
 - **Da wir Konstruktion, Produktion und Vertrieb unter einem Dach vereinen, können wir eine hohe Qualität unserer Produkte garantieren.**
 - **Die Mitarbeiter unseres Außendienstes besuchen Sie regelmäßig und unterstützen Sie mit ihrem Produktwissen.**
 - **Unsere Anwendungstechniker beraten Sie direkt vor Ort in Ihrem Werk.**
 - **Die kompetenten ARNO-Ansprechpartner stehen Ihnen bei Fragen und Anliegen gerne zur Verfügung – weltweit.**
- *We offer special solutions for your individual requirement.*
 - *Order your products by 15.30 CET for same day dispatch.*
 - *As we design, manufacture, and service our own products, we offer you only top quality products.*
 - *Our external sales engineers will be visiting regularly.*
 - *Our trained engineers are experienced and will be able to help you with most applications.*
 - *Our competent global ARNO-partners are always available to answer any questions you may have.*
- Offriamo soluzioni speciali per le vostre esigenze.
 - Ordinate i nostri prodotti entro le 15,30 e li avrete il giorno dopo.
 - Possiamo offrirvi la massima qualità avendo produzione, progettazione e vendita in un unico posto.
 - Verete visitati regolarmente dai nostri collaboratori.
 - I nostri tecnici sapranno consigliarvi per il meglio.
 - Tutto il team ARNO è a vostra completa disposizione.



Weitere Informationen finden Sie unter:

For more information see:

Altre informazioni sotto:

www.arno.de

Wendeschneidplatten – HSS Schneidstoff

Indexable inserts – HSS cutting material

Inserti a fissaggio meccanico – Acciaio Super Rapido

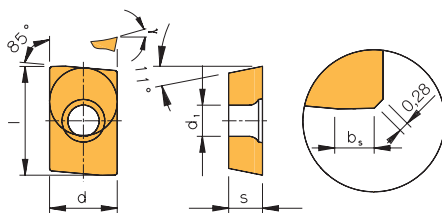

AOFT..



Bezeichnung Designation Articolo	l	d	s	d ₁	b _s	γ	Sorten / Grades / Gradi	
							HSS-TiN	HSS-TiAlN
AOFT 15T308FR	14,50	8,8	4,2	3,8	r 0,8	25°	●	●
AOFT 15T3PFFR	14,50	8,8	4,2	3,8	0,2 x 45°	25°	●	●
AOFT 200408FR	19,40	11,0	4,76	4,5	r 0,8	20°	●	●
AOFT 2004PFFR	19,40	11,0	4,76	4,5	0,2 x 45°	20°	●	●
AOFT 15T308FR-3-25	14,50	8,8	4,2	3,8	r 0,8	25°	●	●
AOFT 15T3PFFR-1/2-25	14,50	8,8	4,2	3,8	0,2 x 45°	25°	●	●
AOFT 200408FR-3-20	19,40	11,0	4,76	4,5	r 0,8	20°	●	●
AOFT 2004PFFR-1/2-20	19,40	11,0	4,76	4,5	0,2 x 45°	20°	●	●

- Hauptanwendung
Main application
Applicazione principale
- Nebenanwendung
Secondary application
Applicazione secondaria

	P	M	K	N	S	H
HSS-TiN	●	●			○	
HSS-TiAlN		●				

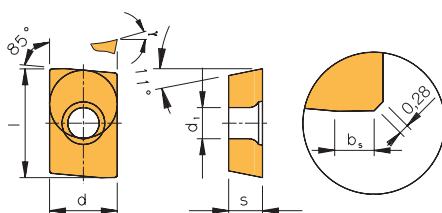

APFT..

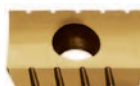

Bezeichnung Designation Articolo	l	d	s	d ₁	b _s	γ	Sorten / Grades / Gradi	
							HSS-TiN	HSS-TiAlN
APFT 1604PDFR-18	16,7	9,52	4,76	4,5	0,2x45°	18°30'		●
APFT 1604PDFR-25	16,7	9,52	4,76	4,5	0,2x45°	25°30'		●
APFT 160404FL	17,0	9,52	4,76	4,5	r 0,4	18°30'	●	
APFT 160404FR	17,0	9,52	4,76	4,5	r 0,4	18°30'	●	●
APFT 160408FL	17,0	9,52	4,76	4,5	r 0,8	18°30'	●	
APFT 160408FR	17,0	9,52	4,76	4,5	r 0,8	18°30'	●	●
APFT 160412FL	17,0	9,52	4,76	4,5	r 1,2	18°30'	●	
APFT 160412FR	17,0	9,52	4,76	4,5	r 1,2	18°30'	●	●
APFT 1605PDFR	16,7	9,52	5,56	4,7	0,2x45°	29°		●
APFT 1604PDFL-3-18	16,7	9,52	4,76	4,5	0,2x45°	18°30'	●	
APFT 1604PDR-3-18	16,7	9,52	4,76	4,5	0,2x45°	18°30'		●
APFT 1604PDR-3-25	16,7	9,52	4,76	4,5	0,2x45°	25°30'	●	
APFT 1604PDR-1/2-18	16,7	9,52	4,76	4,5	0,2x45°	18°30'	●	●
APFT 1604PDR-1/2-25	16,7	9,52	4,76	4,5	0,2x45°	25°30'	●	●

- Hauptanwendung
Main application
Applicazione principale
- Nebenanwendung
Secondary application
Applicazione secondaria

	P	M	K	N	S	H
HSS-TiN	●	●			○	
HSS-TiAlN		●				

Wendeschneidplatten – HSS Schneidstoff

Indexable inserts – HSS cutting material

Inserti a fissaggio meccanico – Acciaio Super Rapido

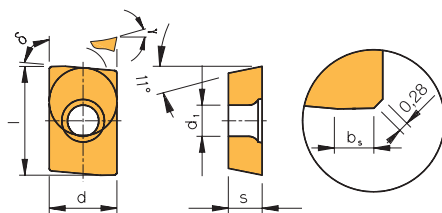

BPFT..



Bezeichnung Designation Articolo	l	d	s	d ₁	b _s	γ	Sorten / Grades / Gradi	beschichtet/ coated/ rivestito
							HSS-TiN	
BPFT 1604PDFR	15,8	9,52	4,76	4,5	0,2x45°	22°	●	●

- **Hauptanwendung**
Main application
Applicazione principale
- **Nebenanwendung**
Secondary application
Applicazione secondaria

P	●
M	●
K	
N	
S	○
H	

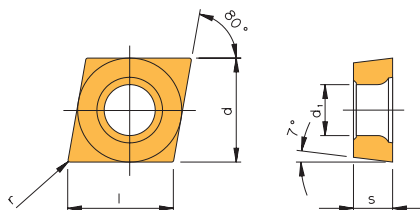

CCFT..

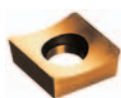

Bezeichnung Designation Articolo	l	d	s	d ₁	r	γ	Sorten / Grades / Gradi	beschichtet/ coated/ rivestito
							HSS-TiN	
CCFT 060201FL-G	6,4	6,350	2,38	3,0	0,1	20°	●	●
CCFT 060201FR-G	6,4	6,350	2,38	3,0	0,1	20°	●	●
CCFT 060202FL-G	6,4	6,350	2,38	3,0	0,2	20°	●	●
CCFT 060202FR-G	6,4	6,350	2,38	3,0	0,2	20°	●	●
CCFT 060204FL-G	6,4	6,350	2,38	3,0	0,4	20°	●	●
CCFT 060204FR-G	6,4	6,350	2,38	3,0	0,4	20°	●	●
CCFT 09T304FL-G	9,7	9,525	3,96	4,5	0,4	25°	●	●
CCFT 09T304FR-G	9,7	9,525	3,96	4,5	0,4	25°	●	●
CCFT 09T308FL-G	9,7	9,525	3,96	4,5	0,8	25°	●	●
CCFT 09T308FR-G	9,7	9,525	3,96	4,5	0,8	25°	●	●
CCFT 060202FL-K	6,4	6,350	2,38	3,0	0,2	30°	●	●
CCFT 060202FR-K	6,4	6,350	2,38	3,0	0,2	30°	●	●
CCFT 060204FL-K	6,4	6,350	2,38	3,0	0,4	30°	●	●
CCFT 09T304FL-K	9,7	9,525	3,96	4,5	0,4	30°	●	●
CCFT 09T304FR-K	9,7	9,525	3,96	4,5	0,4	30°	●	●
CCFT 09T308FL-K	9,7	9,525	3,96	4,5	0,8	30°	●	●
CCFT 09T308FR-K	9,7	9,525	3,96	4,5	0,8	30°	●	●

- **Hauptanwendung**
Main application
Applicazione principale
- **Nebenanwendung**
Secondary application
Applicazione secondaria

P	●
M	●
K	
N	
S	○
H	

5

Wendeschneidplatten – HSS Schneidstoff

Indexable inserts – HSS cutting material

Inserti a fissaggio meccanico – Acciaio Super Rapido

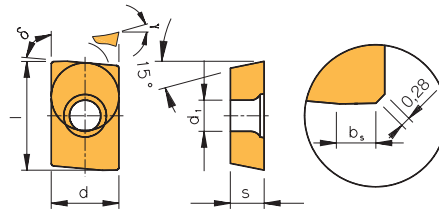

LDFT..



Bezeichnung Designation Articolo	l	d	s	d ₁	b _s	γ	Sorten / Grades / Gradi	
							HSS-TiN	HSS-TiAlN
LDFT 1503PDFR-86	15,0	9,52	3,18	4,5	0,2x45°	14°	●	●
LDFT 1503PDFR-88	15,0	9,52	3,18	4,5	0,2x45°	15°	●	●
LDFT 15T3PDFR	15,0	9,52	3,97	4,5	0,2x45°	15°	●	●

- Hauptanwendung
Main application
Applicazione principale
- Nebenanwendung
Secondary application
Applicazione secondaria

P	●	●
M	●	●
K		
N		
S	○	○
H		

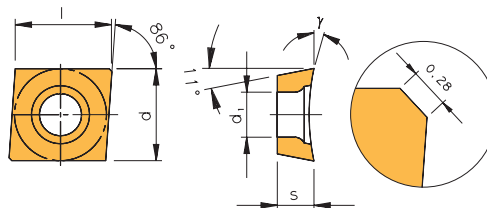

MPFT..



Bezeichnung Designation Articolo	l	d	s	d ₁	b _s	γ	Sorten / Grades / Gradi	
							HSS-TiN	HSS-TiAlN
MPFT 0402PPFR	4,7	4,76	2,38	2,4	0,2x45°	18°30'	●	●
MPFT 0602PPFR	6,3	6,35	2,38	3,0	0,2x45°	18°30'	●	●
MPFT 080308FR	8,0	7,94	3,18	3,4	0,2x45°	18°30'	●	●
MPFT 0803PPFR	8,0	7,94	3,18	3,4	0,2x45°	18°30'	●	●
MPFT 1104PPFR	11,15	11,11	4,76	4,5	0,2x45°	18°30'	●	●

- Hauptanwendung
Main application
Applicazione principale
- Nebenanwendung
Secondary application
Applicazione secondaria

P	●	●
M	●	●
K		
N		
S	○	○
H		

Wendeschneidplatten – HSS Schneidstoff

Indexable inserts – HSS cutting material

Inserti a fissaggio meccanico – Acciaio Super Rapido

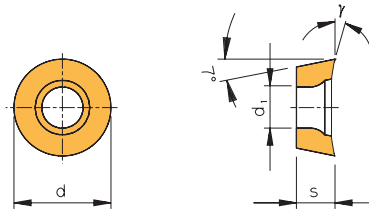

RCFT..



Bezeichnung Designation Articolo	l	d	s	d ₁	r	γ	Sorten / Grades / Gradi	
							HSS-TiN	beschichtet/ coated/ rivestito
RCFT 0602MOFN	-	6	2,38	3,0	-	25°	●	●
RCFT 0803MOFN	-	8	3,18	3,6	-	25°	●	●
RCFT 10T3MOFN	-	10	3,97	4,5	-	25°	●	●
RCFT 1204MOFN	-	12	4,76	5,5	-	25°	●	●
RCFT 1606MOFN	-	16	6,35	5,5	-	25°	●	●
RCFT 2006MOFN	-	20	6,35	6,5	-	25°	●	●

- **Hauptanwendung**
Main application
Applicazione principale
- **Nebenanwendung**
Secondary application
Applicazione secondaria

P	●
M	●
K	
N	
S	○
H	

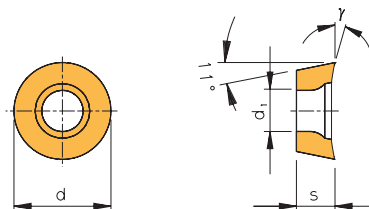

RPFT..



Bezeichnung Designation Articolo	l	d	s	d ₁	r	γ	Sorten / Grades / Gradi	
							HSS-TiN	HSS-TiAlN beschichtet/ coated/rivestito
RPFT 0602MOFN	-	6,0	2,38	3,0	-	20°	●	●
RPFT 0803MOFN-40	-	8,0	3,18	3,6	-	20°	●	●
RPFT 10T3MOFN	-	10,0	3,97	4,5	-	20°	●	
RPFT 120400FN-20	-	12,7	4,76	5,5	-	20°	●	
RPFT 1204MOFN-30	-	12,0	4,76	5,5	-	24°	●	

- **Hauptanwendung**
Main application
Applicazione principale
- **Nebenanwendung**
Secondary application
Applicazione secondaria

P	●	●
M	●	●
K		
N		
S	○	○
H		

5

Wendeschneidplatten – HSS Schneidstoff

Indexable inserts – HSS cutting material

Inserti a fissaggio meccanico – Acciaio Super Rapido

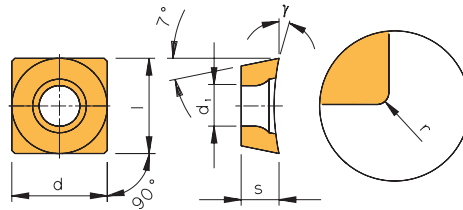

SCFT..



Bezeichnung Designation Articolo	l	d	s	d ₁	r	γ	Sorten / Grades / Gradi	
							HSS-TiN	HSS-TiAlN
SCFT 090404FN	9,525	9,525	4,00	4,5	0,4	25°	●	●
SCFT 090408FN	9,525	9,525	4,00	4,5	0,8	25°	●	●
SCFT 120504FN	12,83	12,83	5,56	5,5	0,4	24°	●	●
SCFT 120508FN	12,83	12,83	5,56	5,5	0,8	24°	●	●
SCFT 120512FN	12,83	12,83	5,56	5,5	1,2	24°	●	●
SCFT 090408FN-K	9,525	9,525	4,00	4,5	0,8	30°	●	
SCFT 120504FN-K	12,83	12,83	5,56	5,5	0,4	30°	●	
SCFT 120512FN-K	12,83	12,83	5,56	5,5	1,2	30°	●	
SCFT 1205ACFN	12,83	12,83	5,56	5,5	0,2x45°	24°	●	●

- **Hauptanwendung**
Main application
Applicazione principale
- **Nebenanwendung**
Secondary application
Applicazione secondaria

P	●	●
M	●	●
K		
N		
S	○	○
H		

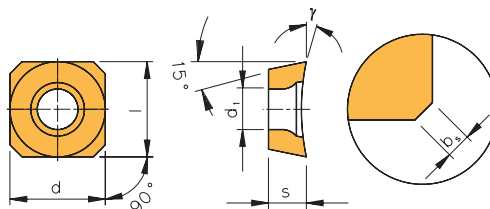

SDFT..



Bezeichnung Designation Articolo	l	d	s	d ₁	b ₁	γ	Sorten / Grades / Gradi	
							HSS-TiN	HSS-TiAlN
SDFT 09T3AEFN	9,52	9,52	3,97	4,5	1,2x45° R0,8	17°	●	●
SDFT 1204AEFN	12,70	12,70	4,76	5,5	1,5x45° R0,8	17°	●	●

- **Hauptanwendung**
Main application
Applicazione principale
- **Nebenanwendung**
Secondary application
Applicazione secondaria

P	●	●
M	●	●
K		
N		
S	○	○
H		

Wendeschneidplatten – HSS Schneidstoff

Indexable inserts – HSS cutting material

Inserti a fissaggio meccanico – Acciaio Super Rapido

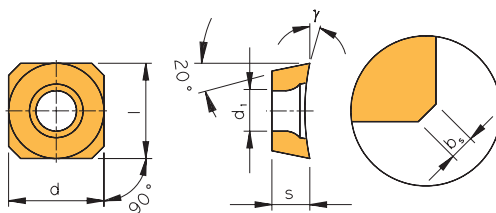

SEFT..



Bezeichnung Designation Articolo	l	d	s	d ₁	b _s	γ	Sorten / Grades / Gradi		beschichtet/ coated/ rivestito	
							HSS-TiN	HSS-TiAlN	HSS-TiN	HSS-TiAlN
SEFT 1204AFN	12,70	12,70	4,76	5,5	1,5x45° R0,8	12°	●	●	●	●

● Hauptanwendung Main application Applicazione principale	P	●
	M	●
○ Nebenanwendung Secondary application Applicazione secondaria	K	
	N	
	S	○
	H	

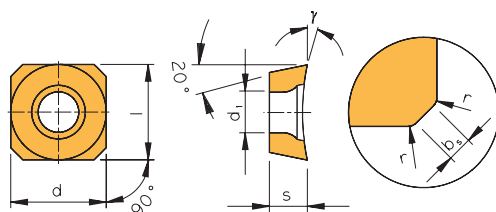

SEFX..



Bezeichnung Designation Articolo	l	d	s	d ₁	b _s	γ	Sorten / Grades / Gradi		beschichtet/ coated/ rivestito	
							HSS-TiN	HSS-TiAlN	HSS-TiN	HSS-TiAlN
SEFX 12T3AFN	13,27	13,27	3,97	3,4	1,5x45°	15°	●	●	●	●

● Hauptanwendung Main application Applicazione principale	P	●	●
	M	●	●
○ Nebenanwendung Secondary application Applicazione secondaria	K		
	N		
	S	○	○
	H		



6

Gewindefräsen

- Gewindearten
- Gewindefräsen – Übersicht
- Trägerwerkzeuge
- Wendschneidplatten

Thread milling

- *Insert preselection*
- *Thread Milling – Program overview*
- *HOLDERS*
- *Indexable inserts*

Fresatura per filettatura

- Tipi di filettature
- Fresatura per filettatura – Gamma prodotti
- Corpi fresa
- Inserti

252 – 254

255

256 – 258

260 – 269

6

Kennbuchstabe	Kurzbezeichnung Beispiel	Benennung	Norm	Zur Verfügung stehende Gewindeprofile
M	M 30	ISO-Metrisch- allg. Regelgewinde	DIN 13 T1	ISO-Metrisch
	M 20 x 1	allgemein mit großer Steigung	DIN 13 T2-11	
	DIN 6630 - M 64 x 4	Faßverschraubung, außen	DIN 6630	
	DIN 158 - M 30 x 2 keg	metrisch kegeliges Außengewinde	DIN 158	Auf Anfrage
G	G 1½	Zylindrisches Rohrgewinde, nicht im Gewinde dichtend, Innengewinde	DIN ISO 228 T1	Whitworth Rohrgewinde BSW, BSP
	G 1½ A	Außengewinde	DIN ISO 228 T1	
Rp	DIN 2999 - Rp ½ DIN 3858 - Rp ⅛	Zylindrisches Rohrgewinde, im Gewinde dichtend, Innengewinde	DIN 2999 T1 DIN 3858	Whitworth Rohrgewinde BSW, BSP
R	DIN 2999 - R ½ DIN 3858 - R ⅛ - 1	kegeliges Rohrgewinde, im Gewinde dichtend, Außengewinde	DIN 2999 T1 DIN 3858	Kegeliges Rohrgewinde BSPT
Tr	Tr 40 x 7	Metrisches ISO-Trapez- gewinde, allgemein	DIN 103 T1-8	Auf Anfrage
W	DIN 477 - W 21,8 x ⅛	Zylindrisches Whitworth-Gewinde	DIN 477 T1	Whitworth Rohrgewinde BSW, BSP
	DIN 477 - W 28,8 x ⅛ keg	Kegeliges Whitworth-Gewinde		Auf Anfrage
Pg	DIN 40430 - Pg 21	Stahlpanzerrohrgewinde	DIN 40430	Stahlpanzerrohrgewinde DIN 40430
UN	¼ - 20 UNC - 2A	Amerikanisches ISO-Zollgewinde Einheitsgewinde, grob		Amerikanisches ISO-Zollgewinde UN
	¼ - 28 UNF - 3A	Einheitsgewinde, fein		
UNJ	¼ - 28 UNJ - 3A	Luftfahrtgewinde		Luftfahrtgewinde UNJ
NPT	⅜ - 18 NPT	Kegeliges Rohrgewinde		Kegeliges Rohrgewinde NPT
NPTF	⅛ - 27 NPTF - 1	Kegeliges Feinrohrgewinde		Kegeliges Feinrohrgewinde NPTF
ACME	1¾ - 4 ACME - 2G	Amerikanisches Trapezgewinde		Auf Anfrage

HINWEIS: In der Tabelle sind die gängigsten Gewindearten aufgeführt. Weitere Gewindearten auf Anfrage.

Insert preselection

Identification	Short description Example	Description	DIN-Standard	Available threading insert
M	M 30	ISO-Metric thread	DIN 13 T1	ISO-Metric
	M 20 x 1	Coarse pitch	DIN 13 T2-11	
	DIN 6630 - M 64 x 4	barrel fittings external	DIN 6630	
	DIN 158 - M 30 x 2 keg	Metric tapered external thread	DIN 158	On request
G	G 1½	Cylindrical pipe thread, no sealing thread, internal thread	DIN ISO 228 T1	Whitworth pipe thread BSW, BSP
	G 1½ A	external thread	DIN ISO 228 T1	
Rp	DIN 2999 - Rp ½ DIN 3858 - Rp ⅛	Cylindrical pipe thread, sealing thread, internal thread	DIN 2999 T1 DIN 3858	Whitworth pipe thread BSW, BSP
R	DIN 2999 - R ½ DIN 3858 - R ⅛ - 1	Tapered pipe thread, sealing thread, external thread	DIN 2999 T1 DIN 3858	Tapered pipe thread BSPT
Tr	Tr 40 x 7	ISO-Trapezoidal thread, general	DIN 103 T1-8	On request
W	DIN 477 - W 21,8 x ⅛	Cylindrical Whitworth thread	DIN 477 T1	Whitworth pipe thread BSW, BSP
	DIN 477 - W 28,8 x ⅛ keg	Tapered Whitworth thread		On request
Pg	DIN 40430 - Pg 21	Pg-thread	DIN 40430	Pg-thread DIN 40430
UN	¼ - 20 UNC - 2A	American UN-thread coarse pitch		American UN-thread
	¼ - 28 UNF - 3A	fine pitch		
UNJ	¼ - 28 UNJ - 3A	Aerospace thread		Aerospace thread UNJ
NPT	⅜ - 18 NPT	Tapered pipe thread		Tapered pipe thread NPT
NPTF	⅛ - 27 NPTF - 1	Tapered fine pitch pipe thread		Tapered fine pipe thread NPTF
ACME	1¾ - 4 ACME - 2G	American trapezoidal thread		On request

REMARK: The above table shows the most common threads. Other threads are available on request.

Tipi di filettature

codice identificativo	Denominazione esempio	Descrizione	Norma	Tipologie di inserti disponibili
M	M 30	ISO-Metrica- filettatura normale	DIN 13 T1	ISO-Metrica
	M 20 x 1	Filettatura a passo Grosso	DIN 13 T2-11	
	DIN 6630 - M 64 x 4	Filettatura fusti, esterna	DIN 6630	
	DIN 158 - M 30 x 2 conica	Filettatura metrica Esterna conica	DIN 158	A richiesta
G	G 1½	Filettatura cilindrica per raccordi, filettatura a tenuta, filettatura interna	DIN ISO 228 T1	Filetto tubi Whitworth BSW, BSP
	G 1½ A	Esterna conica	DIN ISO 228 T1	
Rp	DIN 2999 - Rp ½ DIN 3858 - Rp ⅛	Filettatura cilindrica per raccordi, filetto a tenuta, filettatura interna	DIN 2999 T1 DIN 3858	Filetto tubi Whitworth BSW, BSP
R	DIN 2999 - R ½ DIN 3858 - R ⅛ - 1	Filettatura conica per raccordi, filetto a tenuta, Esterna conica	DIN 2999 T1 DIN 3858	Filetto conico tubi BSPT
Tr	Tr 40 x 7	Filettatura Metrica Trapezoidale, normale	DIN 103 T1-8	A richiesta
W	DIN 477 - W 21,8 x ⅛	Filettatura cilindrica Whitworth	DIN 477 T1	Filetto tubi Whitworth BSW, BSP
	DIN 477 - W 28,8 x ⅛ conica	Filettatura conica Whitworth		A richiesta
Pg	DIN 40430 - Pg 21	Filettatura PG	DIN 40430	Filettatura pg DIN 40430
UN	¼ - 20 UNC - 2A	Filettatura a norma americana UN, filettatura normale, passo grosso		Filettatura a norma standard americana UN
	¼ - 28 UNF - 3A	Filettatura a norma americana UN, filettatura normale, passo grosso		
UNJ	¼ - 28 UNJ - 3A	Filettatura aeronautica		Filettatura aeronautica UNJ
NPT	⅜ - 18 NPT	Filetto conico tubi		Filetto conico tubi NPT
NPTF	⅛ - 27 NPTF - 1	Filettatura tubi conica a passo fine		Filettatura tubi conica a passo fine NPTF
ACME	1¾ -4 ACME - 2G	Filettatura a norma americana ACME trapezoidale		A richiesta

NOTA: La tabella riporta i più comuni filetti utilizzati. Altre tipologie disponibili a richiesta.

Gewindefräsen – Übersicht

Thread Milling – Program overview

Fresatura per filettatura – Gamma prodotti

Wendeschneidplatten

Indexable inserts

Inserti

Seite / Page / Pagina

Klemmhalter

Tool holders

Corpi fresa

Seite / Page / Pagina

Metrisch

Metric

Metrica

ISO

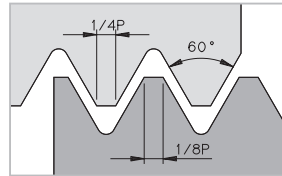

262 – 263

256 – 257

Amerikanisches ISO-Zollgewinde

American thread

Filettatura norme americane

UN

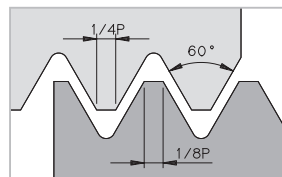

264 – 265

257

Whitworth Rohrgewinde

Whitworth pipe thread

Filettatura tubi Whitworth

BSW, BSP

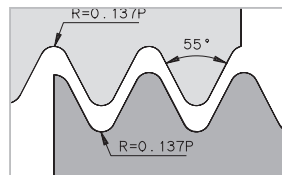

266

257

Kegeliges Rohrgewinde

Tapered pipe thread

Filettatura conica tubi

BSPT

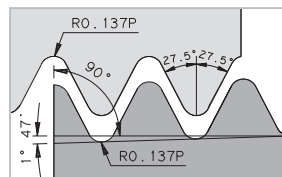

267

258

Stahlpanzerrohrgewinde

PG-thread

Filettatura PG

DIN 40430

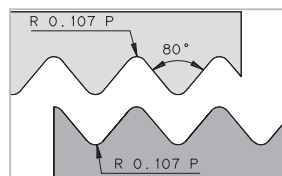

268

257

Kegeliges Rohrgewinde

Tapered pipe thread

Filettatura conica tubi

NPT

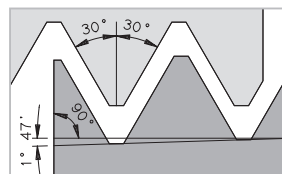

269

258

Gewindefräser für kleine Bohrungsdurchmesser ab 9,5 mm

Thread milling cutter for small bore diameter down to 9.5 mm

Fresa a filettare per diametro di foro piccolo a partire da 9,5 mm

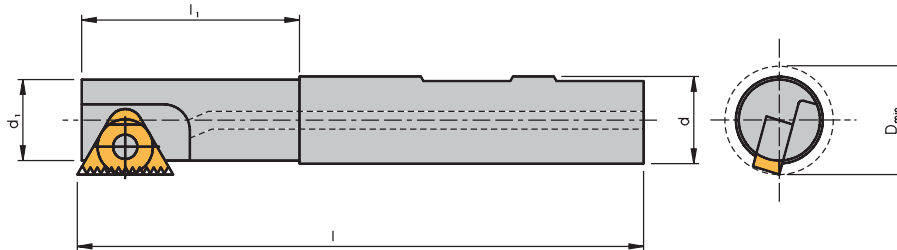

Halter / Holder / Utensile

	Bezeichnung Designation Articolo	l	l ₁	d	d ₁	D _{min}
10,4	TMMC 12-6,0	69	12	12	6,8	9
10,4	TMMC 20-6,0	84	17	20	6,8	9

ACHTUNG: Beim Fräsen von Innengewinden – aufgrund der Profilverzerrung – kleinsten Bohrungsdurchmesser beachten. Seite 270.

ATTENTION: If producing an internal thread, attention has to be paid to the minimum bore diameters for thread milling. Page 270.

ATTENZIONE: In caso di fresatura di un filetto interno – in base alla deformazione del profilo – deve essere posta attenzione al diametro di foro minimo. Pag. 270.

Ersatzteile / Spare parts / Ricambi

	Klemmschraube Clamping screw Vite di bloccaggio	Schlüssel Key Chiave
10,4	SN7T	KS 5151

Standard-Gewindefräser

Standard thread milling cutter

Fresa a filettare standard

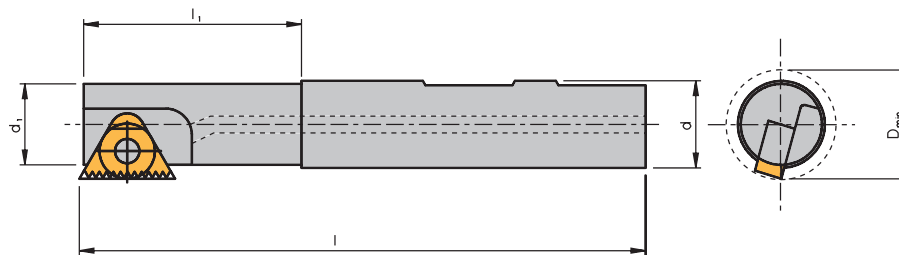

Halter / Holder / Utensile

	Bezeichnung Designation Articolo	l	l ₁	d	d _i	D _{min}
11	TMC 12-2	70	12	12	8,9	11,5
11	TMC 20-2	85	20	20	8,9	11,5
16	TMC 16-3	90	22	16	13,6	17,0
16	TMC 20-3	95	43	20	16,6	20,0
27	TMC 25-5	110	52	25	24,0	30,0
27	TMC 32-5	120	58	32	31,0	37,0

ACHTUNG: Beim Fräsen von Innengewinden – aufgrund der Profilverzerrung – kleinsten Bohrungsdurchmesser beachten. Seite 270.

ATTENTION: If producing an internal thread, attention has to be paid to the minimum bore diameters for thread milling. Page 270.

ATTENZIONE: In caso di fresatura di un filetto interno – in base alla deformazione del profilo – deve essere posta attenzione al diametro di foro minimo. Pag. 270.

Ersatzteile / Spare parts / Ricambi

	Klemmschraube Clamping screw Vite di bloccaggio	Schlüssel Key Chiave
11	SN2T	KS 1751
16	SN3T	KS 2510
27	SN5TM	KS 2525

Gewindefräser für kegliche Gewinde

Thread milling cutter for tapered threads

Fresa a filettare per filetti conici

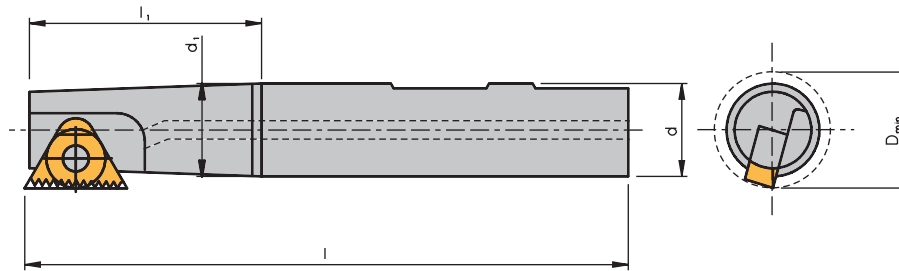

Halter / Holder / Utensile

	Bezeichnung Designation Articolo	l	l ₁	d	d ₁	D _{min}
16	TMNC 16-3L	80	22	16	12,5	15,5
16	TMNC 16-3R	80	22	16	12,5	15,5
16	TMNC 20-3R	85	23	20	15,0	19,0

ACHTUNG: Beim Fräsen von Innengewinden – aufgrund der Profilverzerrung – kleinsten Bohrungsdurchmesser beachten. Seite 270.

Linke Wendeschneidplatten sind mit „L“ gekennzeichnet und benötigen einen linken Gewindefräser.

ATTENTION: If producing an internal thread, attention has to be paid to the minimum bore diameters for thread milling. Page 270.

Left-hand indexable inserts are marked with "L" and require a left-hand milling cutter.

ATTENZIONE: In caso di fresatura di un filetto interno – in base alla deformazione del profilo – deve essere posta attenzione al diametro di foro minimo. Pag. 270.

Gli inserti "sinistri" sono marcati con "L" e necessitano di una fresa a filettare sinistra.

Ersatzteile / Spare parts / Ricambi

	Klemmschraube Clamping screw Vite di bloccaggio	Schlüssel Key Chiave
16	SN3T	KS 2510

Rundum überzeugend: ARNO-Gewindefräser aus Vollhartmetall für die Bearbeitung von Stahl, Aluminium und NE-Metallen.

*Solid carbide thread mills for steel, aluminium and
none ferrous materials.*

Frese a filettare per tutti i tipi di filettature e
per lavorazione di acciai e ghise.



ARNO® VOLLHARTMETALL GEWINDEFÄSER

TiAlN beschichtete Gewindefräser aus Feinstkorn-Hartmetall bieten Ihnen eine optimale, gleichmäßige Gewindequalität sowie eine hohe Verschleißfestigkeit.

Fine grain solid carbide cutters with TiAlN coating, some with through tool coolant and chamfering edge.

Frese a filettare in metallo duro integrale rivestite per lavorare Acciaio, ghisa, Acciaio inossidabile, leghe esotiche o refrattarie e acciai temprati fino a 50 HRC.

Weitere Vollhartmetall-Fräser finden Sie im aktuellen Tiefstpreiskatalog oder unter:

You will find more solid carbide cutters in our "Special Price" catalogue:

La gamma completa di frese in MDI è disponibile sul catalogo dedicato "Catalogo Promozione" oppure visitando il sito:

www.arno.de

Hartmetall beschichtet / Carbide coated / Metallo duro rivestito

AL100

TiAlN-beschichtete Hartmetallsorte zur Bearbeitung von Stahlwerkstoffen, rostfreiem Stahl, Gusswerkstoffen und exotischen Materialien wie Hastelloy, Waspaloy und Inconel. Auch für die Hartzerspanung geeignet.

TiAlN coated carbide grade for machining steel, stainless steel, cast and exotic materials such as Hastelloy, Waspaloy and Inconel. Grade can also be used for hard machining.

Qualità rivestita TiAlN per la lavorazione di acciaio, acciaio inossidabile, acciaio da fusione e materiali esotici quali Hastelloy, Waspaloy ed Inconel. Qualità idonea anche per materiali duri.

AM15C

TiN-beschichtete Feinkorn-Hartmetallsorte mit sehr hoher Zähigkeit. Bearbeitung von Stahl, rostfreiem Stahl, Nickelbasislegierungen, Aluminium und Grauguss. Besonders geeignet für exotische Werkstoffe und säurebeständige Stähle.

TiN coated sub micron grade with high toughness. Machining steel, stainless steel, nickel based alloys, aluminum and cast iron. Specially suitable for exotic materials and acid resistant materials.

Qualità rivestita TiN su base Sub-micrograna con elevata tenacità. Per la lavorazione di acciaio, acciaio inossidabile, leghe a base Nichel, alluminio e ghisa. Specialmente valida per lavorazioni di materiali esotici e leghe anti-corrosive.

Hartmetall unbeschichtet / Carbide uncoated / Metallo duro non rivestito

AK20

Bearbeitung von NE-Metallen und Grauguss bei kleinen Schnittgeschwindigkeiten. Außerdem geeignet für hochwarmfeste Werkstoffe. Gute Kantenschärfe.

Machining of non-ferrous materials and grey cast iron at normal cutting speeds. Also suitable for heat-resistant materials. Good cutting edge stability.

Qualità per la lavorazione di materiali non ferrosi e ghisa grigia a normali velocità di taglio. Idonea anche per leghe refrattarie. Buona stabilità del tagliente.

ISO	Hartmetall beschichtet Carbide coated Metallo duro rivestito	Hartmetall unbeschichtet Carbide uncoated Metallo duro non rivestito	Schneidstoff Cutting material Materiale da taglio	Anwendung Application Parametri
P Stahl, Stahlguss, langspanender Temperguss <i>Steel, cast steel, malleable iron</i> Acciaio, acciaio da fusione, ghisa malleabile da truciolo lungo	10			
	20	AL100 AM15C		
	30			Zähigkeit Toughness / Tenacità
	40			Verschleißbeständigkeit / Wear resistance / Resistenza all'usura
	50			Vorschub Feed rate / Avanzamento
M Rostfreier Stahl, Stahlguss, Manganstahl, Automatenstahl <i>Stainless steel, cast steel, manganese steel, free cutting steel</i> Acciaio Inossidabile, Acciaio da Fusione, Acciaio al Manganese, Acciaio Automatico	10			
	20	AL100 AM15C		
	30			Zähigkeit Toughness / Tenacità
	40			Verschleißbeständigkeit / Wear resistance / Resistenza all'usura
	50			Vorschub Feed rate / Avanzamento
K Grauguss, Kokillenhartguss, kurzspanender Temperguss <i>Grey cast iron, chilled hard cast iron, short chipping malleable iron</i> Ghisa grigia, ghisa sferoidale, ghisa malleabile a truciolo corto	10			
	20	AL100 AM15C		
	30		AK20	
	40			Zähigkeit Toughness / Tenacità
	50			Verschleißbeständigkeit / Wear resistance / Resistenza all'usura
N Aluminium und Al-Legierungen, nichtmetallische Werkstoffe <i>Aluminum and Al-alloys, non-ferrous materials</i> Alluminio e sue leghe, materiali non ferrosi o non metallici	10			
	20	AM7C AM15C		
	30		AK20	
	40			Zähigkeit Toughness / Tenacità
	50			Verschleißbeständigkeit / Wear resistance / Resistenza all'usura
S Warmfeste Legierungen, Titanlegierungen <i>High temperature resistant alloys, titanium alloys</i> Leghe refrattarie, leghe esotiche, leghe di titanio	10			
	20	AL100		
	30		AK20	
	40			Zähigkeit Toughness / Tenacità
	50			Verschleißbeständigkeit / Wear resistance / Resistenza all'usura
H Gehärteter Stahl, Hartguss <i>Hardened steel, hard cast iron</i> Acciaio temprato, ghisa temprata	10			
	20	AL100 AM15C		
	30			Zähigkeit Toughness / Tenacità
	40			Verschleißbeständigkeit / Wear resistance / Resistenza all'usura
	50			Vorschub Feed rate / Avanzamento

Hauptanwendungsbereich / Main application area / Applicazione principale

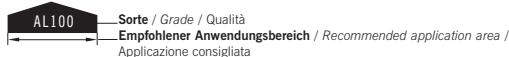

Nebenanwendungsbereich / Secondary application area / Applicazione secondaria



Außengewinde

External threading
Filettatura esterna

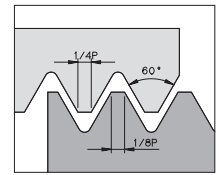
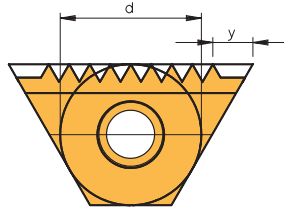

Teilung Pitch Passo [mm]	Bezeichnung Designation Articolo	d	y	z	Sorten / Grades / Qualità			Klemmhalter Tool holder Corpo fresa	
					beschichtet coated rivestito		unbeschichtet uncoated non rivestito		
					AM15C	AL100	AK20		
11	0,50	11E-ISO0,50TMF	6,35	0,8	20			●	TMC...-2
11	0,75	11E-ISO0,75TM	6,35	0,6	14		●		TMC...-2
11	1,00	11E-ISO1,00TM	6,35	1,0	10		●		TMC...-2
11	1,25	11E-ISO1,25TM	6,35	1,1	8	●	●		TMC...-2
11	1,50	11E-ISO1,50TM	6,35	1,0	6	●		●	TMC...-2
16	0,75	16E-ISO0,75TM	9,52	1,1	20	●		●	TMC...-3
16	1,00	16E-ISO1,00TM	9,52	1,3	14			●	TMC...-3
16	1,25	16E-ISO1,25TM	9,52	1,4	12	●		●	TMC...-3
16	1,50	16E-ISO1,50TM	9,52	1,5	10	●	●	●	TMC...-3
16	1,75	16E-ISO1,75TM	9,52	2,1	8		●	●	TMC...-3
16	2,00	16E-ISO2,00TM	9,52	2,3	7		●	●	TMC...-3
27	1,00	27E-ISO1,00TM	15,87	1,3	26			●	TMC...-5
27	1,25	27E-ISO1,25TM	15,87	1,4	20			●	TMC...-5
27	1,50	27E-ISO1,50TM	15,87	1,8	17			●	TMC...-5
27	1,75	27E-ISO1,75TM	15,87	2,4	14	●		●	TMC...-5
27	2,00	27E-ISO2,00TM	15,87	2,8	12	●		●	TMC...-5
27	2,50	27E-ISO2,50TM	15,87	2,5	10	●		●	TMC...-5
27	3,00	27E-ISO3,00TM	15,87	3,3	8	●		●	TMC...-5
27	3,50	27E-ISO3,50TM	15,87	3,3	7	●		●	TMC...-5
27	4,00	27E-ISO4,00TM	15,87	3,8	6	●		●	TMC...-5
27	4,50	27E-ISO4,50TM	15,87	4,7	5			●	TMC...-5

Hinweis: Wendeschneidplatten sind doppelseitig einsetzbar.
Remark: Indexable inserts are double-sided.
Nota: Gli inserti sono a due lati.

P	○	●
M	●	●
K		○
N		●
S		○
H		

● Hauptanwendung
Main application
Applicazione principale

○ Nebenanwendung
Secondary application
Applicazione secondaria

Innengewinde

Internal threading
Filettatura interna

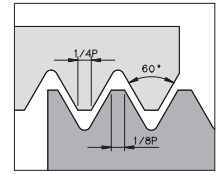
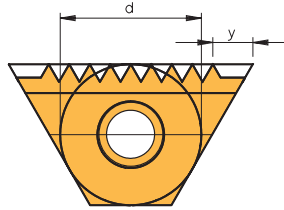

Teilung Pitch Passo [mm]	Bezeichnung Designation Articolo	d	y	z	Sorten / Grades / Qualità			Klemmhalter Tool holder Corpo fresa
					beschichtet coated rivestito		unbeschichtet uncoated non rivestito	
					AM15C	AL100	AK20	
10,4	0,50	10,4I-ISO0,50TM	6,00	0,4	20		●	TMMC...-6,0
10,4	0,75	10,4I-ISO0,75TM	6,00	0,7	13		●	TMMC...-6,0
10,4	1,00	10,4I-ISO1,00TM	6,00	1,2	9		●	TMMC...-6,0
11	0,50	11I-ISO0,50TM	6,35	0,8	20		●	TMC...-2
11	0,75	11I-ISO0,75TM	6,35	0,6	14		●	TMC...-2
11	1,00	11I-ISO1,00TM	6,35	1,0	10		●	TMC...-2
11	1,25	11I-ISO1,25TM	6,35	1,1	7		●	TMC...-2
11	1,50	11I-ISO1,50TM	6,35	1,0	7		●	TMC...-2
16	0,50	16I-ISO0,50TM	9,52	1,0	30	●		TMC...-3
16	0,75	16I-ISO0,75TM	9,52	1,1	20	●		TMC...-3
16	1,00	16I-ISO1,00TM	9,52	1,8	15		●	TMC...-3
16	1,25	16I-ISO1,25TM	9,52	1,4	12	●		TMC...-3
16	1,50	16I-ISO1,50TM	9,52	1,5	10	●		TMC...-3
16	1,75	16I-ISO1,75TM	9,52	2,1	8	●		TMC...-3
16	2,00	16I-ISO2,00TM	9,52	2,3	7		●	TMC...-3
27	1,00	27I-ISO1,00TM	15,87	1,3	26		●	TMC...-5
27	1,25	27I-ISO1,25TM	15,87	1,4	20		●	TMC...-5
27	1,50	27I-ISO1,50TM	15,87	1,8	17	●		TMC...-5
27	1,75	27I-ISO1,75TM	15,87	2,4	14	●		TMC...-5
27	2,00	27I-ISO2,00TM	15,87	2,8	12		●	TMC...-5
27	2,50	27I-ISO2,50TM	15,87	2,5	10	●		TMC...-5
27	3,00	27I-ISO3,00TM	15,87	3,3	8		●	TMC...-5
27	3,50	27I-ISO3,50TM	15,87	3,3	7	●		TMC...-5
27	4,00	27I-ISO4,00TM	15,87	3,8	6		●	TMC...-5
27	4,50	27I-ISO4,50TM	15,87	4,7	5		●	TMC...-5

Hinweis: Wendschneidplatten sind doppelseitig einsetzbar, außer Wendschneidplatten mit l=10,4 mm – diese sind einseitig einsetzbar.
Remark: Indexable inserts are double-sided, except indexable inserts with l=10.4 mm are single sided.
Nota: Gli inserti sono a due lati, eccetto gli inserti con l=10.4 mm sono ad un solo lato.

P	○	●
M	●	●
K		○
N		●
S		○
H		

● Hauptanwendung
Main application
Applicazione principale
○ Nebenanwendung
Secondary application
Applicazione secondaria

Außengewinde

External threading

Filettatura esterna

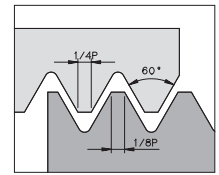
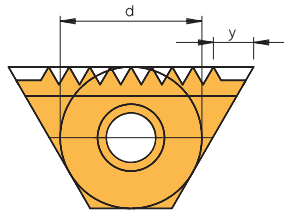

Teilung Pitch Passo [G/Inch]	Bezeichnung Designation Articolo	d	y	z	Sorten / Grades / Qualità		Klemmhalter Tool holder Corpo fresa	
					beschichtet coated rivestito AM15C	unbeschichtet uncoated non rivestito AK20		
16	28	16E-UN28TM	9,52	1,1	16		●	TMC...-3
16	24	16E-UN24TM	9,52	1,4	14		●	TMC...-3
16	20	16E-UN20TM	9,52	1,9	11	●	●	TMC...-3
16	18	16E-UN18TM	9,52	1,9	10	●	●	TMC...-3
16	16	16E-UN16TM	9,52	1,9	9	●	●	TMC...-3
16	14	16E-UN14TM	9,52	1,9	8	●	●	TMC...-3
16	13	16E-UN13TM	9,52	1,9	7		●	TMC...-3
16	12	16E-UN12TM	9,52	1,9	7	●	●	TMC...-3
27	24	27E-UN24TM	15,87	1,6	24		●	TMC...-5
27	20	27E-UN20TM	15,87	1,9	20		●	TMC...-5
27	18	27E-UN18TM	15,87	1,8	18		●	TMC...-5
27	16	27E-UN16TM	15,87	1,8	16	●	●	TMC...-5
27	14	27E-UN14TM	15,87	2,0	14		●	TMC...-5
27	13	27E-UN13TM	15,87	2,1	13		●	TMC...-5
27	12	27E-UN12TM	15,87	2,1	12	●	●	TMC...-5
27	11	27E-UN11TM	15,87	2,3	11		●	TMC...-5
27	10	27E-UN10TM	15,87	2,3	9	●	●	TMC...-5
27	9	27E-UN9TM	15,87	3,9	8		●	TMC...-5
27	8	27E-UN8TM	15,87	4,2	7	●	●	TMC...-5
27	7	27E-UN7TM	15,87	2,9	6		●	TMC...-5
27	6	27E-UN6TM	15,87	3,2	5		●	TMC...-5

Hinweis: Wendschneidplatten sind doppelseitig einsetzbar.
 Remark: Indexable inserts are double-sided.
 Nota: Gli inserti sono a due lati.

P	○
M	●
K	
N	●
S	
H	

● Hauptanwendung
Main application
Applicazione principale

○ Nebenanwendung
Secondary application
Applicazione secondaria

Innengewinde

Internal threading

Filettatura interna

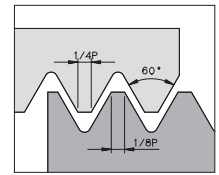
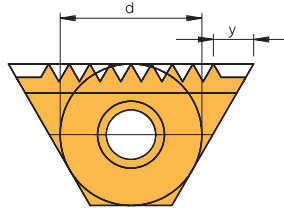

Teilung Pitch Passo [G/Inch]	Bezeichnung Designation Articolo	d	y	z	Sorten / Grades / Qualità		Klemmhalter Tool holder Corpo fresa	
					beschichtet coated rivestito AM15C	unbeschichtet uncoated non rivestito AK20		
11	28	111-UN28TM	6,35	1,0	11		●	TMC...-2
11	24	111-UN24TM	6,35	1,3	9		●	TMC...-2
11	20	111-UN20TM	6,35	1,7	8		●	TMC...-2
11	16	111-UN16TM	6,35	1,9	6		●	TMC...-2
16	32	161-UN32TM	9,52	0,7	19		●	TMC...-3
16	28	161-UN28TM	9,52	1,4	16		●	TMC...-3
16	24	161-UN24TM	9,52	1,4	14	●	●	TMC...-3
16	20	161-UN20TM	9,52	1,9	11	●	●	TMC...-3
16	18	161-UN18TM	9,52	1,9	10		●	TMC...-3
16	16	161-UN16TM	9,52	1,9	9	●	●	TMC...-3
16	14	161-UN14TM	9,52	1,9	8		●	TMC...-3
16	13	161-UN13TM	9,52	1,9	7		●	TMC...-3
16	12	161-UN12TM	9,52	1,9	7	●	●	TMC...-3
27	24	271-UN24TM	15,87	1,6	24		●	TMC...-5
27	20	271-UN20TM	15,87	1,9	20		●	TMC...-5
27	18	271-UN18TM	15,87	1,8	18		●	TMC...-5
27	16	271-UN16TM	15,87	1,8	16		●	TMC...-5
27	14	271-UN14TM	15,87	2,0	14		●	TMC...-5
27	13	271-UN13TM	15,87	2,1	13		●	TMC...-5
27	12	271-UN12TM	15,87	2,1	12		●	TMC...-5
27	11	271-UN11TM	15,87	2,3	11	●	●	TMC...-5
27	10	271-UN10TM	15,87	3,6	10	●	●	TMC...-5
27	9	271-UN9TM	15,87	3,9	8		●	TMC...-5
27	8	271-UN8TM	15,87	4,2	7	●	●	TMC...-5
27	7	271-UN7TM	15,87	4,8	7		●	TMC...-5
27	6	271-UN6TM	15,87	4,8	6		●	TMC...-5

Hinweis: Wendeschneidplatten sind doppelseitig einsetzbar.
Remark: Indexable inserts are double-sided.
Nota: Gli inserti sono a due lati.

P	○
M	●
K	
N	●
S	
H	

● Hauptanwendung
Main application
Applicazione principale

○ Nebenanwendung
Secondary application
Applicazione secondaria

Außen- und Innengewinde

External and internal threading
Filettatura interna ed esterna

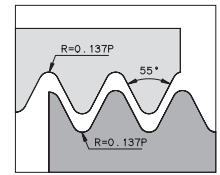
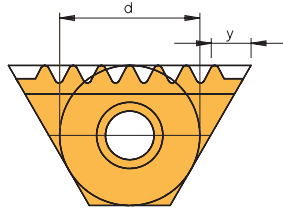

Teilung Pitch Passo [G/Inch]	Bezeichnung Designation Articolo	d	y	z	Sorten / Grades / Qualità		Klemmhalter Tool holder Corpo fresa		
					beschichtet coated rivestito	unbeschichtet uncoated non rivestito			
					AM15C	AL100	AK20		
11	14	11EI-W14TM	6,35	1,9	5		●	TMC...-2	
16	24	16EI-W24TM	9,52	1,4	14			●	TMC...-3
16	20	16EI-W20TM	9,52	1,9	11			●	TMC...-3
16	19	16EI-W19TM	9,52	1,6	11	●		●	TMC...-3
16	18	16EI-W18TM	9,52	1,9	10			●	TMC...-3
16	16	16EI-W16TM	9,52	1,9	9			●	TMC...-3
16	14	16EI-W14TM	9,52	1,9	8			●	TMC...-3
16	12	16EI-W12TM	9,52	1,9	7	●		●	TMC...-3
16	11	16EI-W11TM	9,52	2,5	6		●	●	TMC...-3
27	16	27EI-W16TM	15,87	1,8	16			●	TMC...-5
27	14	27EI-W14TM	15,87	2,0	14	●		●	TMC...-5
27	12	27EI-W12TM	15,87	3,2	11	●		●	TMC...-5
27	11	27EI-W11TM	15,87	3,4	10			●	TMC...-5
27	10	27EI-W10TM	15,87	2,3	10			●	TMC...-5
27	9	27EI-W9TM	15,87	3,9	8			●	TMC...-5
27	8	27EI-W8TM	15,87	4,2	7			●	TMC...-5
27	7	27EI-W7TM	15,87	4,7	6			●	TMC...-5

Hinweis: Wendeschneidplatten sind doppelseitig einsetzbar.
Remark: Indexable inserts are double-sided.
Nota: Gli inserti sono a due lati.

	AM15C	AL100	AK20
P	○	●	
M	●	●	
K		○	●
N			●
S		○	
H			

● Hauptanwendung
Main application
Applicazione principale
○ Nebenanwendung
Secondary application
Applicazione secondaria

Außen- und Innengewinde

External and internal threading
Filettatura interna ed esterna

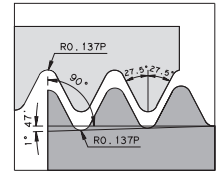
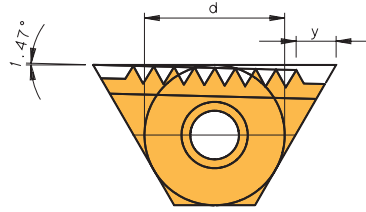

Teilung Pitch Passo [G/Inch]	Bezeichnung Designation Articolo	d	y	z	Nenn-Rohr-Ø Nominal pipe-Ø D min foro	Sorten / Grades / Qualità		Klemmhalter Tool holder Corpo fresa
						beschichtet coated rivestito AM15C	unbeschichtet uncoated non rivestito AK20	
16	14 16EI-BSPT14TM	9,52	1,9	8	1/2", 3/4"	●	●	TMNC 16-3 R/L
16	11 16EI-BSPT11TM	9,52	2,5	6	1", 1 1/4"	●	●	TMNC 20-3 R/L

Hinweis: Wendeschneidplatten sind doppelseitig einsetzbar.
Remark: Indexable inserts are double-sided.
Nota: Gli inserti sono a due lati.

P	○
M	●
K	●
N	●
S	
H	

● Hauptanwendung
Main application
Applicazione principale

○ Nebenanwendung
Secondary application
Applicazione secondaria

Außen- und Innengewinde

External and internal threading

Filettatura interna ed esterna

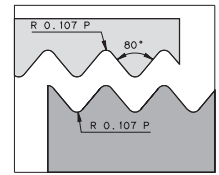
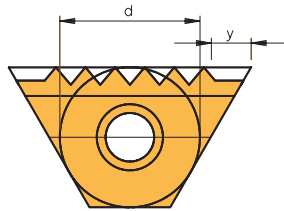

Teilung Pitch Passo [G/Inch]	Bezeichnung Designation Articolo	d	y	z	Sorten / Grades / Qualità		Klemmhalter Tool holder Corpo fresa
					beschichtet coated rivestito AM15C	unbeschichtet uncoated non rivestito AK20	
16	20 16EI-PG20TM	9,52	1,65	11	●	●	TMC...-3
16	18 16EI-PG18TM	9,52	1,65	10	●	●	TMC...-3
16	16 16EI-PG16TM	9,52	1,64	9	●	●	TMC...-3

Hinweis: Wendschneidplatten sind doppelseitig einsetzbar.
Remark: Indexable inserts are double-sided.
Nota: Gli inserti sono a due lati.

Sorten / Grades / Qualità	beschichtet coated rivestito	unbeschichtet uncoated non rivestito
P	○	
M	●	
K		●
N		●
S		
H		

● Hauptanwendung
Main application
Applicazione principale

○ Nebenanwendung
Secondary application
Applicazione secondaria

Außen- und Innengewinde

External and internal threading
Filettatura interna ed esterna

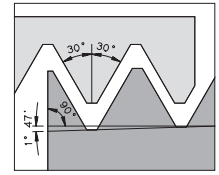
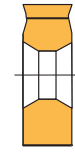
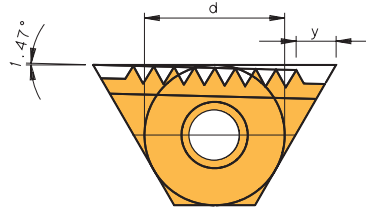

	Teilung Pitch Passo [G/Inch]	Bezeichnung Designation Articolo	d	y	z	Nenn-Rohr-Ø Nominal pipe-Ø D min foro	Sorten / Grades / Qualità		Klemmhalter Tool holder Corpo fresa
							beschichtet coated rivestito AM15C	unbeschichtet uncoated non rivestito AK20	
16	14,0	16EI-NPT14TM	9,52	1,0	8	1/2"	●	●	TMNC 16-3 R/L
16	11,5	16EI-NPT11,5TM	9,52	2,3	6	1", 1 1/4"	●	●	TMNC 16-3 R/L

Hinweis: Wendeschneidplatten sind doppelseitig einsetzbar.
Remark: Indexable inserts are double-sided.
Nota: Gli inserti sono a due lati.

P	○
M	●
K	●
N	●
S	
H	

● Hauptanwendung
Main application
Applicazione principale

○ Nebenanwendung
Secondary application
Applicazione secondaria

Kleinster Bohrungsdurchmesser / Minimal bore diameter / Diametro di foro minimo

Um beim Fräsen von Innengewinde im Rahmen der erlaubten Profilverzerrung zu bleiben, gibt die nachfolgende Tabelle den kleinsten Bohrungsdurchmesser (Funktion von Steigung und Gewindefräser) an.

Minimum bore diameters for thread milling (if milling cutter is used within this diameter range accurate thread profiles are produced).

In caso di fresatura di un filetto interno per rimanere nei limiti di deformazione consentiti, la seguente tabella indica il diametro minimo di foro (funzione di pendenza/ascesa e fresa filettata).

Steigung / Pitch / Passo [mm] [G/Inch]	Bezeichnung Designation Articolo D _{min} [mm]	0,50	0,60	0,70	0,75	0,80	1,00	1,25	1,50	2,00	2,50	3,00	3,50	4,00	4,50	6,00
		48	44	36		32	24	20	16	12	10	8	7	6		
		Kleinster Bohrungsdurchmesser Minimal bore diameter Diametro di foro minimo [mm]														
		9,5			10,0		10,7	11,4	12,0							
		12,0			12,5		13,2	13,9	14,5							
		16,0			16,5		17,2	17,9	18,5	19,5						
		17,6			18,2		19,0	19,6	20,0	21,0						
		19,7			20,4		21,0	21,6	22,0	23,0						
		20,7			21,4		22,0	22,6	23,0	24,0						
		30,7			31,4		32,0	32,8	33,5	34,6	36,6	39,0	42,0	45,0	48,0	
		38,0			38,6		39,5	40,4	41,0	42,0	44,0	46,5	49,0	52,0	55,5	

Beispiel:

Fräsen Innengewinde ISO-Metrisch mit Wendeschneidplatte 16I-ISO1, 25TM, Bohrungsdurchmesser = 21,5 mm.

Zwei Klemmhalter stehen zur Verfügung:

TMC 16-3 D_{min} = 17 mm

Lt. Tabelle kleinster Bohrungsdurchmesser 19,6 mm, d. h. Gewindefräser ist zu verwenden.

TMC 20-3 D_{min} = 20 mm

Lt. Tabelle kleinster Bohrungsdurchmesser 22,6 mm, d. h. Gewindefräser kann nicht verwendet werden. (Durchmesser zu groß).

Example:

Milling of an internal thread ISO-metric with indexable insert 16I-ISO1, 25TM, Bore diameter = 21.5 mm.

Two milling cutters are available:

TMC 16-3 D_{min} = 17 mm

According to above table minimum bore diameter 19.6 mm, milling cutter can be used.

TMC 20-3 D_{min} = 20 mm

According to above table minimum bore diameter 22.6 mm, milling cutter can't be used. (Diameter too big).

Esempio:

Filetto interno della fresa ISO-metrico con inserti 16I-ISO1, 25TM, diametro del foro 21,5 mm.

Sono disponibili 2 frese:

TMC 16-3 D_{min} = 17 mm

In riferimento alla tabella qui sopra il diametro di foro minimo è 19,6 mm, significa che la fresa filettata può essere usata.

TMC 20-3 D_{min} = 20 mm

In riferimento alla tabella qui sopra il diametro di foro minimo è 22,6 mm, significa che la fresa filettata non può essere usata. (Il diametro è troppo grande).

ARNO-Toleranzklassen / ARNO-tolerance / ARNO Classe tolleranza

Normbezeichnung Standard designation Identificazione standard	Norm DIN-Standard Norma	Toleranzklasse Tolerance Classe tolleranza
ISO	R262 (DIN 13)	6g / 6H
UN	ANSI B 1.1.74	2A / 2B
UNJ	MIL - S - 8879A	3A / 3B
BSW, BSP	B.S. 84: 1956, DIN 259, ISO 228/A: 1982	Medium Class A
BSPT	B.S. 21: 1985	Standard BSPT
NPT	USAS B2.1: 1968	Standard NPT
NPTF	ANSI B 1.20.3 - 1976	Standard
PG	DIN 40430	Standard
TR	DIN 103	7e / 7H
ACME	ANSI B1/5: 1988	3G

INFORMATIONEN

INFORMATION

INFORMAZIONI

Informationen

- Vergleichstabellen
- Verschleiß und Abhilfe
- Anwendungshinweise
- Empfohlene Schnittwerte

Information

- *Material – Cross Reference*
- *Insert Wear and Solutions*
- *Application Reference*
- *Recommended Cutting Data*

Informazioni

- Tabelle comparative
- Problemi e suggerimenti
- Note Tecniche
- Parametri di taglio

272 – 276

277 – 279

280 – 288

290 – 316



Werkstoff-Vergleichstabelle

Material – comparison table

Tavola comparativa dei materiali

ISO	W-Nr.	Deutschland	Belgien	Frankreich	Großbritannien	Italien
		Germany Germania	Belgium Belgio	France Francia	Great Britain Gran Bretagna	Italy Italia
		DIN	NBN	AFNOR	B.S.	UNI
Bau- und Konstruktionsstähle / Structural and constructional steels / Acciai da costruzione						
P	1.0401	C15	–	AF37C12	080A15	C15
	1.0402	C22	C25-1	AF42C20	055M15	C20
	1.0501	C35	C35-1	1C35	080A32	C35
	1.0503	C45	C45-1	1C45	060A47	C45
	1.0535	C55	C55-1	1C55	070M55	C55
	1.0601	C60	C60-1	1C60	060A62	C60
	1.0715	9SMn28	–	S250	230M07	CF9SMn28
	1.0718	9SMnPb28	–	S250Pb	–	CF9SMnPb28
	1.0722	10SPb20	–	10PbF2	–	CF10SPb20
	1.0726	10SPb2035S20	–	35MF6	212M36	–
	1.0736	9SMn36	–	S300	–	CF9SMn36
	1.0737	9SMnPb36	–	S300Pb	–	CF9SMnPb36
	1.1141	Ck15	C16-2	XC12	040A15	C15
	1.1157	40Mn4	–	35M5	150M36	–
	1.1158	C25E	C25-2	2C25	–	C25
	1-1167	36Mn5	–	35M5	150M36	–
	1.1170	28Mn6	28Mn6	20M5	–	C28Mn
	1.1183	Cf35	C36	XC38H1TS	080A35	C36
	1.1191	C45E	C45-2	2C45	080M46	C45
	1.1203	C55E	C55-2	2C55	060A57	C55
	1.1213	Cf53	C53	XC48H1TS	070M55	C53
	1.1221	C60E	C60-2	2C60	060A62	C60
	1.1274	Ck101	–	XC100	–	C100
	1.3401	X120Mn12	–	Z120M12	–	GX120Mn12
	1.3505	100Cr6	–	100C6	2S135	100Cr6
	1.5415	16Mo3	16Mo3	15D3	1503-243B	16Mo3
	1.5423	16Mo5	16Mo5	–	–	16Mo5KG
	1.5622	14Ni6	18Ni6	16N6	–	14Ni6KG
	1.5662	X8Ni9	10Ni36	9Ni490	1501-510	X10Ni9
	1.5680	X12Ni5	12Ni20	Z18N5	–	–
	1.5752	14NiCr14	13NiCr12	12NC15	655H13	–
	1.6511	36CrNiMo4	–	36CrNiMo4	817M37	38NiCrMo4
	1.6523	21NiCrMo2	–	20NCD2	805H20	20NiCrMo2
	1.6546	40NiCrMo2-2	40NiCrMo2	40NCD2	3111-Type7	40NiCrMo2
	1.6582	34CrNiMo6	35CrNiMo6	34CrNiMo8	816M40	35NiCrMo6KB
	1.6587	17CrNiMo6	17CrNiMo7	18NCD6	–	–
	1.6657	14NiCrMo13-4	14NiCrMo13	16NCD13	832H13	15NiCrM13
	1.7015	15Cr3	15Cr2	12C3	523M15	–
	1.7033	34Cr4	34Cr4	32C4	530A32	34Cr4
	1.7035	41Cr4	41Cr4	41Cr4	530A40	41Cr4
1.7045	42Cr4	–	42C4TS	530A40	41Cr4	
1.7131	16MnCr5	16MnCr5	16MC4	527M17	16MnCr5	
1.7176	55Cr3	55Cr3	55C3	525A58	55Cr3	
1.7218	25CrMo4	25CrMo4	25CD4	708A25	25CrMo4	
1.7220	34CrMo4	34CrMo4	34CrMo4	708A37	34CrMo4KB	
1.7223	41CrMo4	41CrMo4	42CD4TS	708M40	41CrMo4	
1.7225	42CrMo4	42CrMo4	42CD4	708A42	38CrMo4KB	
1.7262	15CrMo5	–	12CD4	–	–	
1.7335	13CrMo4-5	14CrMo45	15CD3,5	620-440	14CrMo3	
1.7361	32CrMo12	32CrMo12	30CD12	722M24	32CrMo12	
1.7380	10CrMo9-10	–	12CD9.10	1501-622/515	12CrMo910	
1.7715	14MoV6-3	13MoCrV6	–	1503-660-460	–	
1.8159	51CrV4	50CrV4	50CV4	735A51	50CrV4	
1.8509	41CrAlMo7	41CrAlMo7	40CAD6.12	905M39	41CrAlMo7	
1.8523	39CrMoV13-9	39CrMoV13	–	897M39	–	
Werkzeugstähle / Tool steels / Acciai da utensili						
P	1.1545	C105W1	–	C105E2U	–	C100KU
	1.1663	C125W	–	C120E3U	–	C120KU
	1.2067	102Cr6	–	100Cr6	–	–
	1.2080	X210Cr12	–	X200Cr12	BD3	X205Cr12KU
	1.2344	X40CrMoV5-1	–	X40CrMoV5	BH13	X40CrMoV511KU
	1.2363	X100CrMoV5-1	–	X100CrMoV5	BA2	X100CrMoV51KU
	1.2419	105WCr6	–	105WCr5	–	107WCr5KU
	1.2436	X210CrW12	–	X210CrW12-1	–	X215CrW121KU
	1.2542	45WCrV17	–	45WCrV8	BS1	45WCrV8KU
	1.2581	X30WCrV9-3	–	X30WCrV9	BH21	X30WCrV93KU
	1.2601	X165CrMoV12	–	–	–	X165CrMoV12KU
	1.2713	55NiCrMoV6	–	55NiCrMoV7	BH224/5	–
	1.2833	100V1	–	C105E2UV1	BW2	102V2KU
	1.3243	S6-5-2-5	–	Z85WDCV06-05-04-02	BM35	HS6-5-2-5
	1.3255	S18-1-2-5	–	HS18-1-1-5	BT4	HS18-1-1-5
	1.3343	S6-5-2	–	HS6-5-2	BM2	HS6-5-2
	1.3348	S2-9-2	–	HS2-9-2	–	HS2-9-2
	1.3355	S18-0-1	–	HS18-0-1	BT1	HS18-0-1

Werkstoff-Vergleichstabelle

Material – comparison table

Tavola comparativa dei materiali

ISO	Japan Japan Giappone JIS	Schweden Sweden Svezia SS	Russland Russia Russia GOST	Spanien Spain Spagna UNE	USA USA USA AISI/SAE/ASTM
Bau- und Konstruktionsstähle / Structural and constructional steels / Acciai da costruzione					
P	S15C	1350	–	F.111	M1015
	S20C	1450	20	1C22	M1020
	S35C	1572	35	F.113	1035
	S45C	1672	45	F.114	1045
	S55C	1655	55	–	1055
	S58C	–	60	–	1060
	SUM22	1912	–	F.2111-11SMn28	1213
	SUM22L	1914	–	F.2112-11SMnPb28	12L13
	–	–	–	F.2122-10SPb20	11L08
	–	1957	–	F.210.G	1140
	SUM25	–	–	F.2113-12SMn35	1215
	–	1926	–	F.2114-12SMnPb35	12L14
	S15	1370	15	F.1110-C15k	1015
	–	–	40G	–	1035
	S25C	–	25	F.1120-C25k	1025
	SMn438	2120	35G2	F.1203-36Mn6	1335
	SCMn1	–	30G	28Mn6	1330
	S35C	1572	35	–	1035
	S45C	1672	45	F.1140-C45k	1045
	S55C	1655	55	F.1150-C55k	1055
	S50C	1674	50	–	1050
	S58C	1665	60	–	1060
	SUP4	1870	–	–	1095
	SCMnH1	2183	110G13L	F.8251-AM-X120Mn12	A128
	SUJ2	2258	SchCh15	F.1310-100Cr6	52100
	–	2912	–	F.2601-16Mo3	A204Gr.A
	SB450M	–	–	F.2602-16Mo5	4520
	–	–	–	F.2641-15Ni6	A350-LF5
	SL9N53	–	–	F.2645-X8Ni09	A353
	–	–	–	–	2515
	SNC815	–	–	–	3310
	–	–	40ChN2MA	F.1280-35NiCrMo4	4340
	SNCM220	2506	–	F.1522-20NiCrMo2	8620
	SNCM240	–	38ChGNM	F.1204-40NiCrMo2	8740
	SNCM447	2541	38Ch2N2MA	F.1272-40NiCrMo7	4337
	–	–	–	F.1560-14NiCrMo13	–
	–	–	–	F.1560-14NiCrMo13	9310
	SCr415	–	15Ch	–	5015
	SCr430	–	35Ch	F.8221-35Cr4	5132
	SCr440	–	40Ch	F.1211-41Cr4DF	5140
	SCr440	2245	40Ch	F.1202-42Cr4	5140
	–	2173	18ChG	F.1516-16MnCr5	5115
	SUP9	2253	50ChGA	F.1431-55Cr3	5155
	SCM420	2225	20ChM	F.8372-AM26CrMo4	4130
	SCM432	2234	AS38ChGM	F.8331-AM34CrMo4	4135
	SCM440	2244	40ChFA	F.8332-AM42CrMo4	4140
	SCM440	2244	–	F.8332-AM42CrMo4	4140
SCM415	–	–	F.1551-12CrMo4	–	
SFVA12	2216	12ChM	F.2613-14CrMo45	A182-F11	
–	2240	–	F.124.A	–	
SFVAF22A	2218	12Ch8	TU.H	A182F22	
–	–	–	F.2621-13MoCrV6	–	
SUP10	2230	50ChGFA	F.1430-51CrV4	6145	
SACM645	2940	38ChMJuA	F.1740-41CrAlMo7	A355Cl.A	
–	–	–	–	–	
Werkzeugstähle / Tool steels / Acciai da utensili					
P	SK3	1880	U10A-1	F.515	W110
	SK2	–	U13-1	F.5123-C120	W112
	SUJ2	–	Ch	F.5230-100Cr6	L1
	SKD1	–	Ch12	F.5212-X210Cr12	D3
	SKD61	2242	4Ch5MF1S	F.5318-X40CrMoV5	H13
	SKD12	2260	–	F.5227-X100CrMoV5	A2
	SKD2	2140	–	F.5233-105WCr5	–
	–	2312	–	F.5213-X210CrW12	–
	–	2710	5ChW2SF	F.5241-45WCrSi8	S1
	SKD5	–	3Ch2W8F	F.5323-X30WCrV9	H21
	–	–	–	F.5211-X160CrMoV12	–
	SKT4	–	5ChNM	F.520S	L6
	SKS43	–	–	–	W210
	SKH55	2733	R6M5K5	F.5613-6-5-2-5	–
	SKH3	–	–	F.5530-18-1-1-5	T4
	SKH51	2722	R6M5	F.5603-6-5-2	M2
	–	2782	–	F.5607-2-9-2	M7
	SKH2	–	R18	F.5520-18-0-1	T1

Werkstoff-Vergleichstabelle

Material – comparison table

Tavola comparativa dei materiali

ISO	W-Nr.	Deutschland	Belgien	Frankreich	Großbritannien	Italien
		Germany Germania	Belgium Belgio	France Francia	Great Britain Gran Bretagna	Italy Italia
		DIN	NBN	AFNOR	B.S.	UNI
Rost-, säure- und hitzebeständige Stähle / Stainless and heat resisting steels / Acciai inossidabili e leghe refrattarie						
P	1.4000	X6Cr13	–	Z8C12	403S17	X6Cr13
	1.4001	X7Cr14	–	Z8C13FF	403S17	X6Cr13
	1.4006	X12Cr13	–	Z10C13	410S21	X12Cr13
	1.4016	X6Cr17	–	Z8C17	430S17	X8Cr17
	1.4027	GX20Cr14	–	Z20C13M	ANC1B	–
	1.4034	X46Cr13	–	Z44C14	–	X40Cr14
	1.4057	X20CrNi172	–	Z15CN16-02	431S29	X16CrNi16
	1.4104	X12CrMoS17	–	Z13CF17	–	X10CrS17
	1.4113	X6CrMo17-1	–	–	434S17	X8CrMo17
	1.4313	X4CrNi134	–	Z4CND13.4M	425C11	GX6CrNi1304
	1.4408	GX5CrNiMo19-11	–	–	316C16	–
	1.4718	X45CrSi9-3	–	Z45CS9	401S45	X45CrSi8
	1.4724	X10CrAl13	–	Z13C13	–	X10CrAl12
	1.4742	X10CrAl18	–	Z12CAS18	–	–
	1.4747	X80CrNiSi20	–	Z80CNS20-02	443S65	X80CrSiNi20
	1.4762	X10CrAl24	–	Z12CAS25	–	–
	1.4301	X5CrNi1810	–	Z4Cn19-10FF	304S11	X5CrNi1810
	1.4305	X10CrNiSi189	–	Z8CNF19-09	303S22	X10CrNiSi1809
	1.4306	X2CrNi19-11	–	Z1CN18-12	304S11	X3CrNi1811
	1.4308	GX5CrNi19-10	–	Z6CN18.10M	304C15	–
1.4310	X12CrNi177	–	Z11CN17-08	301S21	X12CrNi1707	
1.4311	X2CrNi18-10	–	Z3CN18-07Az	304S61	X2CrNi1811	
1.4401	X5CrNiMo17122	–	Z3CND17-11-01	316S13	X5CrNiMo1712	
1.4429	X2CrNiMoN17-13-3	–	Z3CND17-12Az	316S63	X2CrNiMoN1713	
1.4435	X2CrNiMo18-14-3	–	Z3CND17-12-03	316S11	X2CrNiMo1713	
1.4438	X2CrNiMo18164	–	Z2CND19-15-04	317S12	X2CrNiMo1816	
1.4460	X4CrNiMoN2752	–	Z5CND27-05Az	–	–	
1.4541	X6CrNiTi18-10	–	Z6CNT18-10	321S31	X6CrNiTi1811	
1.4550	X6CrNiNb18-10	–	Z6CnNb18-10	347S20	X6CrNiNb1811	
1.4571	X6CrNiMoTi17-12-2	–	Z6CNDT17-12	320S18	X6CrNiMoTi1712	
1.4581	GX5CrNiMoNb1810	–	Z4CNDNb18.12M	318C17	GX6CrNiMoNb2011	
1.4583	X10CrNiMoNb18-12	–	–	–	X6CrNiMoNb1713	
1.4828	X15CrNiSi20-12	–	Z9CN24-13	309S24	X16CrNi2314	
1.4845	X12CrNi25-21	–	Z8CN25-20	310S16	X6CrNi2521	
1.4864	X12NiCrSi36-16	–	Z20NCS33-16	NA17	–	
1.4865	GX40NiCrSi38-18	–	–	330C11	GX50NiCr3919	
1.4871	X53CrMnNiN21-9	–	Z53CMNS21-09Az	349S54	X53CrMnNiN219	
1.4878	X12CrNiTi18-9	–	Z6CNT18-10	321S51	–	
Gusswerkstoffe / Cast materials / Ghisa						
K	–	GG10	–	F110D	–	G10
	–	GG15	–	F115D	Grade150	G15
	–	GG20	–	F120D	Grade220	G20
	–	GG25	–	F115D	Grade260	G25
	–	GG30	–	F130D	Grade300	G30
	–	GG35	–	F135D	Grade350	G35
	–	GG40	–	F140D	Grade400	–
	–	GGG40	–	FGS400-12	420/12	GS400-12
	–	GGG40.3	–	FGS370-17	370/17	GS042/15
	–	GGG50	–	FGS500-7	500/7	GS500/7
	–	GGG60	–	FGS600-3	600/3	GS600/3
	–	GGG70	–	FGS700-2	700/2	GS700/2
	–	GGGNiMn137	–	S-NM137	S-NiMn137	–
	–	GGGNiCr202	–	S-NC202	S-NiCr202	–

Werkstoff-Vergleichstabelle

Material – comparison table

Tavola comparativa dei materiali

ISO	Japan Japan Giappone JIS	Schweden Sweden Svezia SS	Russland Russia Russia GOST	Spanien Spain Spagna UNE	USA USA USA AISI/SAE/ASTM
Rost-, säure- und hitzebeständige Stähle / Stainless and heat resisting steels / Acciai inossidabili e leghe refrattarie					
P	SUS403	2301	08Ch13	F.3110-X6Cr13	403
	SUS410S	2301	08Ch13	F.8401-AM-X12Cr13	410S
	SUS410	2302	12Ch13	F.3401-X10Cr13	410
	SUS430	2320	12Ch17	F.3113-X6Cr17	430
	SCS2	—	20Ch13L	—	—
	—	2321	40Ch13	F.3405-X45Cr13	—
	SUS431	2383	20Ch17N2	F.3427-X19CrNi172	431
	SUS430F	—	—	F.3117-X10CrS17	430F
	SUS434	2384	—	F.3116-X6CrMo171	434
	SCS5	—	—	—	—
	SCS14	—	07Ch18N10G2S2M2L	F.8414-AM-X7CrNiMo2010	CF-8M
	SUH1	—	40Ch9S2	F.3220-X4CrSi09-03	HNv3
	—	—	10Ch13SJu	F.3152-X10CrAl13	—
	SUH21	—	15Ch18SJu	F.3153-X10CrAl18	—
	SUH4	—	—	F.3222-X80CrSiNi20-02	HNv6
—	—	—	F.3154-X10CrAl24	—	
M	SUS304	2332	08Ch18N10	F.3504-X5CrNi1810	304
	SUS303	2346	—	F.3508-X10CrNiS18-09	303
	SCS19	2352	03Ch18N11	F.3503-X2CrNi1810	304L
	SCS13	2333	07Ch18N9L	—	CF-8
	SUS301	2331	—	F.3517-X12CrNi177	301
	SUS304LN	2371	—	F.3541-X2CrNiNi1810	304LN
	SUS316	2347	—	F.3534-X5CrNiMo17122	316
	—	2375	—	F.3543-X2CrNiMoN17313	316LN
	SUS316L	2353	03Ch17N14M3	F.3533-X2CrNiMo17132	316L
	SUS317L	2367	—	F.3539-X2CrNiMo18164	317L
	SUS329J1	2324	—	F.3309-X8CrNiMo27-05	329
	SUS321	2337	06Ch18N10T	F.3523-X6CrNiTi1810	321
	SUS347	2338	08Ch18N12B	F.3524-X6CrNiNb1810	347
	SUS316Ti	2353	10Ch17N13M2T	F.3535-X6CrNiMoTi17122	316Ti
	SCS22	—	—	—	—
	—	—	—	—	318
	SUH309	—	20Ch20N14S2	F.3312-X15CrNiSi20-12	309
	SUH310	2361	20Ch23N18	—	310S
	SUH330	—	—	F.3313-X12CrNiSi36-16	330
	SCH15	—	—	—	—
	SUH35	—	55Ch20G9AN4	F.3217-X53CrMnNiN21-09	EV8
	SUS321	—	—	—	321
Gusswerkstoffe / Cast materials / Ghisa					
K	FC10	0110-00	Sc10	FG10	A48-20B
	FC15	0115-00	Sc15	FG15	A48-25B
	FC20	0120-00	Sc20	FG20	A48-30B
	FC25	0125-00	Sc25	FG25	A48-40B
	FC30	0130-00	Sc30	FG30	A48-45B
	FC35	0135-00	Sc35	FG35	A48-50B
	—	0140-00	Sc40	Ft40D	A48-60B
	FCD40	0717-02	VC42-12	—	60-40-18
	—	0717-15	VC42-12	—	—
	FCD50	0727-02	VC50-2	—	65-45-12
	FCD60	0732-03	VC60-2	—	80-55-06
	FCD70	0737-01	VC70-2	—	100-70-03
	—	—	—	—	—
	—	—	—	—	A439TypeD-2

Härtevergleich

Hardness – comparison table

Comparazione delle durezza

Zugfestigkeit Tensile strength Resistenza alla trazione N/mm ²	Vickers		Brinell	Rockwell	Brinell
	HV		HB	HRC	„SH“
700		200		–	28
740		210		–	29
770		220		–	30
810		230		19,2	31
840		240		21,2	33
880		250		23,0	34
910		260		24,7	35
950		270		26,1	36
980		280		27,6	37
1020		290		29,0	39
1050		300		30,0	40
1090		310		31,5	41
1120		320		32,9	42
1150		330		33,8	43
1190		340		34,9	44
1230		350		36,0	45
1260	360		359	37,0	46
1300	370		368	38,0	47
1330	380		373	38,9	48
1370	390		385	39,8	49
1400	400		393	40,7	50
1440	410		400	41,5	51
1470	420		407	42,3	52
1510	430		416	43,2	53
1540	440		423	44,0	54
1580	450		429	44,8	55
1610	460		435	45,5	56
1650	470		441	46,3	57
1680	480		450	47,0	58
1720	490		457	47,7	59
1750	500		465	48,3	60
1790	510		474	49,0	61
1820	520		482	49,6	62
1860	530		489	50,3	63
1890	540		496	50,9	64
1930	550		503	51,5	65
1960	560		511	52,1	66
2000	570		520	52,7	67
2030	580		527	53,3	68
2070	590		533	53,8	69
2100	600		533	54,4	70
2140	610		543	54,9	71
2170	620		549	55,4	72
2210	630		555	55,9	73
2240	640		561	56,4	74
2280	650		568	56,9	75
2310	660		574	57,4	75
2350	670		581	57,9	76
2380	680		588	58,7	77
2410	690		595	58,9	78
2450	700		602	59,3	79
2480	710		609	59,8	80
2520	720		616	60,2	81
2550	730		622	60,7	82
2590	740		627	61,1	83
2630	750		633	61,5	83
2660	760		639	61,9	84
2700	770		644	62,3	85
2730	780		650	62,7	86
2770	790		656	63,1	86
2800	800		661	63,5	87
2840	810		666	63,9	87
2870	820		670	64,3	88
2910	830		677	64,6	89
2940	840		682	65,0	89
2980	850		–	65,3	90
3010	860		–	65,7	90
3050	870		–	66,0	91
3080	880		–	66,3	91
3120	890		–	66,6	92
3150	900		–	66,9	92
3190	910		–	67,2	–
3220	920		–	67,5	–
3260	930		–	67,7	–
3290	940		–	68,0	–

Freiflächenverschleiß / Flank wear / Usura sul fianco

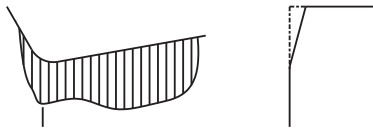

Abrasive Verschleißform, bei der eine mechanische Belastung die Entstehung einer ebenen Fläche an der Freifläche der Schneidkante bewirkt. Zu großer Freiflächenverschleiß führt zu schlechter Oberflächengüte, Ungenauigkeit und zunehmender Reibung.

Abhilfe:

- Schnittgeschwindigkeit verringern
- Verschleißfestere Sorte wählen

Abrasive wear, resulting from mechanical stresses – can be seen as a flat on the clearance of the cutting edge. Excessive flank wear result in bad surface finish, inaccuracy and increasing friction.

Solution:

- reduce cutting speed
- choose more wear resistant grade

Usura abrasiva, dovuta a stress meccanici, che appare come in piano sullo spigolo tagliente. Una usura eccessiva del fianco porta a una cattiva finitura superficiale, ridotta precisione e crescente frizione.

Soluzioni:

- ridurre la velocità di taglio
- scegliere un grado con migliore resistenza all'usura

Kerbverschleiß / Wear by intonation / Usura ad intaglio



Kerbverschleiß an der Hauptschneide entsteht dort, wo diese direkt mit dem Werkstück zusammentrifft. Die Ursache ist auf Hartpartikel des Werkstückmaterials zurückzuführen. Großer Kerbverschleiß beeinflusst die Spanbildung und kann zum Bruch der Wendeschneidplatte führen.

Abhilfe:

- Vorschub reduzieren
- Verschleißfestere Sorte wählen

Wear by intonation on the main cutting edge can be seen where the cutting edge and workpiece has its contact. The main reason are hard particles in the workpiece material. Excessive wear by intonation influences chip formation and can also lead to insert breakage.

Solution:

- reduce feed rate
- choose more wear resistant grade

L'usura per scheggiatura del tagliente principale è dove il tagliente ed il pezzo si toccano. La ragione principale è la presenza di componenti duri all'interno del pezzo da lavorare. Un usura eccessiva per scheggiatura influenza la formazione di truciolo che può portare alla rottura dell'inserto.

Soluzioni:

- ridurre l'avanzamento
- scegliere un grado con migliore resistenza all'usura

Kolkverschleiß / Crater wear / Usura a cratere



Verschleiß auf der Spanfläche hervorgerufen durch Diffusion und Abrasion. Der Kolkverschleiß entsteht durch das Abtragen von Schneidstoff (Schleifvorgang) und Diffusion an der heißesten Stelle der Schneide (Kontakt Span-Schneidstoff). Großer Kolkverschleiß verändert die Geometrie der Schneide, kann die Spanbildung stören und die Schneide schwächen.

Abhilfe:

- Schnittgeschwindigkeit verringern
- Vorschub senken
- Beschichtete Hartmetallsorte einsetzen
- Positive Wendeschneidplatten-geometrie wählen

Wear on the rake angle caused by diffusion and abrasion. Crater wear results from the contact chip / cutting material and diffusion at the hot part of the cutting edge. Excessive crater wear changes the geometry, can disturb chip-formation and can weaken the cutting edge.

Solution:

- reduce cutting speed
- reduce feed rate
- use coated carbide grades
- choose positive cutting geometry

L'usura della superficie di taglio causata da diffusione e abrasione. L'usura a cratere risulta dal contatto fra il truciolo del materiale lavorato e la diffusione sulla parte calda del tagliente. Un'eccessiva usura modifica la geometria, può disturbare la formazione di truciolo ed indebolire il tagliente.

Soluzioni:

- ridurre la velocità di taglio
- ridurre l'avanzamento
- usare gradi di carburo rivestiti
- scegliere geometria inserto positivo

Plastische Deformation / Plastic deformation / Deformazione plastica



Verschleiß infolge hoher Temperaturen und Druck an der Schneidkante verursacht durch hohe Schnittgeschwindigkeiten und Vorschübe sowie harte Werkstückmaterialien. Plastische Deformation führt zu schlechter Spankontrolle und Oberflächengüte und unter Umständen zum Bruch der Wendeschneidplatte.

Abhilfe:

- Schnittgeschwindigkeit verringern
- Vorschub senken
- Verschleißfestere Hartmetallsorte wählen

Wear caused by high temperature and stress on the cutting edge - mainly because of high cutting speeds and feed rates and hard workpiece materials. Plastic deformation leads to bad chip formation and surface quality and in some cases to insert breakage.

Solution:

- reduce cutting speed
- reduce feed rate
- use more wear resistant carbide grades

Usura causata dall'alta temperatura d'esercizio combinata ad una pressione sul tagliente, principalmente dovuta ad elevate velocità di taglio e avanzamenti insieme alla durezza del materiale da lavorare. La deformazione plastica causa una cattiva formazione di truciolo e in alcuni casi la rottura dell'inserto.

Soluzioni:

- ridurre la velocità di taglio
- ridurre l'avanzamento
- scegliere un grado con migliore resistenza all'usura

Aufbauschneide / Build-up edge / Tagliente di riporto

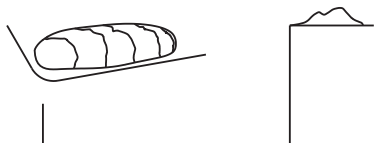

Aufbauschneide auf der Spanfläche durch Verschweißen von Werkstückmaterial mit dem Schneidstoff. Neben der Geometrieänderung kann es beim Abreißen der Aufbauschneide zu Kantenausbrüchen kommen. Die Bildung einer Aufbauschneide verursacht eine schlechte Oberflächengüte und kann bis hin zum Bruch der Wendeschneidplatte führen.

Abhilfe:

- Schnittgeschwindigkeit erhöhen
- Positive Schneidengeometrie wählen
- Einsatz von beschichteten Hartmetallen oder Cermets
- Kühlschmiermittel verwenden

Welding of workpiece material on the cutting material. Cutting geometry will change and build-up edge will generally lead to cutting edge outbreaks. Build-up edges lead to bad surface finish and breakage of the insert.

Solution:

- increase cutting speed
- choose positive cutting geometry
- use coated carbide grades or Cermets
- use lubricant

Le increspature del materiale sull'inserto. La geometria di taglio è cambiata e può portare a fratture del tagliente. Queste increspature portano ad una cattiva finitura superficiale ed alla rottura dell'inserto.

Soluzioni:

- aumentare la velocità di taglio
- usare un grado di carburo rivestito o Cermet
- usare lubrificante

Kantenausbrüche / Cutting edge outbreaks / Fratture del tagliente



Statt einer gleichmäßigen Abnutzung der Schneidkante brechen hier kleine Teile der Schneide aus. Die Hauptursache hierfür liegt im unterbrochenen Schnitt. Kantenausbrüche führen zu einer schlechten Oberflächengüte und starkem Freiflächenverschleiß.

Abhilfe:

- Vorschub zu Beginn der Bearbeitung verringern
- Hartmetallsorte mit höherer Zähigkeit wählen
- Wendeschneidplatte mit stabilerer Schneidengeometrie wählen

Instead of having uniform wear, small parts of the cutting edge break away. The main reason is interrupted cutting. Cutting edge outbreaks lead to bad surface finish and excessive flank wear.

Solution:

- reduce feed rate when starting machining
- choose carbide grade with higher toughness
- use indexable insert with stronger cutting edge

Invece di avere una usura uniforme, piccole parti del tagliente si danneggiano. La ragione principale è il taglio interrotto. La frattura del tagliente porta una cattiva finitura superficiale ed una eccessiva usura del fianco.

Soluzioni:

- ridurre l'avanzamento quando si inizia la lavorazione
- scegliere geometria inserto positivo
- scegliere un grado con maggiore tenacità
- scegliere un inserto con un tagliente più robusto

Plattenbruch / *Insert breakage* / Rottura dell'inserto



Der Bruch der Wendeschneidplatte bringt häufig eine Beschädigung von Werkzeug und Werkstück mit sich. Die Ursachen sind oft zu hoher Verschleiß oder Belastung der Schneide, können aber auch von Maschine und Werkstück abhängig sein.

- Abhilfe:**
- Zähere Sorte wählen
 - Vorschub und/oder Schnitttiefe verringern
 - Wendeschneidplatte mit größerer Stabilität und Eckenradien wählen

Insert breakage will mainly damage the tool and work piece. The reasons are mainly excessive wear or stress on the cutting edge but can also be the machine or the workpiece.

- Solution:**
- choose tougher grade
 - reduce feed rate and/or depth of cut
 - choose indexable insert with higher stability or larger corner radius, if possible single sided indexable inserts

Una rottura dell'inserto significa in generale deterioramento dell'utensile e del pezzo. Le cause sono spesso una usura o una pressione eccessiva sul tagliente. Può anche dipendere dalla lavorazione del pezzo.

- Soluzioni:**
- scegliere un grado più tenace
 - ridurre l'avanzamento o la profondità di taglio
 - scegliere un inserto più stabile o con un angolo di raggio più grande

Kammrisse / *Thermal cracks* / Fessure



Bildung von Rissen senkrecht zur Schneidkante, hervorgerufen durch Temperaturwechsel im unterbrochenen Schnitt. Kammrisse führen zu schlechter Oberflächenqualität und Kantenausbrüchen.

- Abhilfe:**
- Einsatz einer Sorte mit hoher Zähigkeit
 - Kontinuierliche Kühlschmiermittelzuführung

Cracks vertical to the cutting edge, resulting from changing temperature during interrupted cutting.

- Solution:**
- use a carbide grade with higher toughness
 - pay attention to the use of lubricants – either in good quantity or non at all

Formazione di fessure perpendicolari, risultato dello shock termico durante il taglio interrotto. Le fessure originano una finitura superficiale mediocre e fratture del tagliente.

- Soluzioni:**
- usare un grado con maggiore tenacità
 - refrigerante di continuo

Berechnungseinheiten / Calculation units / Unità di misura

D_c	Schneiddurchmesser <i>Cutting diameter</i> Diametro	[mm]	n	Drehzahl <i>Revolutions</i> Numero di giri	[min ⁻¹]
a_e	Eingrieffsbreite (radial) <i>Radial cutting depth</i> Profondità di passata radiale	[mm]	z	Wirksame Zähnezahl am Fräser <i>Effective number of inserts</i> Numero taglienti effettivo	
a_p	Schnitttiefe (axial) <i>Depth of cut (axial)</i> Profondità di taglio	[mm]	h_m	Mittlere Spanungsdicke <i>Average chip thickness</i> Spessore medio truciolo	[mm]
f	Vorschub pro Umdrehung <i>Feed rate per revolution</i> Avanzamento al giro	[mm/U]	Q	Zeitspanvolumen <i>Chip removal rate</i> Volume truciolo	[cm ³ /min]
f_z	Vorschub pro Zahn <i>Feed per tooth</i> Avanzamento al tagliente	[mm/Zahn]	P_c	Netto-Antriebsleistung <i>Power</i> Assorbimento potenza	[kW]
V_c	Schnittgeschwindigkeit <i>Cutting speed</i> Velocità di taglio	[mm/min]	k_c	Spezifische Schnittkraft <i>Special cutting force</i> Forza di taglio specifica	[N/mm ²]
V_f	Vorschubgeschwindigkeit <i>Feed rate</i> Velocità di avanzamento	[mm/min]			

Formeln / Formulas / Formule

Schnittgeschwindigkeit

Cutting speed
Velocità di taglio

Drehzahl

Revolutions
Numero di giri

Vorschubgeschwindigkeit

Feed rate
Velocità di avanzamento

Vorschub pro Umdrehung

Feed rate per revolution
Feed rate per revolution

Vorschub pro Zahn

Feed per tooth
Avanzamento al tagliente

Mittlere Spanungsdicke

Average chip thickness
Spessore medio truciolo

Zeitspanvolumen

Chip removal rate
Volume truciolo

Netto-Antriebsleistung

Power
Assorbimento potenza

$$v_c = \frac{\pi \cdot D_c \cdot n}{1000}$$

$$n = \frac{v_c \cdot 1000}{\pi \cdot D_c}$$

$$v_f = f_z \cdot z \cdot n$$

$$f = \frac{v_f}{n}$$

$$f_z = \frac{v_f}{z \cdot n}$$

$$h_m = f_z \cdot \sqrt{\frac{a_e}{D_c}}$$

$$Q = \frac{a_p \cdot a_e \cdot v_f}{1000}$$

$$P_c = \frac{a_p \cdot a_e \cdot v_f \cdot k_c}{6} \cdot 10^{-7}$$

für / for / per $a_e \leq 0,25 D_c$

Außenfräsen – zirkular

External milling – circular

Fresatura Esterna ad interpolazione

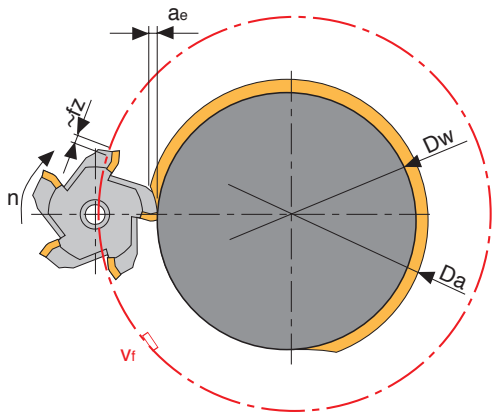

Innenfräsen – zirkular

Internal milling – circular

Fresatura Interna ad interpolazione

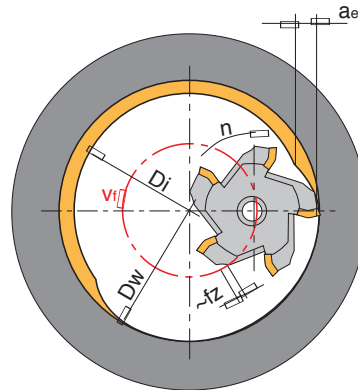

Vorschubgeschwindigkeit (Bahngeschwindigkeit Fräsermittelpunkt)

Feed rate (on centre of cutter diameter)

Velocità di avanzamento (riferimento centro corpo fresa)

$$V_f = \left(1 + \frac{d_1}{D_w} \right) n \cdot f_z \cdot z$$

$$V_f = \left(1 - \frac{d_1}{D_w} \right) n \cdot f_z \cdot z$$

Eingriffsbreite / Cutting width / Fascia di presa

$$D_e = \frac{D_a^2 - D_w^2}{4 \cdot (D_w + d_1)}$$

$$a_e = \frac{D_a^2 - D_i^2}{4 \cdot (D_w - d_1)}$$

Berechnungsbeispiel Außenfräsen – zirkular

Calculation example: External milling – circular

Esempio di calcolo: Interpolazione circolare esterna

Fräsertyp / Type of milling cutter / Tipo di corpo fresa	60PA.40R.E12
Fräserdurchmesser / Diameter of milling cutter / Diametro corpo fresa	40 mm
Zähnezahl / Number of inserts / Numero di taglienti	z: 3
Werkstückdurchmesser / Work piece diameter / Diametro del pezzo	Dw: 60 mm
Ausgangsdurchmesser / Starting diameter / Diametro di partenza	Da: 65 mm
Spindeldrehzahl / Spindle R.P.M. / Numero di giri mandrino	n: 2500 U/min
Vorschub pro Zahn / Feed rate per tooth / Avanzamento a tagliente	fz: 0,05 mm

Vorschubgeschwindigkeit

Feed rate

Velocità di avanzamento

$$V_f = \left(1 + \frac{40}{60} \right) 2500 \cdot 0,05 \cdot 3 = 625 \text{ mm/min}$$

Radiale Eingriffsbreite

Radial cutting depth

Profondità di passata radiale

$$\frac{65 - 60}{2} = 2,5 \text{ mm}$$

Effektive radiale Eingriffsbreite

Effective radial cutting depth

Profondità di passata radiale effettiva

$$a_e = \frac{65^2 - 60^2}{3 \cdot (60 + 40)} = 2,08 \text{ mm}$$

Gleich- und Gegenlauffräsen

Conventional and climb milling

Fresatura in concordanza e discordanza

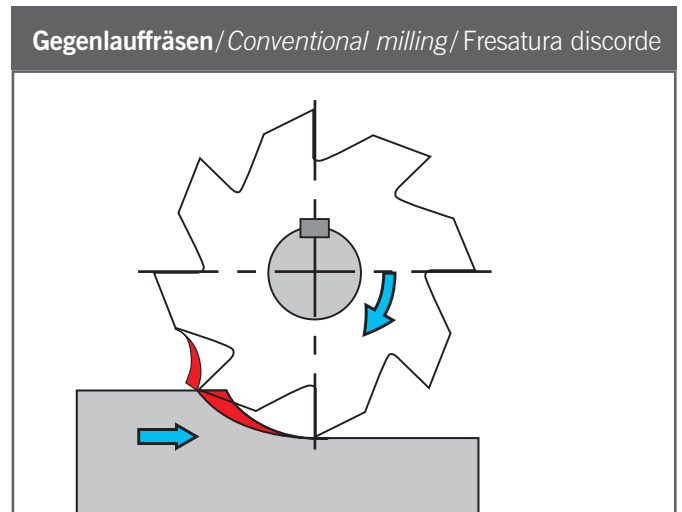
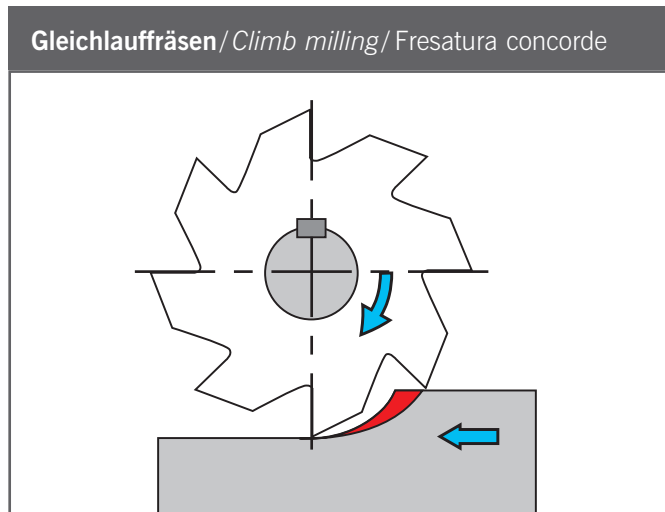

Richtung der Vorschubbewegung gegenüber der Schnittbewegung / Feed rate direction against the cutting direction /

Direzione del movimento di avanzamento riferito all'avanzamento di taglio

Vor- und Nachteile / Advantages and dis-advantages / Pro e Contro



Fräser tritt bei Spanungsdicke

$h = 0$ mm aus dem Werkstück aus.

Cutter exits component at chip thickness

$h = 0$ mm

Il tagliente completa l'operazione di taglio

a sezione truciolo $h = 0$ mm

• **es tritt kein Rückfedern auf**

No burnishing

Senza spinte radiali (flessioni)

• **es entstehen so bessere Oberflächengüten**

Better surface finish

Si genera una qualità superficiale migliore

• **die Schnittkraft drückt das Werkstück auf den Tisch**

The cutting forces presses component into the table

Le forze di taglio sono orientate in direzione del piano di lavoro

• **größere Vorschübe, Spannungsdicken und Vc dadurch möglich**

Therefore higher feed rate, chip thickness and cutting

speed possible. Reduced cutting pressure

Possibile utilizzare avanzamenti e velocità di taglio maggiori

Fräser dringt zuerst bei Spanungsdicke

$h = 0$ mm ein.

Cutter enters at chip thickness $h = 0$ mm

Il tagliente inizia l'operazione di taglio a sezione

truciolo $h = 0$ mm

• **dadurch entstehen sehr hohe Temperaturen beim Anschnitt**

Thereby creating high temperature at cutting point

Si generano temperature più elevate

• **die Oberfläche verfestigt sich**

Hardening of the surface

Indurimento della superficie

• **Plattenbruch kann entstehen durch anhaftende Späne**

Inserts breakage can happen due to swarf welding

Può generare rotture dovute a incollaggio del truciolo

• **starker Freiflächenverschleiß = geringere Standzeiten**

Severe relief angle wear = reduced tool life

Elevata usura sul fianco = minor durata del tagliente

• **Austritt der Schneide erzeugt Schwingungen – rattern**

Exit of insert can create rubbing – burnishing effect

and work hardening

In uscita il tagliente genera delle vibrazioni

Fazit / Result / Conclusioni:

Gleichlauffräsen ist grundsätzlich dem Gegenlauffräsen vorzuziehen. / *Climb milling is generally the preferred method.*

Fresatura concorde è generalmente preferibile alla fresatura discorde.

Positionierung des Fräswerkzeuges

Positioning of the milling cutter

Posizionamento della fresa

Günstig

Recommended / Sugerito

Gleichlaufräsen

Climb milling

Fresatura concorde

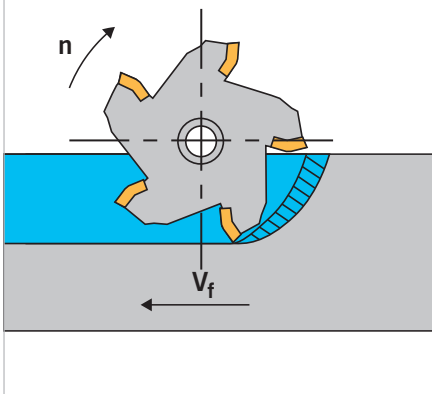

Gleich- und Gegenlaufräsen

Conventional and climb milling

Fresatura in concordanza e discordanza

Das Gleichlaufräsen ist dem Gegenlaufräsen vorzuziehen soweit es Maschine, Aufspannung und Werkstück erlauben.

Providing the machine, workholding and component allows it; climb milling is the preferred method

La fresatura concorde è di gran lunga preferibile alla fresatura discorde come macchina e bloccaggio del pezzo.

Ungünstig

Not recommended / Sconsigliato

Gegenlaufräsen

Conventional milling

Fresatura discorde

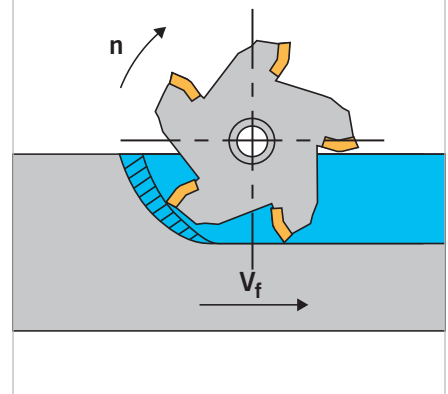

Fräseranstellung tangential

Cutter positioning tangential

Posizionamento tangenziale concorde

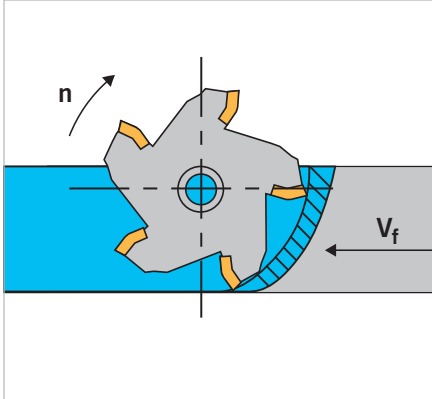

Fräseranstellung

Cutter positioning

Posizionamento

Das Fräserwerkzeug sollte möglichst tangential aus dem Werkstück austreten.

Ideally the milling cutter should exit the workpiece tangentially.

La fresa deve essere posizionata per una fresatura quanto più tangenziale possibile.

Fräseranstellung abseits der Tangente

Cutter positioning opposite of tangential

Posizionamento tangenziale discorde

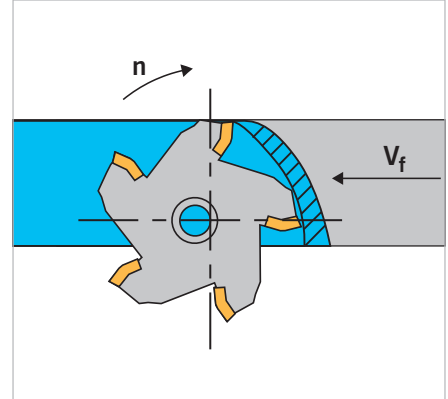

Werkstücklage tangential

Workpiece positioning tangential

Posizione del pezzo lungo la tangente

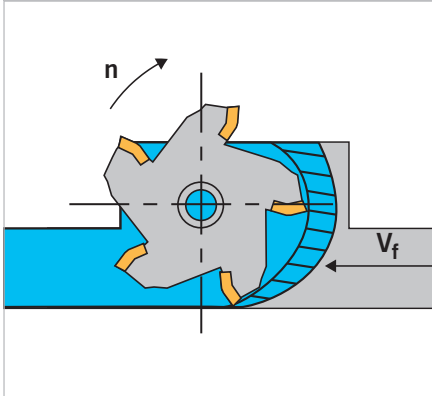

Werkstücklage

Workpiece positioning

Posizione del pezzo

Nach Möglichkeit sollte das Werkstück so eingespannt werden, dass das Fräserswerkzeug über die ganze Bearbeitungslänge tangential austreten kann.

Ideally the workpiece should be clamped so that milling cutter can exit tangentially along the entire machining length.

Posizionare la fresa in modo che la tangente rimanga a contatto con il pezzo.

Werkstücklage abseits der Tangente

Workpiece positioning opposite of tangential

Posizione del pezzo oltre la tangente

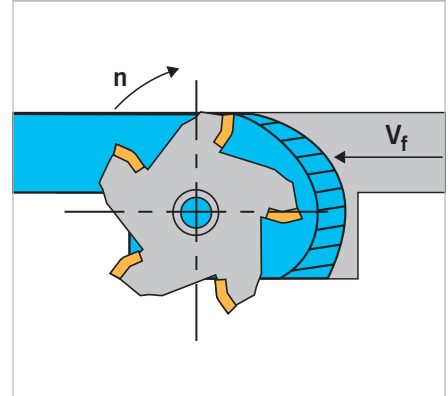

Positionierung des Fräsworkzeuges

Positioning of the milling cutter

Posizionamento della fresa

Günstig

Recommended / Suggestito

Tangentiale Austritt

Exit tangential

Uscita lungo la tangente

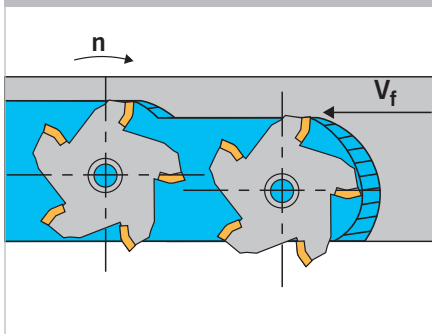

Überdeckung

Stepover

Fascia in presa

Entweder Gleichlaufräsen, oder wie im linken Beispiel gezeigt auf tangentialen Austritt des Fräsworkzeugs achten.

Use climb milling, or as shown on the left example take care of tangential exit of milling cutter.

Gestire le fasce in presa evitando condizioni di uscita del tagliente lungo l'asse della fresa, oppure adottare fresatura concorde.

Ungünstig

Not recommended / Sconsigliato

Austritt abseits der Tangente

Exit opposite tangential

Uscita lungo l'asse della fresa

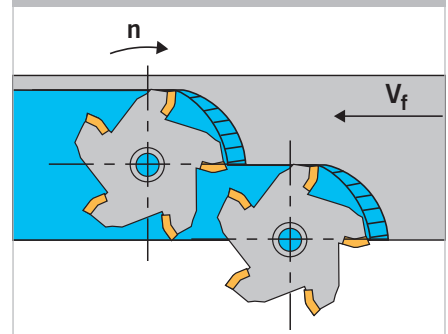

Fräsergröße ≥ 20%

Cutter size ≥ 20%

Fascia in presa ≥ 20%

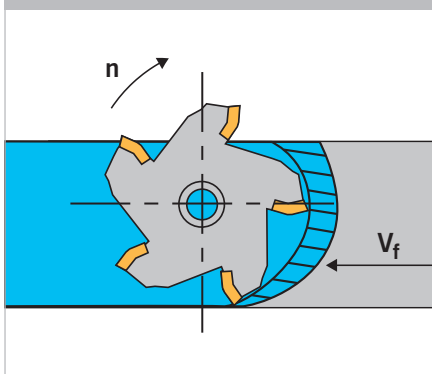

Fräsergröße

Fräsergröße

Fräsergröße

Beim Planfräsen sollte der Durchmesser des Fräsworkzeugs 20–30 % größer sein als das Werkstück.

When face milling the milling cutter diameter should be 20–30 % larger than workpiece.

Nella fresatura frontale la fresa deve essere del 20–30 % maggiore rispetto al pezzo.

$$d_1 = a_e \times 1,2 - 1,3$$

Fräsergröße < 20%

Cutter size < 20%

Fascia in presa < 20%

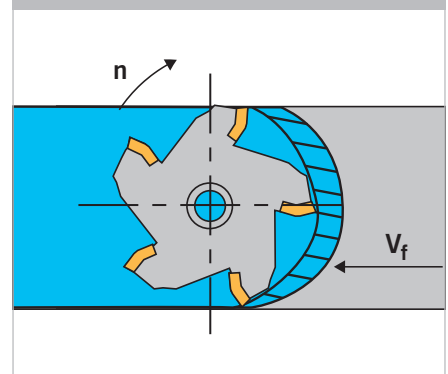

Lage der Werkzeugachse zur erzeugten Oberfläche

Orientation of axis to surface

Orientamento asse utensile rispetto alla superficie da lavorare

Umfangsfräsen / Periphery milling / Fresatura periferica o tangenziale

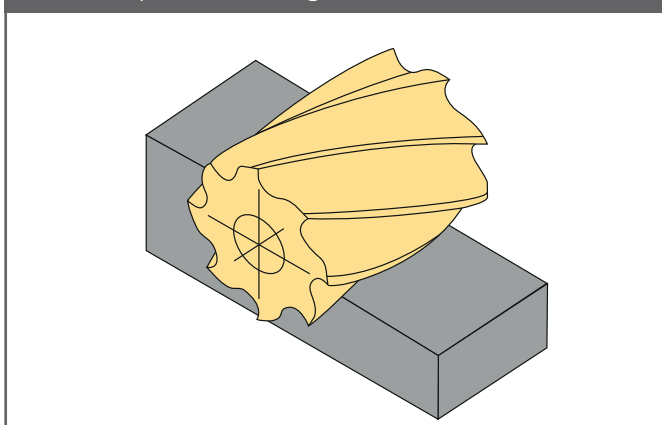

Stirnfräsen / Face milling / Spianatura

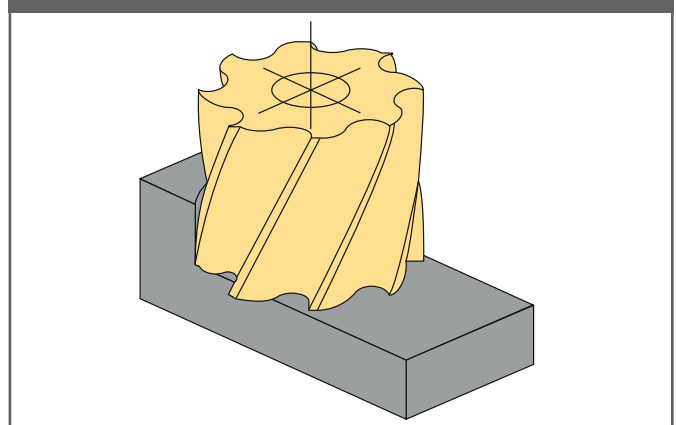

Einstellwinkel zu hm und f_z Calculation of chip thickness Angolo di attacco, hm ed f_z

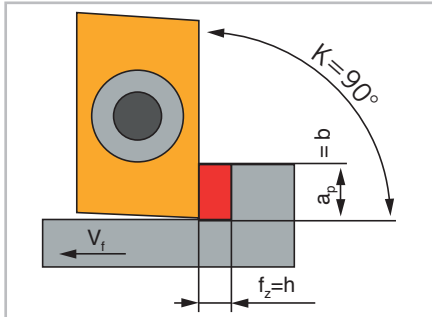

Fräser mit 90° Einstellwinkel
Milling with 90 approach angle
Fresatura con angolo di attacco 90°

- **dünwandige Werkstücke**
Thinwalled components
Pezzo con pareti sottili
- **schwach aufgespannte Werkstücke**
Weak workpiece clamping
Pezzi debolmente bloccati
- **wenn 90° erforderlich sind**
When 90° is required
Dove richiesto 90°

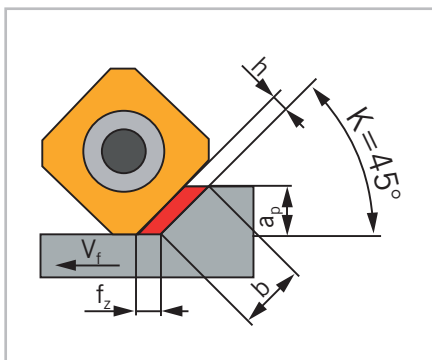

Fräser mit 45° Einstellwinkel
Milling cutter with 45° approach angle
Fresatura con angolo di attacco 45°

- **erste Wahl für allg. Bearbeitungen**
1st choice for general machining
Prima scelta per la fresatura di spianatura
- **vermindert Schwingungen**
Reduces vibration
• Riduce le vibrazioni
- **hohe Spanvolumina möglich**
Possible high chip volume
Elevato volume truciolo

Einstellwinkel / Mittenspanndicke hm Approach angle / average chipthickness hm Angolo di attacco / spessore medio del truciolo hm

Einstellwinkel Approach angle Angolo di attacco	Zahnvorschub Feed per tooth Avanzamento a tagliente	Spanungsdicke hm Chip thickness hm Spessore truciolo hm
90°	f_z	f_z
75°	f_z	$0,96 \times f_z$
70°	f_z	$0,94 \times f_z$
60°	f_z	$0,86 \times f_z$
45°	f_z	$0,707 \times f_z$

Die Reduzierung des Einstellwinkels vermindert die Spandicke hm .

By reducing the approach angle reduces the chipthickness hm . To obtain the correct chip thickness, please apply above calculation.

La riduzione dell'angolo di attacco riduce lo spessore del truciolo.

Einstellwinkel / Schnittkräfte Approach angle / cutting forces Angoli di taglio / Forze di taglio

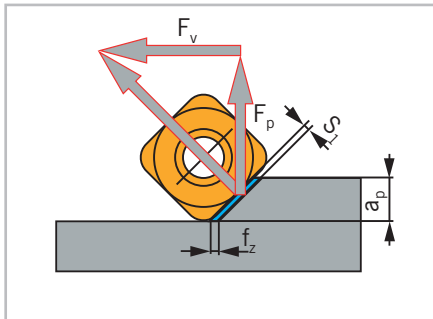

Axialkraft F_p und Radialkraft F_v sind ungefähr gleich groß. Dadurch ergibt sich eine geringere Beanspruchung der Frässpindel auf Durchbiegung. Die günstige Verteilung der Schnittbelastung auf einem langen Teil der Schneidkante ergibt positive Standzeiteffekte. Bei spröden Werkstückstoffen werden die Randausbrüche reduziert.

Axial force F_p and radial force F_v are approximately equal. Thereby causing less stress to the spindle. The even distribution of cutting forces has a positive effect on tool life.

Forza assiale F_p e forza radiale F_v sono circa le stesse dimensioni. Questo si traduce in meno stress radiale sul mandrino che causerebbe flessione. La distribuzione delle forze di taglio su una lunga parte del tagliente è suggerita.

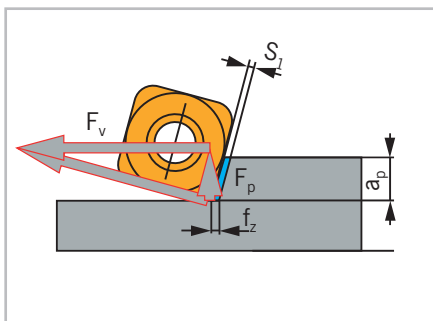

Durch die Wahl eines Anstellwinkels $> 45^\circ$ verringert sich die Axialkraft F_p . Die relativ höhere Radialkraft F_v führt zu einer stärkeren Querbelastung der Spindel. Die spezifische Belastung der Schneidkante erhöht sich durch die zunehmende Spandicke s_1 .

When choosing a cutter with $> 45^\circ$ approach angle the axial force F_p will reduce. The relative higher radial force F_v leads to more stress to the spindle. The load on the cutting edge increases due to the increasing chip thickness.

Scegliendo un angolo di attacco $> 45^\circ$, la forza assiale F_p è ridotta mentre la forza radiale F_v aumenta caricando maggiormente l'asse mandrino. Il carico sul tagliente aumenta avendo un parte inferiore di tagliente in presa.

Die Auswahl des Einstellwinkels beeinflusst die Spandicke, Schnittkräfte und Standzeiten. Die Reduzierung des Einstellwinkels vermindert die Spandicke.

The selection of approach angle affects the chip thickness, cutting forces and tool life. Reducing the approach angle reduces the chip thickness.

La scelta dell'angolo di attacco influisce sullo spessore truciolo, forze di taglio e la durata inserto. Riducendolo si diminuisce lo spessore truciolo.

Zahnteilung / Pitch / Passo

Weite oder normale Zahnteilung / Coarse or normal pitch / Passo largo o normale

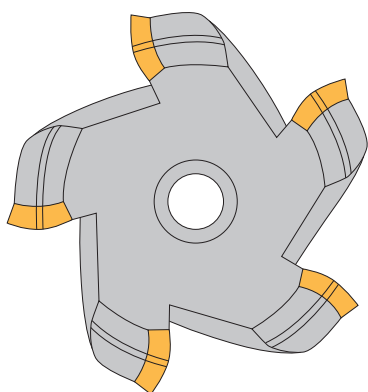

• bei Aluminium-Legierungen

For aluminium-alloys
Per leghe di alluminio

• Buntmetallen

Non-ferrous materials
Leghe ferrose

• Kunststoffen

Plastics
Materie plastiche

• leistungsschwache Maschinen

Low powered machine
Macchine con bassa potenza

• instabile Arbeitsbedingungen

Unstable machining conditions
Condizioni di lavoro instabili

Enge Zahnteilung / Fine pitch / Passo stretto

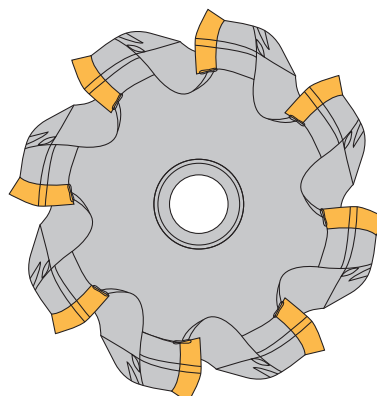

• Stahl- und Eisenguss

Steel and cast steel
Acciaio e ghisa

• leistungsstarke Maschinen

Strong machine
Macchine con elevata potenza

• stabile Aufspannung des Werkstücks

Stable workpiece clamping
Condizioni di lavoro stabili

• stabile Rahmenbedingungen

Stable machining conditions
Condizioni di lavoro stabili

• maximales Zeit-/Spannvolumen

Max chip removal rate
Max volume truciolo

Gewindefräsen / Thread milling / Fresatura di filetti

Das Gewindefräsen setzt eine Fräsmaschine mit einer Dreiachsen-Bahnsteuerung (Helicoidal Interpolation) voraus. Hierbei beschreibt der Gewindefräser eine Bewegung entlang einer Schraubenlinie, d.h. es erfolgt eine kreisförmige Bewegung in der X-/Y-Ebene kombiniert mit einer linearen Verschiebung in Z-Richtung. Während eines Umlaufes wird das Werkzeug um eine Steigungslänge vertikal versetzt.

In order to perform a thread milling operation, a milling machine with three-axis control capable of helical interpolation is required. Helical interpolation is a CNC function producing tool movement along a helical path. This helical motion combines circular movement in one plane with a simultaneous linear motion in a plane perpendicular to the first. For example, the path from one point to another point of the cylinder combines a circular movement in the X/Y-plane with a linear displacement in the Z direction. During one such orbit, the tool will shift vertically one pitch length.

La fresatura di filetti richiede una macchina fre-satrice a controllo numerico capace di generare interpolazioni circolari su assi X/Y e combinando l'avanzamento lungo l'asse Z. Questo permette la generazione di un percorso circolare durante lo spostamento in Z del valore del passo e con il mandrino in rotazione.

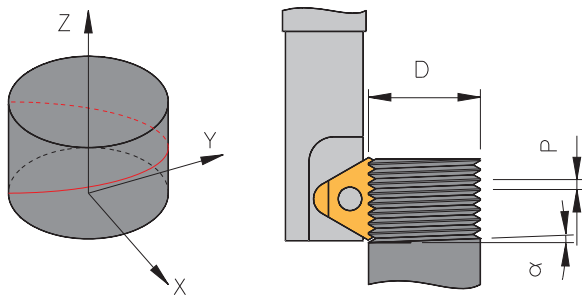

α = Steigungswinkel
Helix angle
Angolo d'elica

D = Gewinde-Außendurchmesser
Outside diameter
Diametro esterno

P = Steigung des Gewindes
Pitch
Passo

Zustellung

Für das Gewindefräsen wird in der Regel die Zustellung über einen tangierenden Kreisbogen empfohlen. Das Entstehen von Verweilmarken oder Vibrationen wird hierbei selbst bei härteren Werkstoffen vermieden.

Approach

The most common approach in thread milling is the so-called tangential arc approach. With this method, the tool enters and exits the workpiece smoothly. No marks are left on the workpiece and there is no vibration, even with harder materials.

Approccio

In interpolazione circolare l'approccio suggerito è lungo l'arco tangente. Altri metodi possono generare vibrazioni o rotture, specialmente su materiali più duri.

Außengewinde
External thread
Filettatura esterna

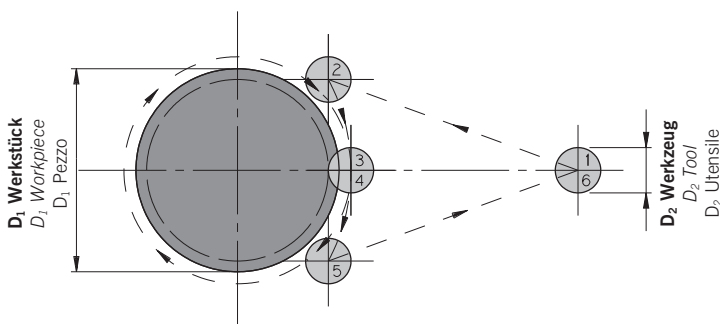

Innengewinde
Internal thread
Filettatura interna

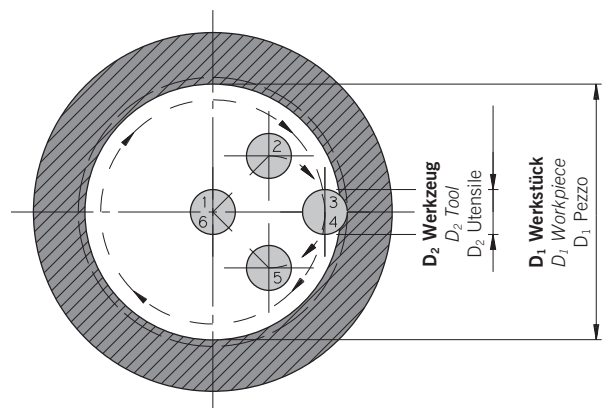

- 1 – 2 **Eilzustellung / rapid feed / Avanzamento rapido**
- 2 – 3 **Eintauchen über tangentialen Kreisbogen / helical entrance along arc / Entrata lungo arco tangente**
- 3 – 4 **schraubenförmige Bewegung um 360° / helical movement along arc of 360° / Percorso elicoidale lungo un arco di 360°**
- 4 – 5 **Werkzeugaustritt über tangentialen Bogen / helical exit along arc / Uscita elicoidale lungo arco tangente**
- 5 – 6 **Rückführung im Eilgang / rapid feed / Avanzamento rapido**

Wahl der Bearbeitungsmethode

Choice of machining method

Scelta del metodo

Die Wahl des Bearbeitungsverfahrens ist abhängig vom Werkstück und der zur Verfügung stehenden Maschine.

The choice of machining method depends on workpiece and machining center.

La scelta del metodo di lavorazione dipende anche dal tipo di particolare da lavorare e dalla macchina utensile.

Außen-Rechtsgewinde

External right-hand thread

Esterno – Filetto destro

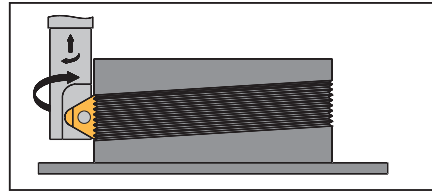

Gegenlaufräsen
Conventional milling
Fresatura discorde

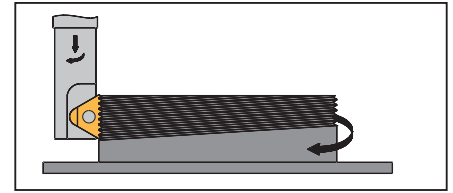

Gleichlaufräsen
Climb milling
Fresatura concorde

Außen-Linksgewinde

External left-hand thread

Esterno – Filetto sinistro

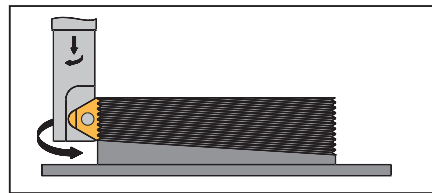

Gegenlaufräsen
Conventional milling
Fresatura discorde

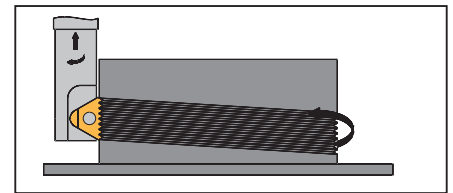

Gleichlaufräsen
Climb milling
Fresatura concorde

Innen-Rechtsgewinde

Internal right-hand thread

Interno – Filettatura destra

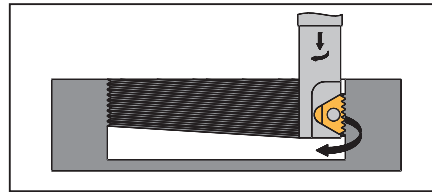

Gegenlaufräsen
Conventional milling
Fresatura discorde

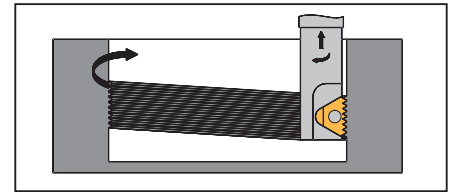

Gleichlaufräsen
Climb milling
Fresatura concorde

Innen-Linksgewinde

Internal left-hand thread

Interno – Filettatura sinistra

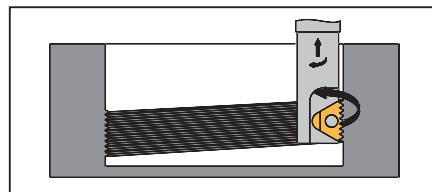

Gegenlaufräsen
Conventional milling
Fresatura discorde

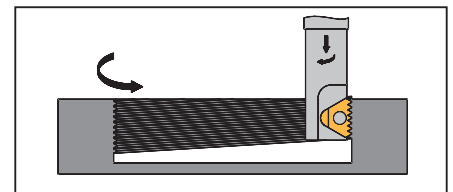

Gleichlaufräsen
Climb milling
Fresatura concorde

Information:

Zum Gewindefräsen sollte, wenn möglich, Gleichlaufräsen angewendet werden, um geringere Schnittkräfte, bessere Spanbildung, bessere Standzeit und Oberflächengüten zu erzielen.

Information:

When thread milling, generally climb milling should be preferred, in order to achieve lower cutting forces, better chip formation, better tool-life and surface finish.

Nota:

Per la fresatura di filetti, dove possibile utilizzare fresatura concorde per ridurre le forze di taglio ed ottimizzare lo spessore truciolo. Questo garantirà minori vibrazioni, maggior vita utensile e migliore finitura superficiale.

Set Drehmoment-Schraubendreher

Set Torque screwdriver

Set Manico dinamometrico

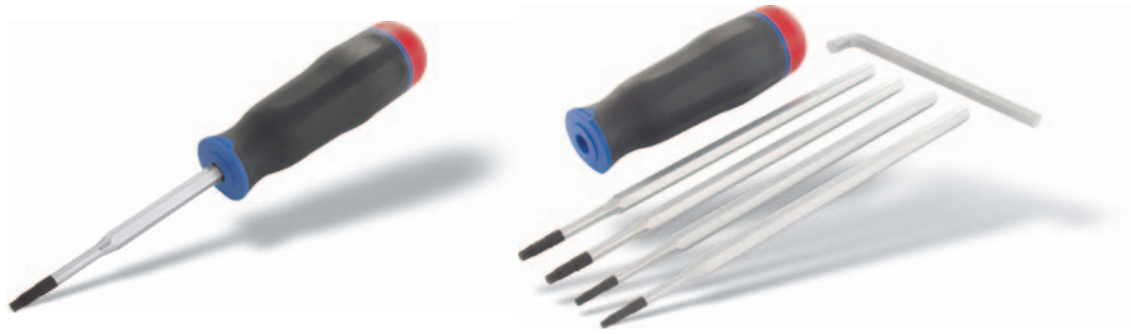

Set 1

Einstellbereich von 0,6 Nm–1,5 Nm

Adjustable from 0.6 Nm–1.5 Nm

Registabile da 0,6 Nm–1,5 Nm

- 1 Drehmoment-Schraubendreher
- je 1 Hochleistungsklinge Torx T6, Torx T7, Torx T8 und Torx T9
- 1 Einstellschlüssel

- 1 Torque screwdriver
- 1 each bits Torx T6, Torx T7, Torx T8 and Torx T9
- 1 Adjustment key

- 1 Manico dinamometrico
- 1 Set di chiavi per Torx T6, T7, T8, T9
- 1 chiave di registrazione

(Bestellbezeichnung: **Set-Drehmoment 1**)

(Ordering code: **Set-Torque 1**)

(Esempio di ordinazione: **Set-Drehmoment 1**)

Set 2

Einstellbereich von 1,5 Nm–3,0 Nm

Adjustable from 1.5 Nm–3.0 Nm

Registabile da 1,5 Nm–3,0 Nm

- 1 Drehmoment-Schraubendreher
- je 1 Hochleistungsklinge Torx T9, Torx T10 und Torx T15
- 1 Einstellschlüssel

- 1 Torque screwdriver
- 1 each bits Torx T9, Torx T10 and Torx T15
- 1 Adjustment key

- 1 Manico dinamometrico
- 1 Set di chiavi per Torx T9, T10, T15
- 1 chiave di registrazione

(Bestellbezeichnung: **Set-Drehmoment 2**)

(Ordering code: **Set-Torque 2**)

(Esempio di ordinazione: **Set-Drehmoment 2**)

Set 3

Einstellbereich von 3,0 Nm–5,4 Nm

Adjustable from 3.0 Nm–5.4 Nm

Registabile da 3,0 Nm–5,4 Nm

- 1 Drehmoment-Schraubendreher
- je 1 Hochleistungsklinge Torx T10, Torx T15 und Torx T20
- 1 Einstellschlüssel

- 1 Torque screwdriver
- 1 each bits Torx T10, Torx T15 and Torx T20
- 1 Adjustment key

- 1 Manico dinamometrico
- 1 Set di chiavi per Torx T10, T15, T20,
- 1 chiave di registrazione

(Bestellbezeichnung: **Set-Drehmoment 3**)

(Ordering code: **Set-Torque 3**)

(Esempio di ordinazione: **Set-Drehmoment 3**)

Zulässige Anzugsmomente für Wendeschneidplatten – Spannelemente /

Recommended torque settings for indexable inserts / Momenti di serraggio suggeriti per viti inserti

Gewinde Thread Vite	Torx-Größe Torx size Torx-Dimensione	max. Anzugsmoment max. torque Massimo momento torcente
M1,8	T6	0,6 Nm
M2	T6	0,6 Nm
M2	T7	0,6 Nm
M2,2	T6	1,0 Nm
M2,2	T7	1,0 Nm
M2,2	T8	1,3 Nm
M3	T8	2,2 Nm
M3	T9	2,2 Nm
M3,5	T15	3,4 Nm
M4	T15	5,1 Nm
M4,5	T20	6,2 Nm
M5	T20	6,2 Nm
M6	T25	8,1 Nm

Fräsen – Hartmetall

beschichtet

ISO	Werkstoff	Zugfestigkeit [N/mm ²]	Schnittgeschwindigkeit Vc [m/min]										
			AK2110	AK2120	AL136	AL160	AL260	AL360	AM2035	AM2110	AM2130	AM26C	
P	Unlegierter Stahl und Stahlguss	ca. 0,15 % C	350	220–380	110–260	100–250	–	120–200	110–180	180–230	–	–	100–210
		ca. 0,45 % C	650	190–330	90–150	80–150	–	90–140	90–130	170–190	–	–	80–170
		ca. 0,75 % C	1000	160–280	80–130	80–140	–	80–130	80–130	130–150	–	–	80–140
	Niedrig legierter Stahl und Stahlguss		600	180–300	170–290	–	–	60–120	–	170–190	–	–	100–170
			900	160–260	150–250	–	–	60–110	–	90–150	–	–	100–150
			1200	120–220	110–210	–	–	60–100	–	70–130	–	–	80–120
	Hochlegierter Stahl, hochlegierter Werkzeugstahl und Stahlguss	geglüht	700	140–220	130–210	90–180	–	80–120	80–120	120–200	–	–	70–130
		gehärtet und angelassen	1100	70–130	70–130	–	–	60–120	60–120	50–100	–	–	60–80
	Nichtrostender Stahl und Stahlguss	ferritisch/martensitisch, geglüht	700	140–220	140–210	100–190	–	110–200	100–180	140–180	–	–	90–130
		martensitisch, vergütet	1000	70–130	70–130	80–180	–	80–150	80–140	110–140	–	–	70–110
M	Nichtrostender Stahl und Stahlguss	austenitisch und	450–600	–	–	–	–	–	80–150	100–180	120–200	90–140	60–110
		austenitisch/ferritisch, abgeschreckt	600–900	–	–	–	–	80–140	80–140	70–140	70–180	–	60–120
K	Grauguss	perlitisch, ferritisch	500–700	250–380	250–350	–	160–340	130–310	–	–	–	–	–
		perlitisch, martensitisch	700–850	190–300	200–300	–	140–280	120–260	–	–	–	–	–
			800–1100	–	–	–	100–210	100–190	–	–	–	–	–
	Gusseisen mit Kugelgraphit	ferritisch	550	220–300	210–290	–	130–250	110–240	–	–	–	–	–
		perlitisch	800	150–230	150–220	–	100–200	100–190	–	–	–	–	–
	Temperguss	ferritisch	450	200–300	190–290	–	140–320	120–300	–	–	–	–	–
perlitisch		750	170–230	150–210	–	110–240	100–220	–	–	–	–	–	
N	Aluminium-Knetlegierungen	nicht aushärtbar	200	–	–	–	–	–	–	–	–	–	–
		aushärtbar, ausgehärtet	350	–	–	–	–	–	–	–	–	–	–
	Aluminium-Gusslegierungen	≤ 12 % Si, ausgehärtet	250	–	–	–	–	–	–	–	–	–	–
		≤ 12 % Si, aushärtbar, ausgehärtet	300	–	–	–	–	–	–	–	–	–	–
		≤ 12 % Si, nicht aushärtbar	450	–	–	–	–	–	–	–	–	–	–
	Kupfer und Kupferlegierungen (Bronze/ Messing)	Automatenlegierung, Pb > 1%	400	–	–	–	–	–	–	–	–	–	–
		Messing, Rotguss	300	–	–	–	–	–	–	–	–	–	–
		Aluminiumbronze	500	–	–	–	–	–	–	–	–	–	–
		Kupfer und Elektrolytkupfer	200	–	–	–	–	–	–	–	–	–	–
	Nichtmetallische Werkstoffe	Duroplaste		–	–	–	–	–	–	–	–	–	–
Faserverstärkte Kunststoffe			–	–	–	–	–	–	–	–	–	–	
Hartgummi			–	–	–	–	–	–	–	–	–	–	
S	Warmfeste Legierungen	Fe-Basis geglüht	700	–	–	–	–	–	–	20–40	–	–	–
		Fe-Basis ausgehärtet	950	–	–	–	–	–	–	15–35	–	–	–
		Ni- oder Co-Basis geglüht	800	–	–	–	–	–	–	8–25	–	–	–
		Ni- oder Co-Basis gegossen	1100	–	–	–	–	–	–	4–15	–	–	–
		Ni- oder Co-Basis ausgehärtet	1200	–	–	–	–	–	–	4–15	–	–	–
	Titanlegierungen	Rein-Titan	500–700	–	–	–	–	–	–	80–130	–	–	–
Alpha+Beta-Legierungen, ausgehärtet		700–1000	–	–	–	–	–	–	15–35	–	–	–	
H	Gehärteter Stahl	gehärtet und angelassen	1000–1350	–	–	–	–	–	–	–	–	–	
		gehärtet und angelassen	1350–1700	–	–	–	–	–	–	–	–	–	
	Hartguss	gegossen	1350	–	–	–	–	–	–	–	–	–	
Gehärtetes Gusseisen	gehärtet und angelassen	1900	–	–	–	–	–	–	–	–	–		

Die Tabellenwerte sind Richtwerte. Es kann notwendig sein, die Werte den jeweiligen Bearbeitungsbedingungen anzupassen.

Weitere Sorten finden Sie auf den folgenden Seiten. 

Fräsen – Hartmetall

beschichtet

ISO	Werkstoff	Zugfestigkeit [N/mm ²]	Schnittgeschwindigkeit Vc [m/min]										
			AM350	AM36C	AM5025	AM5040	AM5110	AM5120	AM5635	AP1530	AP2025	AP2035	
P	Unlegierter Stahl und Stahlguss	ca. 0,15 % C	350	150-220	100-250	180-230	120-200	220-350	220-320	150-260	170-250	190-240	180-230
		ca. 0,45 % C	650	120-150	100-200	170-190	80-150	180-310	180-290	150-260	140-200	170-200	170-190
		ca. 0,75 % C	1000	100-140	80-120	130-150	60-140	150-270	150-250	150-260	120-150	130-160	130-150
	Niedrig legierter Stahl und Stahlguss		600	90-150	80-140	170-190	80-160	180-300	180-260	80-220	110-150	170-200	170-190
			900	80-140	80-120	90-150	60-130	170-270	150-220	80-220	100-120	100-160	90-150
			1200	60-130	80-100	70-130	60-120	150-240	80-190	80-220	70-100	80-140	70-130
	Hochlegierter Stahl, hochlegierter Werkzeugstahl und Stahlguss	geglüht	700	110-200	60-120	120-200	80-140	80-180	80-150	90-180	90-130	130-170	120-200
		gehärtet und angelassen	1100	50-100	60-70	50-100	50-120	40-140	40-130	90-180	60-100	80-130	50-100
	Nichtrostender Stahl und Stahlguss	ferritisch/martensitisch, geglüht	700	100-170	80-140	140-180	60-160	40-180	40-150	70-180	120-170	130-180	140-180
		martensitisch, vergütet	1000	90-150	70-120	110-140	50-100	40-160	40-140	70-180	80-130	110-160	110-160
M	Nichtrostender Stahl und Stahlguss	austenitisch und	450-600	110-170	80-150	120-200	60-160	80-180	80-160	60-200	70-180	100-170	110-190
		austenitisch/ferritisch, abgeschreckt	600-900	80-150	-	90-160	50-100	40-140	40-130	60-200	60-130	-	80-150
K	Grauguss	perlitisch, ferritisch	500-700	-	-	120-160	-	180-350	180-300	-	-	130-200	-
		perlitisch, martensitisch	700-850	-	-	90-130	-	160-300	160-280	-	-	120-180	-
			800-1100	-	-	-	-	120-270	120-240	-	-	-	-
	Gusseisen mit Kugelgraphit	ferritisch	550	-	-	120-160	-	140-230	140-230	-	-	120-170	-
		perlitisch	800	-	-	120-180	-	120-170	120-170	-	-	120-190	-
	Temperguss	ferritisch	450	-	-	140-220	-	150-210	150-210	-	-	150-230	-
perlitisch		750	-	-	110-160	-	150-210	150-210	-	-	120-170	-	
N	Aluminium-Knetlegierungen	nicht aushärtbar	200	-	-	-	-	-	-	-	300-1000	-	-
		aushärtbar, ausgehärtet	350	-	-	-	-	-	-	-	300-700	-	-
	Aluminium-Gusslegierungen	≤ 12 % Si, ausgehärtet	250	-	-	-	-	-	-	-	300-700	-	-
		≤ 12 % Si, aushärtbar, ausgehärtet	300	-	-	-	-	-	-	-	300-500	-	-
		≤ 12 % Si, nicht aushärtbar	450	-	-	-	-	-	-	-	250-350	-	-
	Kupfer und Kupferlegierungen (Bronze/ Messing)	Automatenlegierung, Pb > 1%	400	-	-	-	-	200-650	200-500	-	400-500	-	-
		Messing, Rotguss	300	-	-	-	-	200-650	200-500	-	250-350	-	-
		Aluminiumbronze	500	-	-	-	-	160-350	160-300	-	300-500	-	-
		Kupfer und Elektrolytkupfer	200	-	-	-	-	120-220	120-200	-	250-400	-	-
	Nichtmetallische Werkstoffe	Duroplaste		-	-	-	-	160-600	160-600	-	-	-	-
Faserverstärkte Kunststoffe			-	-	-	-	100-300	100-300	-	-	-	-	
Hartgummi			-	-	-	-	-	-	-	-	-	-	
S	Warmfeste Legierungen	Fe-Basis geglüht	700	-	-	20-50	-	20-70	20-60	-	35-100	20-40	20-40
		Fe-Basis ausgehärtet	950	-	-	20-50	-	20-70	20-60	-	35-70	15-35	15-35
		Ni- oder Co-Basis geglüht	800	-	-	15-40	-	15-60	15-50	-	-	10-30	8-25
		Ni- oder Co-Basis gegossen	1100	-	-	10-25	-	15-50	15-40	-	20-60	5-18	4-15
		Ni- oder Co-Basis ausgehärtet	1200	-	-	20-35	-	15-50	15-40	-	40-60	5-18	4-15
	Titanlegierungen	Rein-Titan	500-700	-	-	80-140	-	100-210	90-180	-	40-60	80-130	80-130
Alpha+Beta-Legierungen, ausgehärtet		700-1000	-	-	25-45	-	40-90	40-80	-	-	20-40	15-35	
H	Gehärteter Stahl	gehärtet und angelassen	1000-1350	-	-	-	-	30-55	30-50	-	-	-	-
		gehärtet und angelassen	1350-1700	-	-	-	-	15-25	10-25	-	-	-	-
	Hartguss	gegossen	1350	-	-	-	-	40-80	40-70	-	-	-	-
Gehärtetes Gusseisen	gehärtet und angelassen	1900	-	-	-	-	15-30	10-25	-	-	-	-	

Die Tabellenwerte sind Richtwerte. Es kann notwendig sein, die Werte den jeweiligen Bearbeitungsbedingungen anzupassen.

Weitere Sorten finden Sie auf den folgenden Seiten. 

Fräsen – Hartmetall

beschichtet

ISO	Werkstoff	Zugfestigkeit [N/mm ²]	Schnittgeschwindigkeit Vc [m/min]											
			AP2110	AP2120	AP2125	AP2310	AP2320	AP2335	AP5020	AP5030	AP5635	AR16C	AR26C	
P	Unlegierter Stahl und Stahlguss	ca. 0,15 % C	350	300–400	250–350	130–350	300–400	250–350	180–270	120–220	120–220	100–220	–	100–280
		ca. 0,45 % C	650	260–350	210–300	110–320	260–350	210–300	170–230	80–150	80–150	100–220	–	100–220
		ca. 0,75 % C	1000	240–300	180–230	90–280	240–300	180–230	160–210	60–140	60–140	100–220	–	80–150
	Niedrig legierter Stahl und Stahlguss		600	220–300	180–270	100–280	220–300	180–270	160–220	80–170	80–170	80–200	–	100–200
			900	180–260	160–220	90–250	180–260	160–220	140–180	60–130	60–130	80–200	–	100–170
	Hochlegierter Stahl, hochlegierter Werkzeugstahl und Stahlguss	geglüht	700	150–220	130–200	80–190	150–220	130–200	130–180	80–140	80–140	80–200	–	70–140
		gehärtet und angelassen	1100	70–150	70–140	60–180	70–150	70–140	70–120	50–120	50–120	80–200	–	60–90
	Nichtrostender Stahl und Stahlguss	ferritisch/martensitisch, gegläht	700	–	–	80–190	–	–	–	60–170	60–170	70–180	–	90–130
		martensitisch, vergütet	1000	–	–	70–170	–	–	–	50–100	50–100	70–180	–	70–110
	M	Nichtrostender Stahl und Stahlguss	austenitisch und	450–600	–	–	110–200	–	–	–	60–180	60–170	60–200	–
austenitisch/ferritisch, abgeschreckt			600–900	–	–	120–210	–	–	–	50–100	50–100	60–200	–	–
K	Grauguss	perlitisch, ferritisch	500–700	160–230	–	120–220	–	–	–	–	–	–	150–350	–
		perlitisch, martensitisch	700–850	150–200	–	80–170	–	–	–	–	–	–	150–280	–
			800–1100	–	–	80–150	–	–	–	–	–	–	150–230	–
	Gusseisen mit Kugelgraphit	ferritisch	550	160–210	–	80–200	–	–	–	–	–	–	150–220	80–180
		perlitisch	800	130–170	–	70–180	–	–	–	–	–	–	150–180	80–160
	Temperguss	ferritisch	450	150–210	–	70–180	–	–	–	–	–	–	150–270	–
perlitisch		750	150–210	–	70–160	–	–	–	–	–	–	150–200	–	
N	Aluminium-Knetlegierungen	nicht aushärtbar	200	–	–	–	–	–	–	100–500	–	–	150–1200	–
		aushärtbar, ausgehärtet	350	–	–	–	–	–	–	100–300	–	–	150–800	–
	Aluminium-Gusslegierungen	≤ 12 % Si, ausgehärtet	250	–	–	–	–	–	–	100–500	–	–	150–900	–
		≤ 12 % Si, aushärtbar, ausgehärtet	300	–	–	–	–	–	–	100–300	–	–	150–600	–
		≤ 12 % Si, nicht aushärtbar	450	–	–	–	–	–	–	100–200	–	–	–	–
	Kupfer und Kupferlegierungen (Bronze/ Messing)	Automatenlegierung, Pb > 1%	400	–	–	–	–	–	–	100–500	–	–	150–600	–
		Messing, Rotguss	300	–	–	–	–	–	–	100–500	–	–	150–400	–
		Aluminiumbronze	500	–	–	–	–	–	–	100–300	–	–	–	–
		Kupfer und Elektrolytkupfer	200	–	–	–	–	–	–	100–300	–	–	150–300	–
	Nichtmetallische Werkstoffe	Duroplaste		–	–	–	–	–	–	80–180	–	–	–	–
Faserverstärkte Kunststoffe			–	–	–	–	–	–	60–150	–	–	–	–	
Hartgummi			–	–	–	–	–	–	100–220	–	–	–	–	
S	Warmfeste Legierungen	Fe-Basis gegläht	700	–	–	60–90	–	–	–	20–50	–	–	–	
		Fe-Basis ausgehärtet	950	–	–	60–90	–	–	–	20–40	–	–	–	
		Ni- oder Co-Basis gegläht	800	–	–	–	–	–	–	15–25	–	–	–	
		Ni- oder Co-Basis gegossen	1100	–	–	–	–	–	–	10–20	–	–	–	
		Ni- oder Co-Basis ausgehärtet	1200	–	–	–	–	–	–	10–20	–	–	–	
	Titanlegierungen	Rein-Titan	500–700	–	–	–	–	–	–	50–120	–	–	–	
Alpha+Beta-Legierungen, ausgehärtet		700–1000	–	–	–	–	–	–	30–50	–	–	–		
H	Gehärteter Stahl	gehärtet und angelassen	1000–1350	–	–	–	–	–	–	–	–	–	30–70	–
		gehärtet und angelassen	1350–1700	–	–	–	–	–	–	–	–	–	20–60	–
	Hartguss	gegossen	1350	–	–	–	–	–	–	–	–	–	–	
	Gehärtetes Gusseisen	gehärtet und angelassen	1900	–	–	–	–	–	–	–	–	–	–	

Die Tabellenwerte sind Richtwerte. Es kann notwendig sein, die Werte den jeweiligen Bearbeitungsumständen anzupassen.

Fräsen – Hartmetall

unbeschichtet

ISO	Werkstoff		Zugfestigkeit [N/mm ²]	Schnittgeschwindigkeit Vc [m/min]						
				AK05F	AK10F	AK20F	AP20F	AP40F	AK1010	AK1020
P	Unlegierter Stahl und Stahlguss	ca. 0,15 % C	350	-	-	-	90-150	90-140	-	-
		ca. 0,45 % C	650	-	-	-	90-120	90-100	-	-
		ca. 0,75 % C	1000	-	-	-	-	-	-	-
	Niedrig legierter Stahl und Stahlguss		600	-	-	-	-	-	-	-
			900	-	-	-	60-90	60-80	-	-
			1200	-	-	-	-	-	-	-
Hochlegierter Stahl, hochlegierter Werkzeugstahl und Stahlguss	geglüht	700	-	-	-	60-90	60-80	-	-	
	gehärtet und angelassen	1100	-	-	-	50-70	50-60	-	-	
Nichtrostender Stahl und Stahlguss	ferritisch/martensitisch, gegläht	700	-	-	-	80-100	80-100	-	-	
	martensitisch, vergütet	1000	-	-	-	80-100	80-100	-	-	
M	Nichtrostender Stahl und Stahlguss	austenitisch und	450-600	-	-	-	80-100	80-100	-	-
		austenitisch/ferritisch, abgeschreckt	600-900	-	-	-	80-100	80-100	-	-
K	Grauguss	perlitisch, ferritisch	500-700	90-160	90-150	90-150	-	-	120-160	120-160
		perlitisch, martensitisch	700-850	80-150	80-130	80-130	-	-	90-140	90-140
			800-1100	100-140	80-130	80-130	-	-	80-140	80-140
	Gusseisen mit Kugelgraphit	ferritisch	550	90-160	90-150	90-150	-	-	130-170	130-170
		perlitisch	800	100-150	80-140	80-140	-	-	90-130	90-130
	Temperguss	ferritisch	450	90-150	90-150	90-150	-	-	140-200	140-200
perlitisch		750	80-140	80-150	80-150	-	-	120-160	120-160	
N	Aluminium-Knetlegierungen	nicht aushärtbar	200	200-2500	200-3000	200-3000	-	-	300-2500	300-2500
		aushärtbar, ausgehärtet	350	200-1800	200-3000	200-3000	-	-	200-2000	200-2000
	Aluminium-Gusslegierungen	≤ 12 % Si, ausgehärtet	250	200-1800	200-2000	200-2000	-	-	400-1500	400-1500
		≤ 12 % Si, aushärtbar, ausgehärtet	300	200-1500	200-1800	200-1800	-	-	400-1500	400-1500
		≤ 12 % Si, nicht aushärtbar	450	200-800	200-1000	200-1000	-	-	200-800	200-800
	Kupfer und Kupferlegierungen (Bronze/ Messing)	Automatenlegierung, Pb > 1%	400	200-600	200-600	200-600	-	-	250-600	250-600
		Messing, Rotguss	300	220-800	250-1000	250-1000	-	-	200-600	200-600
		Aluminiumbronze	500	-	100-400	100-400	-	-	150-400	150-400
		Kupfer und Elektrolytkupfer	200	250-700	200-800	200-800	-	-	150-300	150-300
	Nichtmetallische Werkstoffe	Duroplaste		100-700	-	-	-	-	80-180	80-180
Faserverstärkte Kunststoffe			70-350	-	-	-	-	60-150	60-150	
Hartgummi			80-280	-	-	-	-	100-250	100-250	
S	Warmfeste Legierungen	Fe-Basis gegläht	700	-	-	-	-	-	15-40	-
		Fe-Basis ausgehärtet	950	-	-	-	-	-	8-28	-
		Ni- oder Co-Basis gegläht	800	-	-	-	-	-	10-30	-
		Ni- oder Co-Basis gegossen	1100	-	-	-	-	-	8-25	-
		Ni- oder Co-Basis ausgehärtet	1200	-	-	-	-	-	8-25	-
	Titanlegierungen	Rein-Titan	500-700	-	-	-	-	-	60-120	60-120
Alpha+ Beta-Legierungen, ausgehärtet		700-1000	-	-	-	-	-	30-80	30-80	
H	Gehärteter Stahl	gehärtet und angelassen	1000-1350	-	30-40	30-40	-	-	-	-
		gehärtet und angelassen	1350-1700	-	25-35	25-35	-	-	-	-
	Hartguss	gegossen	1350	-	-	-	-	-	-	-
Gehärtetes Gusseisen	gehärtet und angelassen	1900	-	-	-	-	-	-	-	

Die Tabellenwerte sind Richtwerte. Es kann notwendig sein, die Werte den jeweiligen Bearbeitungsumständen anzupassen.

Fräsen – Hochpositive Wendeschneidplatten

beschichtet

ISO	Werkstoff	Zugfestigkeit [N/mm ²]	Schnittgeschwindigkeit Vc [m/min]							
			AM15C	AM5015	AM5020	AM5025	AM5110	AM5120+	AP5210	
P	Unlegierter Stahl und Stahlguss	ca. 0,15 % C	350	220–320	220–320	200–260	180–230	220–350	180–280	220–370
		ca. 0,45 % C	650	180–250	180–290	170–240	170–190	180–310	160–250	180–330
		ca. 0,75 % C	1000	140–200	150–250	140–200	130–150	150–270	120–220	150–290
	Niedrig legierter Stahl und Stahlguss		600	180–250	180–280	170–240	170–190	180–300	–	180–320
			900	160–220	170–250	150–200	90–150	170–270	–	170–290
			1200	140–200	150–220	130–190	70–130	150–240	–	150–260
	Hochlegierter Stahl, hochlegierter Werkzeugstahl und Stahlguss	geglüht	700	140–230	80–160	70–140	120–200	80–180	–	80–180
		gehärtet und angelassen	1100	110–200	40–130	40–130	50–100	40–140	–	40–150
	Nichtrostender Stahl und Stahlguss	ferritisch/martensitisch, geglüht	700	170–260	60–180	50–160	140–180	40–180	50–160	40–140
		martensitisch, vergütet	1000	110–200	40–140	40–140	110–140	40–160	40–140	40–120
M	Nichtrostender Stahl und Stahlguss	austenitisch und	450–600	210–250	80–160	70–150	120–200	80–180	70–150	70–150
		austenitisch/ferritisch, abgeschreckt	600–900	100–170	40–130	40–120	90–160	40–140	35–120	35–120
K	Grauguss	perlitisch, ferritisch	500–700	210–250	180–300	160–280	120–160	180–350	180–300	180–350
		perlitisch, martensitisch	700–850	90–130	160–280	140–260	90–130	160–300	160–280	160–300
			800–1100	90–130	120–240	120–220	–	120–270	120–240	120–270
	Gusseisen mit Kugelgraphit	ferritisch	550	210–250	140–230	130–200	120–160	140–230	–	140–230
		perlitisch	800	90–130	120–170	110–160	120–180	120–170	–	120–170
Temperguss	ferritisch	450	210–250	150–210	140–200	140–220	150–210	–	150–210	
	perlitisch	750	90–130	150–210	140–200	110–160	150–210	–	150–210	
N	Aluminium-Knetlegierungen	nicht aushärtbar	200	–	–	–	–	–	–	–
		aushärtbar, ausgehärtet	350	–	–	–	–	–	–	–
	Aluminium-Gusslegierungen	≤ 12 % Si, ausgehärtet	250	–	–	–	–	–	–	–
		≤ 12 % Si, aushärtbar, ausgehärtet	300	–	–	–	–	–	–	–
		≤ 12 % Si, nicht aushärtbar	450	–	–	–	–	–	–	–
	Kupfer und Kupferlegierungen (Bronze/ Messing)	Automatenlegierung, Pb > 1%	400	–	200–500	200–500	–	200–650	150–500	–
		Messing, Rotguss	300	–	200–500	200–500	–	200–650	150–500	–
		Aluminiumbronze	500	–	160–450	160–450	–	160–350	120–400	–
		Kupfer und Elektrolytkupfer	200	–	100–320	100–320	–	120–220	120–250	–
	Nichtmetallische Werkstoffe	Duroplaste		–	160–600	160–600	–	160–600	–	–
Faserverstärkte Kunststoffe			–	100–300	100–300	–	100–300	100–300	–	
Hartgummi			–	–	–	–	–	–	–	
S	Warmfeste Legierungen	Fe-Basis geglüht	700	–	20–60	20–60	20–50	20–70	20–60	20–70
		Fe-Basis ausgehärtet	950	–	20–60	20–60	20–50	20–70	20–60	20–70
		Ni- oder Co-Basis geglüht	800	–	15–50	15–50	15–40	15–60	15–50	15–60
		Ni- oder Co-Basis gegossen	1100	–	15–40	15–40	10–25	15–50	15–40	15–50
		Ni- oder Co-Basis ausgehärtet	1200	–	15–40	15–40	20–35	15–50	15–40	15–50
	Titanlegierungen	Rein-Titan	500–700	–	90–180	90–180	80–140	100–210	–	–
Alpha+ Beta-Legierungen, ausgehärtet		700–1000	–	40–80	40–80	25–45	40–90	–	–	
H	Gehärteter Stahl	gehärtet und angelassen	1000–1350	–	30–50	30–50	–	30–55	–	–
		gehärtet und angelassen	1350–1700	–	10–25	10–25	–	15–25	–	–
	Hartguss	gegossen	1350	–	40–70	40–70	–	40–80	–	–
Gehärtetes Gusseisen	gehärtet und angelassen	1900	–	10–25	10–25	–	15–30	–	–	

Die Tabellenwerte sind Richtwerte. Es kann notwendig sein, die Werte den jeweiligen Bearbeitungsumständen anzupassen.

Weitere Sorten finden Sie auf den folgenden Seiten.

Fräsen – Hochpositive Wendeschneidplatten

beschichtet

ISO	Werkstoff	Zugfestigkeit [N/mm ²]	Schnittgeschwindigkeit Vc [m/min]							
			AL10	AL20	AT10	AT20	PVD1	PVD2	AD2	
P	Unlegierter Stahl und Stahlguss	ca. 0,15 % C	350	220–320	180–280	220–320	180–280	200–290	160–250	–
		ca. 0,45 % C	650	180–290	160–250	180–290	160–250	160–260	140–220	–
		ca. 0,75 % C	1000	150–250	120–220	150–250	120–220	130–230	110–180	–
	Niedrig legierter Stahl und Stahlguss		600	180–280	160–250	180–280	160–250	160–250	140–220	–
			900	170–250	140–230	170–250	140–230	150–230	130–200	–
			1200	150–220	120–200	150–220	120–200	130–200	110–190	–
	Hochlegierter Stahl, hochlegierter Werkzeugstahl und Stahlguss	geglüht	700	–	–	–	–	–	–	–
gehärtet und angelassen		1100	–	–	–	–	–	–	–	
Nichtrostender Stahl und Stahlguss	ferritisch/martensitisch, geglüht	700	170–290	160–280	170–290	160–280	150–260	130–220	–	
	martensitisch, vergütet	1000	140–280	130–280	140–280	130–280	120–250	110–200	–	
M	Nichtrostender Stahl und Stahlguss	austenitisch und austenitisch/ferritisch, abgeschreckt	450–600	140–280	140–240	140–280	140–240	120–250	120–200	–
			600–900	–	–	–	–	–	–	–
K	Grauguss	perlitisch, ferritisch	500–700	180–300	160–270	180–300	160–270	160–270	–	–
		perlitisch, martensitisch	700–850	160–280	140–250	160–280	140–250	140–250	–	–
			800–1100	120–240	110–220	120–240	110–220	110–220	–	–
	Gusseisen mit Kugelgraphit	ferritisch	550	140–230	130–210	140–230	130–210	120–210	–	–
		perlitisch	800	120–170	110–150	120–170	110–150	110–150	–	–
Temperguss	ferritisch	450	150–210	130–200	150–210	130–200	130–180	–	–	
	perlitisch	750	150–210	130–200	150–210	130–200	130–180	–	–	
N	Aluminium-Knetlegierungen	nicht aushärtbar	200	–	–	850–1300	850–1300	750–1200	750–1200	650–2000
		aushärtbar, ausgehärtet	350	–	–	400–900	400–900	350–800	350–800	300–2000
	Aluminium-Gusslegierungen	≤ 12 % Si, ausgehärtet	250	–	–	260–800	260–800	230–700	230–700	650–2000
		≤ 12 % Si, aushärtbar, ausgehärtet	300	–	–	200–550	200–550	180–500	180–500	300–2000
		≤ 12 % Si, nicht aushärtbar	450	–	–	200–500	200–500	180–450	180–450	200–2000
	Kupfer und Kupferlegierungen (Bronze/ Messing)	Automatenlegierung, Pb > 1%	400	–	–	–	–	–	–	250–800
		Messing, Rotguss	300	–	–	–	–	–	–	250–800
Aluminiumbronze		500	–	–	–	–	–	–	250–800	
Kupfer und Elektrolytkupfer		200	–	–	–	–	–	–	130–400	
Nichtmetallische Werkstoffe	Duroplaste		–	–	–	–	–	–	–	
	Faserverstärkte Kunststoffe		–	–	–	–	–	–	–	
	Hartgummi		–	–	–	–	–	–	–	
S	Warmfeste Legierungen	Fe-Basis geglüht	700	20–50	20–50	20–50	20–50	15–45	15–45	–
		Fe-Basis ausgehärtet	950	20–50	20–50	20–50	20–50	15–45	15–45	–
		Ni- oder Co-Basis geglüht	800	15–40	15–40	15–40	15–40	10–35	10–35	–
		Ni- oder Co-Basis gegossen	1100	15–30	15–30	15–30	15–30	10–25	10–25	–
		Ni- oder Co-Basis ausgehärtet	1200	15–30	15–30	15–30	15–30	10–25	10–25	–
Titanlegierungen	Rein-Titan	500–700	–	–	–	–	–	–	–	
Alpha+ Beta-Legierungen, ausgehärtet		700–1000	–	–	–	–	–	–	–	
H	Gehärteter Stahl	gehärtet und angelassen	1000–1350	–	–	–	–	–	–	–
		gehärtet und angelassen	1350–1700	–	–	–	–	–	–	–
	Hartguss	gegossen	1350	–	–	–	–	–	–	–
Gehärtetes Gusseisen	gehärtet und angelassen	1900	–	–	–	–	–	–	–	

Die Tabellenwerte sind Richtwerte. Es kann notwendig sein, die Werte den jeweiligen Bearbeitungsumständen anzupassen.

Fräsen – Hochpositive Wendeschneidplatten

unbeschichtet

ISO	Werkstoff		Zugfestigkeit [N/mm ²]	Schnittgeschwindigkeit Vc [m/min]			
				AK10	AK20	AK10F	AK20F
P	Unlegierter Stahl und Stahlguss	ca. 0,15 % C	350	-	-	-	-
		ca. 0,45 % C	650	-	-	-	-
		ca. 0,75 % C	1000	-	-	-	-
	Niedrig legierter Stahl und Stahlguss		600	-	-	-	-
			900	-	-	-	-
			1200	-	-	-	-
Hochlegierter Stahl, hochlegierter Werkzeugstahl und Stahlguss	geglüht	700	-	-	-	-	
	gehärtet und angelassen	1100	-	-	-	-	
Nichtrostender Stahl und Stahlguss	ferritisch/martensitisch, gegläht	700	-	-	-	-	
	martensitisch, vergütet	1000	-	-	-	-	
M	Nichtrostender Stahl und Stahlguss	austenitisch und	450-600	-	-	-	-
		austenitisch/ferritisch, abgeschreckt	600-900	-	-	-	-
K	Grauguss	perlitisch, ferritisch	500-700	120-160	120-160	90-150	90-150
		perlitisch, martensitisch	700-850	90-140	90-140	80-130	80-130
			800-1100	80-140	80-140	80-130	80-130
	Gusseisen mit Kugelgraphit	ferritisch	550	130-170	130-170	90-150	90-150
		perlitisch	800	90-130	90-130	80-140	80-140
	Temperguss	ferritisch	450	140-200	140-200	90-150	90-150
perlitisch		750	120-160	120-160	80-150	80-150	
N	Aluminium-Knetlegierungen	nicht aushärtbar	200	300-2500	300-2500	200-3000	200-3000
		aushärtbar, ausgehärtet	350	200-2000	200-2000	200-3000	200-3000
	Aluminium-Gusslegierungen	≤ 12 % Si, ausgehärtet	250	400-1500	400-1500	200-2000	200-2000
		≤ 12 % Si, aushärtbar, ausgehärtet	300	400-1500	400-1500	200-1800	200-1800
		≤ 12 % Si, nicht aushärtbar	450	200-800	200-800	200-1000	200-1000
	Kupfer und Kupferlegierungen (Bronze/ Messing)	Automatenlegierung, Pb > 1%	400	250-600	250-600	200-600	200-600
Messing, Rotguss		300	200-600	200-600	250-1000	250-1000	
Aluminiumbronze		500	150-400	150-400	100-400	100-400	
Kupfer und Elektrolytkupfer		200	150-300	150-300	200-800	200-800	
Nichtmetallische Werkstoffe	Duroplaste		80-180	80-180	-	-	
	Faserverstärkte Kunststoffe		60-150	60-150	-	-	
	Hartgummi		100-250	100-250	-	-	
S	Warmfeste Legierungen	Fe-Basis gegläht	700	15-40	-	-	-
		Fe-Basis ausgehärtet	950	8-28	-	-	-
		Ni- oder Co-Basis gegläht	800	10-30	-	-	-
		Ni- oder Co-Basis gegossen	1100	8-25	-	-	-
		Ni- oder Co-Basis ausgehärtet	1200	8-25	-	-	-
	Titanlegierungen	Rein-Titan	500-700	60-120	-	-	-
Alpha+ Beta-Legierungen, ausgehärtet		700-1000	30-80	30-80	-	-	
H	Gehärteter Stahl	gehärtet und angelassen	1000-1350	-	-	30-40	30-40
		gehärtet und angelassen	1350-1700	-	-	25-35	25-35
	Hartguss	gegossen	1350	-	-	-	-
Gehärtetes Gusseisen	gehärtet und angelassen	1900	-	-	-	-	

Die Tabellenwerte sind Richtwerte. Es kann notwendig sein, die Werte den jeweiligen Bearbeitungsumständen anzupassen.

Fräsen – CERMET/Hochharte Schneidstoffe/HSS-Schneidstoff

ISO	Werkstoff	Zugfestigkeit [N/mm ²]	Schnittgeschwindigkeit Vc [m/min]										
			AP6510	AC90C	AP6010	ACE6	AH7510	AH7516	AH7520	AB8020	HSS-TiN	HSS-TiAlN	
P	Unlegierter Stahl und Stahlguss	ca. 0,15 % C	350	100-500	160-460	100-450	100-400	-	-	-	-	70-100	80-110
		ca. 0,45 % C	650	80-500	90-430	80-450	80-370	-	-	-	-	65-90	70-100
		ca. 0,75 % C	1000	50-350	60-400	50-350	50-350	-	-	-	-	35-55	30-60
	Niedrig legierter Stahl und Stahlguss		600	80-500	90-350	80-450	80-300	-	-	-	-	30-80	35-90
			900	70-500	80-300	70-450	70-270	-	-	-	-	30-80	35-90
		1200	50-350	60-300	50-350	50-250	-	-	-	-	30-60	35-70	
Hochlegierter Stahl, hochlegierter Werkzeugstahl und Stahlguss	geglüht	700	60-320	90-230	60-250	80-200	-	-	-	-	30-60	35-70	
	gehärtet und angelassen	1100	50-180	60-180	50-180	50-160	-	-	-	-	-	-	
Nichtrostender Stahl und Stahlguss	ferritisch/martensitisch, geglüht	700	80-350	90-290	80-300	80-250	-	-	-	-	20-35	20-40	
	martensitisch, vergütet	1000	80-400	-	80-350	80-250	-	-	-	-	-	-	
M	Nichtrostender Stahl und Stahlguss	austenitisch und	450-600	80-380	-	80-300	80-240	-	-	-	-	20-35	20-40
		austenitisch/ferritisch, abgeschreckt	600-900	60-350	-	60-300	80-240	-	-	-	-	-	-
K	Grauguss	perlitisch, ferritisch	500-700	100-500	-	100-300	80-300	700-2000	-	-	-	-	-
		perlitisch, martensitisch	700-850	100-380	-	100-300	80-260	500-900	-	-	-	-	-
			800-1100	100-350	-	100-300	80-240	-	-	-	-	-	-
	Gusseisen mit Kugelgraphit	ferritisch	550	80-350	80-300	100-300	80-300	-	-	-	-	-	-
		perlitisch	800	80-350	80-250	100-300	80-250	-	-	-	-	-	-
	Temperguss	ferritisch	450	80-350	80-350	100-300	80-350	-	-	-	-	-	-
perlitisch		750	80-350	60-250	100-300	60-250	-	-	-	-	-	-	
N	Aluminium-Knetlegierungen	nicht aushärtbar	200	-	-	-	-	-	-	-	400-2500	400-900	400-900
		aushärtbar, ausgehärtet	350	-	-	-	-	-	-	-	300-2500	140-240	150-250
	Aluminium-Gusslegierungen	≤ 12 % Si, ausgehärtet	250	-	-	-	-	-	-	-	400-2000	140-240	150-250
		≤ 12 % Si, aushärtbar, ausgehärtet	300	-	-	-	-	-	-	-	400-2000	140-240	150-250
		≤ 12 % Si, nicht aushärtbar	450	-	-	-	-	-	-	-	400-1800	60-130	70-140
	Kupfer und Kupferlegierungen (Bronze/ Messing)	Automatenlegierung, Pb > 1%	400	-	-	-	-	-	-	-	300-1800	90-110	100-120
Messing, Rotguss		300	-	-	-	-	-	-	-	400-1600	-	-	
Aluminiumbronze		500	-	-	-	-	-	-	-	300-1800	-	-	
Kupfer und Elektrolytkupfer		200	-	-	-	-	-	-	-	300-1800	110-180	120-200	
Nichtmetallische Werkstoffe	Duroplaste		-	-	-	-	-	-	-	-	80-140	90-150	
	Faserverstärkte Kunststoffe		-	-	-	-	-	-	-	200-900	-	-	
	Hartgummi		-	-	-	-	-	-	-	-	-	-	
S	Warmfeste Legierungen	Fe-Basis geglüht	700	-	-	-	-	300-500	-	-	-	10-20	10-25
		Fe-Basis ausgehärtet	950	-	-	-	-	250-350	-	-	-	10-20	10-25
		Ni- oder Co-Basis geglüht	800	-	-	-	-	280-400	-	-	-	10-20	10-25
		Ni- oder Co-Basis gegossen	1100	-	-	-	-	200-300	-	-	-	-	-
		Ni- oder Co-Basis ausgehärtet	1200	-	-	-	-	200-300	-	-	-	-	-
	Titanlegierungen	Rein-Titan	500-700	-	-	-	-	-	-	-	100-400	15-30	15-35
Alpha+ Beta-Legierungen, ausgehärtet		700-1000	-	-	-	-	-	-	-	100-350	15-30	15-35	
H	Gehärteter Stahl	gehärtet und angelassen	1000-1350	-	-	-	-	-	120-250	80-180	-	-	-
		gehärtet und angelassen	1350-1700	-	-	-	-	-	-	50-150	-	-	-
	Hartguss	gegossen	1350	-	-	-	-	60-150	-	-	-	-	-
Gehärtetes Gusseisen	gehärtet und angelassen	1900	-	-	-	-	50-150	-	-	-	-	-	

Die Tabellenwerte sind Richtwerte. Es kann notwendig sein, die Werte den jeweiligen Bearbeitungsumständen anzupassen.

Gewindefräsen

ISO	Werkstoff	Zugfestigkeit [N/mm ²]	Schnittgeschwindigkeit Vc [m/min]			
			AL100	AM15C	AK20(P)	
P	Unlegierter Stahl und Stahlguss	ca. 0,15 % C	350	115 – 190	140 – 200	-
		ca. 0,45 % C	650	100 – 190	130 – 180	-
		ca. 0,75 % C	1000	70 – 160	80 – 160	-
	Niedrig legierter Stahl und Stahlguss		600	85 – 145	100 – 155	-
			900	75 – 140	90 – 145	-
			1200	70 – 135	80 – 135	-
	Hochlegierter Stahl, hochlegierter Werkzeugstahl und Stahlguss	geglüht	700	70 – 110	70 – 115	-
gehärtet und angelassen		1100	50 – 100	50 – 100	-	
Nichtrostender Stahl und Stahlguss	ferritisch/martensitisch, gegläht	700	75 – 140	-	-	
	martensitisch, vergütet	1000	60 – 120	-	-	
M	Nichtrostender Stahl und Stahlguss	austenitisch und	450 – 600	70 – 130	70 – 120	-
		austenitisch/ferritisch, abgeschreckt	600 – 900	40 – 110	40 – 90	-
K	Grauguss	perlitisch, ferritisch	500 – 700	70 – 130	-	-
		perlitisch, martensitisch	700 – 850	60 – 120	-	-
			800 – 1100	60 – 115	-	-
	Gusseisen mit Kugelgraphit	ferritisch	550	125 – 160	-	-
		perlitisch	800	90 – 120	-	-
Temperguss	ferritisch	450	80 – 180	70 – 150	70 – 95	
	perlitisch	750	-	-	-	
N	Aluminium-Knetlegierungen	nicht aushärtbar	200	100 – 365	100 – 240	100 – 250
		aushärtbar, ausgehärtet	350	80 – 220	80 – 170	80 – 160
	Aluminium-Gusslegierungen	≤ 12 % Si, ausgehärtet	250	200 – 400	-	80 – 120
		≤ 12 % Si, aushärtbar, ausgehärtet	300	200 – 280	-	70 – 100
		≤ 12 % Si, nicht aushärtbar	450	60 – 180	-	50 – 120
	Kupfer und Kupferlegierungen (Bronze/ Messing)	Automatenlegierung, Pb > 1%	400	80 – 200	100 – 250	110 – 190
		Messing, Rotguss	300	80 – 225	80 – 200	70 – 170
Aluminiumbronze		500	-	-	-	
Kupfer und Elektrolytkupfer		200	120 – 240	100 – 250	110 – 190	
Nichtmetallische Werkstoffe	Duroplaste		-	-	-	
	Faserverstärkte Kunststoffe		-	-	-	
	Hartgummi		-	-	-	
S	Warmfeste Legierungen	Fe-Basis gegläht	700	45 – 60	-	30 – 50
		Fe-Basis ausgehärtet	950	30 – 50	-	25 – 40
		Ni- oder Co-Basis gegläht	800	20 – 30	-	20 – 30
		Ni- oder Co-Basis gegossen	1100	-	-	-
		Ni- oder Co-Basis ausgehärtet	1200	15 – 25	-	15 – 25
	Titanlegierungen	Rein-Titan	500 – 700	140 – 170	-	60 – 100
Alpha+ Beta-Legierungen, ausgehärtet		700 – 1000	50 – 70	-	40 – 60	
H	Gehärteter Stahl	gehärtet und angelassen	1000 – 1350	-	-	-
		gehärtet und angelassen	1350 – 1700	-	-	-
	Hartguss	gegossen	1350	-	-	-
Gehärtetes Gusseisen	gehärtet und angelassen	1900	45 – 60	45 – 60	-	

Die Tabellenwerte sind Richtwerte. Es kann notwendig sein, die Werte den jeweiligen Bearbeitungsumständen anzupassen.

Milling – Carbide

coated

ISO	Material	Tensile strength [N/mm ²]	Cutting speed Vc [m/min]										
			AK2110	AK2120	AL136	AL160	AL260	AL360	AM2035	AM2110	AM2130	AM26C	
P	Unalloyed steel and cast steel	ca. 0,15 % C	350	220-380	110-260	100-250	-	120-200	110-180	180-230	-	-	100-210
		ca. 0,45 % C	650	190-330	90-150	80-150	-	90-140	90-130	170-190	-	-	80-170
		ca. 0,75 % C	1000	160-280	80-130	80-140	-	80-130	80-130	130-150	-	-	80-140
	Low alloyed steel and cast steel		600	180-300	170-290	-	-	60-120	-	170-190	-	-	100-170
			900	160-260	150-250	-	-	60-110	-	90-150	-	-	100-150
			1200	120-220	110-210	-	-	60-100	-	70-130	-	-	80-120
	High alloyed steel, high alloyed tool steel and cast steel	annealed	700	140-220	130-210	90-180	-	80-120	80-120	120-200	-	-	70-130
		hardened and tempered	1100	70-130	70-130	-	-	60-120	60-120	50-100	-	-	60-80
	Stainless steel and cast steel	ferritic/martensitic, annealed	700	140-220	140-210	100-190	-	110-200	100-180	140-180	-	-	90-130
martensitic, hardened and tempered		1000	70-130	70-130	80-180	-	80-150	80-140	110-140	-	-	70-110	
M	Stainless steel and cast steel	austenitic and austenitic/ferritic	450-600	-	-	-	-	-	80-150	100-180	120-200	90-140	60-110
		chilled	600-900	-	-	-	-	80-140	80-140	70-140	70-180	-	60-120
K	Cast iron	pearlitic, ferritic	500-700	250-380	250-350	-	160-340	130-310	-	-	-	-	-
		pearlitic, martensitic	700-850	190-300	200-300	-	140-280	120-260	-	-	-	-	-
			800-1100	-	-	-	100-210	100-190	-	-	-	-	-
	Cast iron with nodular graphite	ferritic	550	220-300	210-290	-	130-250	110-240	-	-	-	-	-
		pearlitic	800	150-230	150-220	-	100-200	100-190	-	-	-	-	-
	Malleable cast iron	ferritic	450	200-300	190-290	-	140-320	120-300	-	-	-	-	-
pearlitic		750	170-230	150-210	-	110-240	100-220	-	-	-	-	-	
N	Aluminum alloys, long chipping	not heat treatable	200	-	-	-	-	-	-	-	-	-	-
		heat treatable, heat treated	350	-	-	-	-	-	-	-	-	-	-
	Casted aluminum alloys	≤ 12 % Si, hardened	250	-	-	-	-	-	-	-	-	-	-
		≤ 12 % Si, heat treatable, hardened	300	-	-	-	-	-	-	-	-	-	-
		≤ 12 % Si, not heat treatable	450	-	-	-	-	-	-	-	-	-	-
	Copper and copper alloys (brass/bronze)	Lead alloys, Pb > 1%	400	-	-	-	-	-	-	-	-	-	-
		Brass, bronze	300	-	-	-	-	-	-	-	-	-	-
		Aluminum bronze	500	-	-	-	-	-	-	-	-	-	-
		Copper and electrolyte copper	200	-	-	-	-	-	-	-	-	-	-
Non-ferrous materials	Duroplastics		-	-	-	-	-	-	-	-	-	-	
	Reinforced plastics		-	-	-	-	-	-	-	-	-	-	
	Hard rubber		-	-	-	-	-	-	-	-	-	-	
S	High temperature resistant alloys	Fe-alloyed annealed	700	-	-	-	-	-	20-40	-	-	-	
		Fe-alloyed hardened	950	-	-	-	-	-	15-35	-	-	-	
		Ni- oder Co- based annealed	800	-	-	-	-	-	8-25	-	-	-	
		Ni- oder Co- based casting	1100	-	-	-	-	-	4-15	-	-	-	
		Ni- oder Co- based hardened	1200	-	-	-	-	-	4-15	-	-	-	
	Titanium alloys, high strength	Pure titanium	500-700	-	-	-	-	-	80-130	-	-	-	
Alpha- and beta-alloys, hardened		700-1000	-	-	-	-	-	15-35	-	-	-		
H	Hardened steel	hardened and tempered	1000-1350	-	-	-	-	-	-	-	-	-	
		hardened and tempered	1350-1700	-	-	-	-	-	-	-	-	-	
	Hard cast iron	casting	1350	-	-	-	-	-	-	-	-	-	
Hardened cast iron	hardened and tempered	1900	-	-	-	-	-	-	-	-	-		

The data cutting speeds given are approximate values.
It is necessary to adjust them to the individual machining operation.

More grades on the following pages. 

Milling – Carbide

coated

ISO	Material	Tensile strength [N/mm ²]	Cutting speed Vc [m/min]										
			AM350	AM36C	AM5025	AM5040	AM5110	AM5120	AM5635	AP1530	AP2025	AP2035	
P	Unalloyed steel and cast steel	ca. 0,15 % C	350	150-220	100-250	180-230	120-200	220-350	220-320	150-260	170-250	190-240	180-230
		ca. 0,45 % C	650	120-150	100-200	170-190	80-150	180-310	180-290	150-260	140-200	170-200	170-190
		ca. 0,75 % C	1000	100-140	80-120	130-150	60-140	150-270	150-250	150-260	120-150	130-160	130-150
	Low alloyed steel and cast steel		600	90-150	80-140	170-190	80-160	180-300	180-260	80-220	110-150	170-200	170-190
			900	80-140	80-120	90-150	60-130	170-270	150-220	80-220	100-120	100-160	90-150
			1200	60-130	80-100	70-130	60-120	150-240	80-190	80-220	70-100	80-140	70-130
	High alloyed steel, high alloyed tool steel and cast steel	annealed	700	110-200	60-120	120-200	80-140	80-180	80-150	90-180	90-130	130-170	120-200
		hardened and tempered	1100	50-100	60-70	50-100	50-120	40-140	40-130	90-180	60-100	80-130	50-100
	Stainless steel and cast steel	ferritic/martensitic, annealed	700	100-170	80-140	140-180	60-160	40-180	40-150	70-180	120-170	130-180	140-180
		martensitic, hardened and tempered	1000	90-150	70-120	110-140	50-100	40-160	40-140	70-180	80-130	110-160	110-160
M	Stainless steel and cast steel	austenitic and austenitic/ferritic	450-600	110-170	80-150	120-200	60-160	80-180	80-160	60-200	70-180	100-170	110-190
		chilled	600-900	80-150	-	90-160	50-100	40-140	40-130	60-200	60-130	-	80-150
K	Cast iron	pearlitic, ferritic	500-700	-	-	120-160	-	180-350	180-300	-	-	130-200	-
		pearlitic, martensitic	700-850	-	-	90-130	-	160-300	160-280	-	-	120-180	-
			800-1100	-	-	-	-	120-270	120-240	-	-	-	-
	Cast iron with nodular graphite	ferritic	550	-	-	120-160	-	140-230	140-230	-	-	120-170	-
		pearlitic	800	-	-	120-180	-	120-170	120-170	-	-	120-190	-
	Malleable cast iron	ferritic	450	-	-	140-220	-	150-210	150-210	-	-	150-230	-
pearlitic		750	-	-	110-160	-	150-210	150-210	-	-	120-170	-	
N	Aluminum alloys, long chipping	not heat treatable	200	-	-	-	-	-	-	-	300-1000	-	-
		heat treatable, heat treated	350	-	-	-	-	-	-	-	300-700	-	-
	Casted aluminum alloys	≤ 12 % Si, hardened	250	-	-	-	-	-	-	-	300-700	-	-
		≤ 12 % Si, heat treatable, hardened	300	-	-	-	-	-	-	-	300-500	-	-
		≤ 12 % Si, not heat treatable	450	-	-	-	-	-	-	-	250-350	-	-
	Copper and copper alloys (brass/bronze)	Lead alloys, Pb > 1%	400	-	-	-	-	200-650	200-500	-	400-500	-	-
		Brass, bronze	300	-	-	-	-	200-650	200-500	-	250-350	-	-
		Aluminum bronze	500	-	-	-	-	160-350	160-300	-	300-500	-	-
		Copper and electrolyte copper	200	-	-	-	-	120-220	120-200	-	250-400	-	-
	Non-ferrous materials	Duroplastics		-	-	-	-	160-600	160-600	-	-	-	-
Reinforced plastics			-	-	-	-	100-300	100-300	-	-	-	-	
Hard rubber			-	-	-	-	-	-	-	-	-	-	
S	High temperature resistant alloys	Fe-alloyed annealed	700	-	-	20-50	-	20-70	20-60	-	35-100	20-40	20-40
		Fe-alloyed hardened	950	-	-	20-50	-	20-70	20-60	-	35-70	15-35	15-35
		Ni- oder Co- based annealed	800	-	-	15-40	-	15-60	15-50	-	-	10-30	8-25
		Ni- oder Co- based casting	1100	-	-	10-25	-	15-50	15-40	-	20-60	5-18	4-15
		Ni- oder Co- based hardened	1200	-	-	20-35	-	15-50	15-40	-	40-60	5-18	4-15
	Titanium alloys, high strength	Pure titanium	500-700	-	-	80-140	-	100-210	90-180	-	40-60	80-130	80-130
Alpha- and beta-alloys, hardened		700-1000	-	-	25-45	-	40-90	40-80	-	-	20-40	15-35	
H	Hardened steel	hardened and tempered	1000-1350	-	-	-	-	30-55	30-50	-	-	-	-
		hardened and tempered	1350-1700	-	-	-	-	15-25	10-25	-	-	-	-
	Hard cast iron	casting	1350	-	-	-	-	40-80	40-70	-	-	-	-
Hardened cast iron	hardened and tempered	1900	-	-	-	-	15-30	10-25	-	-	-	-	

The data cutting speeds given are approximate values.
It is necessary to adjust them to the individual machining operation.

More grades on the following pages. 

Milling – Carbide

coated

ISO	Material	Tensile strength [N/mm ²]	Cutting speed Vc [m/min]											
			AP2110	AP2120	AP2125	AP2310	AP2320	AP2335	AP5020	AP5030	AP5635	AR16C	AR26C	
P	Unalloyed steel and cast steel	ca. 0,15 % C	350	300–400	250–350	130–350	300–400	250–350	180–270	120–220	120–220	100–220	–	100–280
		ca. 0,45 % C	650	260–350	210–300	110–320	260–350	210–300	170–230	80–150	80–150	100–220	–	100–220
		ca. 0,75 % C	1000	240–300	180–230	90–280	240–300	180–230	160–210	60–140	60–140	100–220	–	80–150
	Low alloyed steel and cast steel		600	220–300	180–270	100–280	220–300	180–270	160–220	80–170	80–170	80–200	–	100–200
			900	180–260	160–220	90–250	180–260	160–220	140–180	60–130	60–130	80–200	–	100–170
			1200	120–220	100–200	60–210	120–220	100–200	100–160	60–120	60–120	80–200	–	80–150
	High alloyed steel, high alloyed tool steel and cast steel	annealed	700	150–220	130–200	80–190	150–220	130–200	130–180	80–140	80–140	80–200	–	70–140
		hardened and tempered	1100	70–150	70–140	60–180	70–150	70–140	70–120	50–120	50–120	80–200	–	60–90
	Stainless steel and cast steel	ferritic/martensitic, annealed	700	–	–	80–190	–	–	–	60–170	60–170	70–180	–	90–130
		martensitic, hardened and tempered	1000	–	–	70–170	–	–	–	50–100	50–100	70–180	–	70–110
M	Stainless steel and cast steel	austenitic and austenitic/ferritic	450–600	–	–	110–200	–	–	–	60–180	60–170	60–200	–	–
		chilled	600–900	–	–	120–210	–	–	–	50–100	50–100	60–200	–	–
K	Cast iron	pearlitic, ferritic	500–700	160–230	–	120–220	–	–	–	–	–	–	150–350	–
		pearlitic, martensitic	700–850	150–200	–	80–170	–	–	–	–	–	–	150–280	–
			800–1100	–	–	80–150	–	–	–	–	–	–	150–230	–
	Cast iron with nodular graphite	ferritic	550	160–210	–	80–200	–	–	–	–	–	–	150–220	80–180
		pearlitic	800	130–170	–	70–180	–	–	–	–	–	–	150–180	80–160
	Malleable cast iron	ferritic	450	150–210	–	70–180	–	–	–	–	–	–	150–270	–
pearlitic		750	150–210	–	70–160	–	–	–	–	–	–	150–200	–	
N	Aluminum alloys, long chipping	not heat treatable	200	–	–	–	–	–	–	100–500	–	–	150–1200	–
		heat treatable, heat treated	350	–	–	–	–	–	–	100–300	–	–	150–800	–
	Casted aluminum alloys	≤ 12 % Si, hardened	250	–	–	–	–	–	–	100–500	–	–	150–900	–
		≤ 12 % Si, heat treatable, hardened	300	–	–	–	–	–	–	100–300	–	–	150–600	–
		≤ 12 % Si, not heat treatable	450	–	–	–	–	–	–	100–200	–	–	–	–
	Copper and copper alloys (brass/bronze)	Lead alloys, Pb > 1 %	400	–	–	–	–	–	–	100–500	–	–	150–600	–
		Brass, bronze	300	–	–	–	–	–	–	100–500	–	–	150–400	–
		Aluminum bronze	500	–	–	–	–	–	–	100–300	–	–	–	–
		Copper and electrolyte copper	200	–	–	–	–	–	–	100–300	–	–	150–300	–
	Non-ferrous materials	Duroplastics		–	–	–	–	–	–	80–180	–	–	–	–
Reinforced plastics			–	–	–	–	–	–	60–150	–	–	–	–	
Hard rubber			–	–	–	–	–	–	100–220	–	–	–	–	
S	High temperature resistant alloys	Fe-alloyed annealed	700	–	–	60–90	–	–	–	20–50	–	–	–	
		Fe-alloyed hardened	950	–	–	60–90	–	–	–	20–40	–	–	–	
		Ni- oder Co- based annealed	800	–	–	–	–	–	–	15–25	–	–	–	
		Ni- oder Co- based casting	1100	–	–	–	–	–	–	10–20	–	–	–	
		Ni- oder Co- based hardened	1200	–	–	–	–	–	–	10–20	–	–	–	
	Titanium alloys, high strength	Pure titanium	500–700	–	–	–	–	–	–	50–120	–	–	–	
Alpha- and beta-alloys, hardened		700–1000	–	–	–	–	–	–	30–50	–	–	–		
H	Hardened steel	hardened and tempered	1000–1350	–	–	–	–	–	–	–	–	–	30–70	–
		hardened and tempered	1350–1700	–	–	–	–	–	–	–	–	–	20–60	–
	Hard cast iron	casting	1350	–	–	–	–	–	–	–	–	–	–	–
Hardened cast iron	hardened and tempered	1900	–	–	–	–	–	–	–	–	–	–	–	

The data cutting speeds given are approximate values.
It is necessary to adjust them to the individual machining operation.

Milling – Carbide

uncoated

ISO	Material	Tensile strength [N/mm ²]	Cutting speed Vc [m/min]							
			AK05F	AK10F	AK20F	AP20F	AP40F	AK1010	AK1020	
P	Unalloyed steel and cast steel	ca. 0,15 % C	350	-	-	-	90-150	90-140	-	-
		ca. 0,45 % C	650	-	-	-	90-120	90-100	-	-
		ca. 0,75 % C	1000	-	-	-	-	-	-	-
	Low alloyed steel and cast steel		600	-	-	-	-	-	-	-
			900	-	-	-	60-90	60-80	-	-
			1200	-	-	-	-	-	-	-
	High alloyed steel, high alloyed tool steel and cast steel	annealed	700	-	-	-	60-90	60-80	-	-
		hardened and tempered	1100	-	-	-	50-70	50-60	-	-
	Stainless steel and cast steel	ferritic/martensitic, annealed	700	-	-	-	80-100	80-100	-	-
martensitic, hardened and tempered		1000	-	-	-	80-100	80-100	-	-	
M	Stainless steel and cast steel	austenitic and austenitic/ferritic	450-600	-	-	-	80-100	80-100	-	-
		chilled	600-900	-	-	-	80-100	80-100	-	-
K	Cast iron	pearlitic, ferritic	500-700	90-160	90-150	90-150	-	-	120-160	120-160
		pearlitic, martensitic	700-850	80-150	80-130	80-130	-	-	90-140	90-140
			800-1100	100-140	80-130	80-130	-	-	80-140	80-140
	Cast iron with nodular graphite	ferritic	550	90-160	90-150	90-150	-	-	130-170	130-170
		pearlitic	800	100-150	80-140	80-140	-	-	90-130	90-130
	Malleable cast iron	ferritic	450	90-150	90-150	90-150	-	-	140-200	140-200
pearlitic		750	80-140	80-150	80-150	-	-	120-160	120-160	
N	Aluminum alloys, long chipping	not heat treatable	200	200-2500	200-3000	200-3000	-	-	300-2500	300-2500
		heat treatable, heat treated	350	200-1800	200-3000	200-3000	-	-	200-2000	200-2000
	Casted aluminum alloys	≤ 12 % Si, hardened	250	200-1800	200-2000	200-2000	-	-	400-1500	400-1500
		≤ 12 % Si, heat treatable, hardened	300	200-1500	200-1800	200-1800	-	-	400-1500	400-1500
		≤ 12 % Si, not heat treatable	450	200-800	200-1000	200-1000	-	-	200-800	200-800
	Copper and copper alloys (brass/bronze)	Lead alloys, Pb > 1%	400	200-600	200-600	200-600	-	-	250-600	250-600
		Brass, bronze	300	220-800	250-1000	250-1000	-	-	200-600	200-600
		Aluminum bronze	500	-	100-400	100-400	-	-	150-400	150-400
		Copper and electrolyte copper	200	250-700	200-800	200-800	-	-	150-300	150-300
	Non-ferrous materials	Duroplastics		100-700	-	-	-	-	80-180	80-180
Reinforced plastics			70-350	-	-	-	-	60-150	60-150	
Hard rubber			80-280	-	-	-	-	100-250	100-250	
S	High temperature resistant alloys	Fe-alloyed annealed	700	-	-	-	-	-	15-40	-
		Fe-alloyed hardened	950	-	-	-	-	-	8-28	-
		Ni- oder Co- based annealed	800	-	-	-	-	-	10-30	-
		Ni- oder Co- based casting	1100	-	-	-	-	-	8-25	-
		Ni- oder Co- based hardened	1200	-	-	-	-	-	8-25	-
Titanium alloys, high strength	Pure titanium	500-700	-	-	-	-	-	60-120	60-120	
Alpha- and beta-alloys, hardened		700-1000	-	-	-	-	-	30-80	30-80	
H	Hardened steel	hardened and tempered	1000-1350	-	30-40	30-40	-	-	-	-
		hardened and tempered	1350-1700	-	25-35	25-35	-	-	-	-
	Hard cast iron	casting	1350	-	-	-	-	-	-	-
Hardened cast iron	hardened and tempered	1900	-	-	-	-	-	-	-	

The data cutting speeds given are approximate values.
It is necessary to adjust them to the individual machining operation.

Milling – High Positive Inserts

coated

ISO	Material	Tensile strength [N/mm ²]	Cutting speed Vc [m/min]							
			AM15C	AM5015	AM5020	AM5025	AM5110	AM5120+	AP5210	
P	Unalloyed steel and cast steel	ca. 0,15 % C	350	220–320	220–320	200–260	180–230	220–350	180–280	220–370
		ca. 0,45 % C	650	180–250	180–290	170–240	170–190	180–310	160–250	180–330
		ca. 0,75 % C	1000	140–200	150–250	140–200	130–150	150–270	120–220	150–290
	Low alloyed steel and cast steel		600	180–250	180–280	170–240	170–190	180–300	–	180–320
			900	160–220	170–250	150–200	90–150	170–270	–	170–290
			1200	140–200	150–220	130–190	70–130	150–240	–	150–260
High alloyed steel, high alloyed tool steel and cast steel	annealed	700	140–230	80–160	70–140	120–200	80–180	–	80–180	
	hardened and tempered	1100	110–200	40–130	40–130	50–100	40–140	–	40–150	
Stainless steel and cast steel	ferritic/martensitic, annealed	700	170–260	60–180	50–160	140–180	40–180	50–160	40–140	
	martensitic, hardened and tempered	1000	110–200	40–140	40–140	110–140	40–160	40–140	40–120	
M	Stainless steel and cast steel	austenitic and austenitic/ferritic	450–600	210–250	80–160	70–150	120–200	80–180	70–150	70–150
		chilled	600–900	100–170	40–130	40–120	90–160	40–140	35–120	35–120
K	Cast iron	pearlitic, ferritic	500–700	210–250	180–300	160–280	120–160	180–350	180–300	180–350
		pearlitic, martensitic	700–850	90–130	160–280	140–260	90–130	160–300	160–280	160–300
			800–1100	90–130	120–240	120–220	–	120–270	120–240	120–270
	Cast iron with nodular graphite	ferritic	550	210–250	140–230	130–200	120–160	140–230	–	140–230
pearlitic		800	90–130	120–170	110–160	120–180	120–170	–	120–170	
Malleable cast iron	ferritic	450	210–250	150–210	140–200	140–220	150–210	–	150–210	
	pearlitic	750	90–130	150–210	140–200	110–160	150–210	–	150–210	
N	Aluminum alloys, long chipping	not heat treatable	200	–	–	–	–	–	–	–
		heat treatable, heat treated	350	–	–	–	–	–	–	–
	Casted aluminum alloys	≤ 12 % Si, hardened	250	–	–	–	–	–	–	–
		≤ 12 % Si, heat treatable, hardened	300	–	–	–	–	–	–	–
		≤ 12 % Si, not heat treatable	450	–	–	–	–	–	–	–
	Copper and copper alloys (brass/bronze)	Lead alloys, Pb > 1%	400	–	200–500	200–500	–	200–650	150–500	–
Brass, bronze		300	–	200–500	200–500	–	200–650	150–500	–	
Aluminum bronze		500	–	160–450	160–450	–	160–350	120–400	–	
Copper and electrolyte copper		200	–	100–320	100–320	–	120–220	120–250	–	
Non-ferrous materials	Duroplastics		–	160–600	160–600	–	160–600	–	–	
	Reinforced plastics		–	100–300	100–300	–	100–300	100–300	–	
	Hard rubber		–	–	–	–	–	–	–	
S	High temperature resistant alloys	Fe-alloyed annealed	700	–	20–60	20–60	20–50	20–70	20–60	20–70
		Fe-alloyed hardened	950	–	20–60	20–60	20–50	20–70	20–60	20–70
		Ni- oder Co- based annealed	800	–	15–50	15–50	15–40	15–60	15–50	15–60
		Ni- oder Co- based casting	1100	–	15–40	15–40	10–25	15–50	15–40	15–50
		Ni- oder Co- based hardened	1200	–	15–40	15–40	20–35	15–50	15–40	15–50
Titanium alloys, high strength	Pure titanium	500–700	–	90–180	90–180	80–140	100–210	–	–	
Alpha- and beta-alloys, hardened		700–1000	–	40–80	40–80	25–45	40–90	–	–	
H	Hardened steel	hardened and tempered	1000–1350	–	30–50	30–50	–	30–55	–	–
		hardened and tempered	1350–1700	–	10–25	10–25	–	15–25	–	–
	Hard cast iron	casting	1350	–	40–70	40–70	–	40–80	–	–
Hardened cast iron	hardened and tempered	1900	–	10–25	10–25	–	15–30	–	–	

The data cutting speeds given are approximate values.
It is necessary to adjust them to the individual machining operation.

More grades on the following pages. 

Milling – High Positive Inserts

coated

ISO	Material	Tensile strength [N/mm ²]	Cutting speed Vc [m/min]							
			AL10	AL20	AT10	AT20	PVD1	PVD2	AD2	
P	Unalloyed steel and cast steel	ca. 0,15 % C	350	220–320	180–280	220–320	180–280	200–290	160–250	–
		ca. 0,45 % C	650	180–290	160–250	180–290	160–250	160–260	140–220	–
		ca. 0,75 % C	1000	150–250	120–220	150–250	120–220	130–230	110–180	–
	Low alloyed steel and cast steel		600	180–280	160–250	180–280	160–250	160–250	140–220	–
			900	170–250	140–230	170–250	140–230	150–230	130–200	–
			1200	150–220	120–200	150–220	120–200	130–200	110–190	–
High alloyed steel, high alloyed tool steel and cast steel	annealed	700	–	–	–	–	–	–	–	
	hardened and tempered	1100	–	–	–	–	–	–	–	
Stainless steel and cast steel	ferritic/martensitic, annealed	700	170–290	160–280	170–290	160–280	150–260	130–220	–	
	martensitic, hardened and tempered	1000	140–280	130–280	140–280	130–280	120–250	110–200	–	
M	Stainless steel and cast steel	austenitic and austenitic/ferritic	450–600	140–280	140–240	140–280	140–240	120–250	120–200	–
		chilled	600–900	–	–	–	–	–	–	–
K	Cast iron	pearlitic, ferritic	500–700	180–300	160–270	180–300	160–270	160–270	–	–
		pearlitic, martensitic	700–850	160–280	140–250	160–280	140–250	140–250	–	–
			800–1100	120–240	110–220	120–240	110–220	110–220	–	–
	Cast iron with nodular graphite	ferritic	550	140–230	130–210	140–230	130–210	120–210	–	–
		pearlitic	800	120–170	110–150	120–170	110–150	110–150	–	–
	Malleable cast iron	ferritic	450	150–210	130–200	150–210	130–200	130–180	–	–
pearlitic		750	150–210	130–200	150–210	130–200	130–180	–	–	
N	Aluminum alloys, long chipping	not heat treatable	200	–	–	850–1300	850–1300	750–1200	750–1200	650–2000
		heat treatable, heat treated	350	–	–	400–900	400–900	350–800	350–800	300–2000
	Casted aluminum alloys	≤ 12 % Si, hardened	250	–	–	260–800	260–800	230–700	230–700	650–2000
		≤ 12 % Si, heat treatable, hardened	300	–	–	200–550	200–550	180–500	180–500	300–2000
		≤ 12 % Si, not heat treatable	450	–	–	200–500	200–500	180–450	180–450	200–2000
	Copper and copper alloys (brass/bronze)	Lead alloys, Pb > 1%	400	–	–	–	–	–	–	250–800
Brass, bronze		300	–	–	–	–	–	–	250–800	
Aluminum bronze		500	–	–	–	–	–	–	250–800	
Copper and electrolyte copper		200	–	–	–	–	–	–	130–400	
Non-ferrous materials	Duroplastics		–	–	–	–	–	–	–	
	Reinforced plastics		–	–	–	–	–	–	–	
	Hard rubber		–	–	–	–	–	–	–	
S	High temperature resistant alloys	Fe-alloyed annealed	700	20–50	20–50	20–50	20–50	15–45	15–45	–
		Fe-alloyed hardened	950	20–50	20–50	20–50	20–50	15–45	15–45	–
		Ni- oder Co- based annealed	800	15–40	15–40	15–40	15–40	10–35	10–35	–
		Ni- oder Co- based casting	1100	15–30	15–30	15–30	15–30	10–25	10–25	–
		Ni- oder Co- based hardened	1200	15–30	15–30	15–30	15–30	10–25	10–25	–
Titanium alloys, high strength	Pure titanium	500–700	–	–	–	–	–	–	–	
Alpha- and beta-alloys, hardened		700–1000	–	–	–	–	–	–	–	
H	Hardened steel	hardened and tempered	1000–1350	–	–	–	–	–	–	–
		hardened and tempered	1350–1700	–	–	–	–	–	–	–
	Hard cast iron	casting	1350	–	–	–	–	–	–	–
Hardened cast iron	hardened and tempered	1900	–	–	–	–	–	–	–	

The data cutting speeds given are approximate values.
It is necessary to adjust them to the individual machining operation.

Milling – High Positive Inserts

uncoated

ISO	Material		Tensile strength [N/mm ²]	Cutting speed Vc [m/min]			
				AK10	AK20	AK10F	AK20F
P	Unalloyed steel and cast steel	ca. 0,15 % C	350	-	-	-	-
		ca. 0,45 % C	650	-	-	-	-
		ca. 0,75 % C	1000	-	-	-	-
	Low alloyed steel and cast steel		600	-	-	-	-
			900	-	-	-	-
			1200	-	-	-	-
	High alloyed steel, high alloyed tool steel and cast steel	annealed	700	-	-	-	-
hardened and tempered		1100	-	-	-	-	
Stainless steel and cast steel	ferritic/martensitic, annealed	700	-	-	-	-	
	martensitic, hardened and tempered	1000	-	-	-	-	
M	Stainless steel and cast steel	austenitic and austenitic/ferritic	450-600	-	-	-	-
		chilled	600-900	-	-	-	-
K	Cast iron	pearlitic, ferritic	500-700	120-160	120-160	90-150	90-150
		pearlitic, martensitic	700-850	90-140	90-140	80-130	80-130
			800-1100	80-140	80-140	80-130	80-130
	Cast iron with nodular graphite	ferritic	550	130-170	130-170	90-150	90-150
		pearlitic	800	90-130	90-130	80-140	80-140
	Malleable cast iron	ferritic	450	140-200	140-200	90-150	90-150
		pearlitic	750	120-160	120-160	80-150	80-150
N	Aluminum alloys, long chipping	not heat treatable	200	300-2500	300-2500	200-3000	200-3000
		heat treatable, heat treated	350	200-2000	200-2000	200-3000	200-3000
	Casted aluminum alloys	≤ 12 % Si, hardened	250	400-1500	400-1500	200-2000	200-2000
		≤ 12 % Si, heat treatable, hardened	300	400-1500	400-1500	200-1800	200-1800
		≤ 12 % Si, not heat treatable	450	200-800	200-800	200-1000	200-1000
	Copper and copper alloys (brass/bronze)	Lead alloys, Pb > 1 %	400	250-600	250-600	200-600	200-600
		Brass, bronze	300	200-600	200-600	250-1000	250-1000
Aluminum bronze		500	150-400	150-400	100-400	100-400	
Copper and electrolyte copper		200	150-300	150-300	200-800	200-800	
Non-ferrous materials	Duroplastics		80-180	80-180	-	-	
	Reinforced plastics		60-150	60-150	-	-	
	Hard rubber		100-250	100-250	-	-	
S	High temperature resistant alloys	Fe-alloyed annealed	700	15-40	-	-	-
		Fe-alloyed hardened	950	8-28	-	-	-
		Ni- oder Co- based annealed	800	10-30	-	-	-
		Ni- oder Co- based casting	1100	8-25	-	-	-
		Ni- oder Co- based hardened	1200	8-25	-	-	-
	Titanium alloys, high strength	Pure titanium	500-700	60-120	-	-	-
Alpha- and beta-alloys, hardened		700-1000	30-80	30-80	-	-	
H	Hardened steel	hardened and tempered	1000-1350	-	-	30-40	30-40
		hardened and tempered	1350-1700	-	-	25-35	25-35
	Hard cast iron	casting	1350	-	-	-	-
Hardened cast iron	hardened and tempered	1900	-	-	-	-	

The data cutting speeds given are approximate values.
It is necessary to adjust them to the individual machining operation.

Milling – CERMET / PCD / CBN / HSS

ISO	Material	Tensile strength [N/mm ²]	Cutting speed Vc [m/min]										
			AP6510	AC90C	AP6010	ACE6	AH7510	AH7516	AH7520	AB8020	HSS-TIN	HSS-TiAlN	
P	Unalloyed steel and cast steel	ca. 0,15 % C	350	100-500	160-460	100-450	100-400	-	-	-	-	70-100	80-110
		ca. 0,45 % C	650	80-500	90-430	80-450	80-370	-	-	-	-	65-90	70-100
		ca. 0,75 % C	1000	50-350	60-400	50-350	50-350	-	-	-	-	35-55	30-60
	Low alloyed steel and cast steel		600	80-500	90-350	80-450	80-300	-	-	-	-	30-80	35-90
			900	70-500	80-300	70-450	70-270	-	-	-	-	30-80	35-90
			1200	50-350	60-300	50-350	50-250	-	-	-	-	30-60	35-70
	High alloyed steel, high alloyed tool steel and cast steel	annealed	700	60-320	90-230	60-250	80-200	-	-	-	-	30-60	35-70
		hardened and tempered	1100	50-180	60-180	50-180	50-160	-	-	-	-	-	-
	Stainless steel and cast steel	ferritic/martensitic, annealed	700	80-350	90-290	80-300	80-250	-	-	-	-	20-35	20-40
martensitic, hardened and tempered		1000	80-400	-	80-350	80-250	-	-	-	-	-	-	
M	Stainless steel and cast steel	austenitic and austenitic/ferritic	450-600	80-380	-	80-300	80-240	-	-	-	-	20-35	20-40
		chilled	600-900	60-350	-	60-300	80-240	-	-	-	-	-	-
K	Cast iron	pearlitic, ferritic	500-700	100-500	-	100-300	80-300	700-2000	-	-	-	-	-
		pearlitic, martensitic	700-850	100-380	-	100-300	80-260	500-900	-	-	-	-	-
			800-1100	100-350	-	100-300	80-240	-	-	-	-	-	-
	Cast iron with nodular graphite	ferritic	550	80-350	80-300	100-300	80-300	-	-	-	-	-	-
		pearlitic	800	80-350	80-250	100-300	80-250	-	-	-	-	-	-
	Malleable cast iron	ferritic	450	80-350	80-350	100-300	80-350	-	-	-	-	-	-
pearlitic		750	80-350	60-250	100-300	60-250	-	-	-	-	-	-	
N	Aluminum alloys, long chipping	not heat treatable	200	-	-	-	-	-	-	-	400-2500	400-900	400-900
		heat treatable, heat treated	350	-	-	-	-	-	-	-	300-2500	140-240	150-250
	Casted aluminum alloys	≤ 12 % Si, hardened	250	-	-	-	-	-	-	-	400-2000	140-240	150-250
		≤ 12 % Si, heat treatable, hardened	300	-	-	-	-	-	-	-	400-2000	140-240	150-250
		≤ 12 % Si, not heat treatable	450	-	-	-	-	-	-	-	400-1800	60-130	70-140
	Copper and copper alloys (brass/bronze)	Lead alloys, Pb > 1%	400	-	-	-	-	-	-	-	300-1800	90-110	100-120
		Brass, bronze	300	-	-	-	-	-	-	-	400-1600	-	-
		Aluminum bronze	500	-	-	-	-	-	-	-	300-1800	-	-
		Copper and electrolyte copper	200	-	-	-	-	-	-	-	300-1800	110-180	120-200
Non-ferrous materials	Duroplastics		-	-	-	-	-	-	-	-	80-140	90-150	
	Reinforced plastics		-	-	-	-	-	-	-	200-900	-	-	
	Hard rubber		-	-	-	-	-	-	-	-	-	-	
S	High temperature resistant alloys	Fe-alloyed annealed	700	-	-	-	-	300-500	-	-	-	10-20	10-25
		Fe-alloyed hardened	950	-	-	-	-	250-350	-	-	-	10-20	10-25
		Ni- oder Co- based annealed	800	-	-	-	-	280-400	-	-	-	10-20	10-25
		Ni- oder Co- based casting	1100	-	-	-	-	200-300	-	-	-	-	-
		Ni- oder Co- based hardened	1200	-	-	-	-	200-300	-	-	-	-	-
Titanium alloys, high strength	Pure titanium	500-700	-	-	-	-	-	-	-	100-400	15-30	15-35	
Alpha- and beta-alloys, hardened		700-1000	-	-	-	-	-	-	-	100-350	15-30	15-35	
H	Hardened steel	hardened and tempered	1000-1350	-	-	-	-	-	120-250	80-180	-	-	-
		hardened and tempered	1350-1700	-	-	-	-	-	-	50-150	-	-	-
	Hard cast iron	casting	1350	-	-	-	-	60-150	-	-	-	-	-
Hardened cast iron	hardened and tempered	1900	-	-	-	-	50-150	-	-	-	-	-	

The data cutting speeds given are approximate values.
It is necessary to adjust them to the individual machining operation.

Thread Milling

ISO	Material		Tensile strength [N/mm ²]	Cutting speed Vc [m/min]		
				AL100	AM15C	AK20(P)
P	Unalloyed steel and cast steel	ca. 0,15 % C	350	115 – 190	140 – 200	-
		ca. 0,45 % C	650	100 – 190	130 – 180	-
		ca. 0,75 % C	1000	70 – 160	80 – 160	-
	Low alloyed steel and cast steel		600	85 – 145	100 – 155	-
			900	75 – 140	90 – 145	-
			1200	70 – 135	80 – 135	-
	High alloyed steel, high alloyed tool steel and cast steel	annealed	700	70 – 110	70 – 115	-
		hardened and tempered	1100	50 – 100	50 – 100	-
	Stainless steel and cast steel	ferritic/martensitic, annealed	700	75 – 140	-	-
martensitic, hardened and tempered		1000	60 – 120	-	-	
M	Stainless steel and cast steel	austenitic and austenitic/ferritic	450 – 600	70 – 130	70 – 120	-
		chilled	600 – 900	40 – 110	40 – 90	-
K	Cast iron	pearlitic, ferritic	500 – 700	70 – 130	-	-
		pearlitic, martensitic	700 – 850	60 – 120	-	-
			800 – 1100	60 – 115	-	-
	Cast iron with nodular graphite	ferritic	550	125 – 160	-	-
		pearlitic	800	90 – 120	-	-
	Malleable cast iron	ferritic	450	80 – 180	70 – 150	70 – 95
pearlitic		750	-	-	-	
N	Aluminum alloys, long chipping	not heat treatable	200	100 – 365	100 – 240	100 – 250
		heat treatable, heat treated	350	80 – 220	80 – 170	80 – 160
	Casted aluminum alloys	≤ 12 % Si, hardened	250	200 – 400	-	80 – 120
		≤ 12 % Si, heat treatable, heat treated	300	200 – 280	-	70 – 100
		≤ 12 % Si, not heat treatable	450	60 – 180	-	50 – 120
	Copper and copper alloys (brass/bronze)	Lead alloys, Pb > 1%	400	80 – 200	100 – 250	110 – 190
		Brass, bronze	300	80 – 225	80 – 200	70 – 170
		Aluminum bronze	500	-	-	-
		Copper and electrolyte copper	200	120 – 240	100 – 250	110 – 190
	Non-ferrous materials	Duroplastics		-	-	-
Reinforced plastics			-	-	-	
Hard rubber			-	-	-	
S	High temperature resistant alloys	Fe-alloyed annealed	700	45 – 60	-	30 – 50
		Fe-alloyed hardened	950	30 – 50	-	25 – 40
		Ni- oder Co- based annealed	800	20 – 30	-	20 – 30
		Ni- oder Co- based casting	1100	-	-	-
		Ni- oder Co- based hardened	1200	15 – 25	-	15 – 25
	Titanium alloys, high strength	Pure titanium	500 – 700	140 – 170	-	60 – 100
Alpha- and beta-alloys, hardened		700 – 1000	50 – 70	-	40 – 60	
H	Hardened steel	hardened and tempered	1000 – 1350	-	-	-
		hardened and tempered	1350 – 1700	-	-	-
	Hard cast iron	casting	1350	-	-	-
Hardened cast iron	hardened and tempered	1900	45 – 60	45 – 60	-	

The datas cutting speeds given are approximate values. It is necessary to adjust them to the individual machining operation.

Fresatura – Metallo duro

rivestito

ISO	Materiale	Resistenza [N/mm ²]	Velocità di taglio V _c (m/min)										
			AK2110	AK2120	AL136	AL160	AL260	AL360	AM2035	AM2110	AM2130	AM26C	
P	Acciaio non legati o debolmente legati	ca. 0,15 % C	350	220-380	110-260	100-250	-	120-200	110-180	180-230	-	-	100-210
		ca. 0,45 % C	650	190-330	90-150	80-150	-	90-140	90-130	170-190	-	-	80-170
		ca. 0,75 % C	1000	160-280	80-130	80-140	-	80-130	80-130	130-150	-	-	80-140
	Acciaio debolmente legati		600	180-300	170-290	-	-	60-120	-	170-190	-	-	100-170
			900	160-260	150-250	-	-	60-110	-	90-150	-	-	100-150
			1200	120-220	110-210	-	-	60-100	-	70-130	-	-	80-120
	Acciai fortemente legati, acciai da utensili	ricotto	700	140-220	130-210	90-180	-	80-120	80-120	120-200	-	-	70-130
		temprato e rinvenuto	1100	70-130	70-130	-	-	60-120	60-120	50-100	-	-	60-80
	Acciai inossidabili e stampati	ferritico/martensitico, ricotto	700	140-220	140-210	100-190	-	110-200	100-180	140-180	-	-	90-130
martensitico, temprato		1000	70-130	70-130	80-180	-	80-150	80-140	110-140	-	-	70-110	
M	Acciai inossidabili e stampati	austenitico e austenitico/ferritico	450-600	-	-	-	-	-	80-150	100-180	120-200	90-140	60-110
		trattato o temprato	600-900	-	-	-	-	80-140	80-140	70-140	70-180	-	60-120
K	Ghisa grigia	perlitica, ferritica	500-700	250-380	250-350	-	160-340	130-310	-	-	-	-	-
		perlitica, martensitica	700-850	190-300	200-300	-	140-280	120-260	-	-	-	-	-
			800-1100	-	-	-	100-210	100-190	-	-	-	-	-
	Ghisa sferoidale	ferritica	550	220-300	210-290	-	130-250	110-240	-	-	-	-	-
		perlitica	800	150-230	150-220	-	100-200	100-190	-	-	-	-	-
	Ghisa malleabile	ferritica	450	200-300	190-290	-	140-320	120-300	-	-	-	-	-
perlitica		750	170-230	150-210	-	110-240	100-220	-	-	-	-	-	
N	Leghe di alluminio a truciolo lungo	non trattabile	200	-	-	-	-	-	-	-	-	-	-
		temprabile, trattato	350	-	-	-	-	-	-	-	-	-	-
	Fusioni di Alluminio	≤ 12 % Si, temprato	250	-	-	-	-	-	-	-	-	-	-
		≤ 12 % Si, temprabile, trattato	300	-	-	-	-	-	-	-	-	-	-
		≤ 12 % Si, non trattabile	450	-	-	-	-	-	-	-	-	-	-
	Leghe di Rame (Bronzo, Ottone)	Leghe di Piombo, Pb > 1%	400	-	-	-	-	-	-	-	-	-	-
		Ottone, Bronzo	300	-	-	-	-	-	-	-	-	-	-
		Bronzo alluminio	500	-	-	-	-	-	-	-	-	-	-
		Rame e rame elettrolitico	200	-	-	-	-	-	-	-	-	-	-
Materiali non ferrosi	Plastiche dure		-	-	-	-	-	-	-	-	-	-	
	Plastiche rinforzate		-	-	-	-	-	-	-	-	-	-	
	Gomme dure		-	-	-	-	-	-	-	-	-	-	
S	Leghe refrattarie, Superleghe	a base di Fe, ricotto	700	-	-	-	-	-	-	20-40	-	-	-
		a base di Fe, temprato	950	-	-	-	-	-	-	15-35	-	-	-
		a base di Ni, ricotto	800	-	-	-	-	-	-	8-25	-	-	-
		a base di Co, da fusione	1100	-	-	-	-	-	-	4-15	-	-	-
		a base di Co, temprato	1200	-	-	-	-	-	-	4-15	-	-	-
	Leghe di Titanio	titanio puro	500-700	-	-	-	-	-	-	80-130	-	-	-
Leghe Alfa e Beta, trattate		700-1000	-	-	-	-	-	-	15-35	-	-	-	
H	Acciaio temprato	temprato e rinvenuto	1000-1350	-	-	-	-	-	-	-	-	-	-
		temprato e rinvenuto	1350-1700	-	-	-	-	-	-	-	-	-	-
	Ghisa temprata	da fusione	1350	-	-	-	-	-	-	-	-	-	-
	Ghisa trattata	temprato e rinvenuto	1900	-	-	-	-	-	-	-	-	-	-

I dati indicati in tabella sono valori approssimati.
Può essere necessario adattarli alle singole applicazioni di lavorazione.

Altre tipi li trovate nelle pagine seguenti. 

Fresatura – Metallo duro

rivestito

ISO	Materiale	Resistenza [N/mm ²]	Velocità di taglio V _c (m/min)										
			AM350	AM36C	AM5025	AM5040	AM5110	AM5120	AM5635	AP1530	AP2025	AP2035	
P	Acciaio non legati o debolmente legati	ca. 0,15% C	350	150-220	100-250	180-230	120-200	220-350	220-320	150-260	170-250	190-240	180-230
		ca. 0,45% C	650	120-150	100-200	170-190	80-150	180-310	180-290	150-260	140-200	170-200	170-190
		ca. 0,75% C	1000	100-140	80-120	130-150	60-140	150-270	150-250	150-260	120-150	130-160	130-150
	Acciaio debolmente legati		600	90-150	80-140	170-190	80-160	180-300	180-260	80-220	110-150	170-200	170-190
			900	80-140	80-120	90-150	60-130	170-270	150-220	80-220	100-120	100-160	90-150
			1200	60-130	80-100	70-130	60-120	150-240	80-190	80-220	70-100	80-140	70-130
	Acciai fortemente legati, acciai da utensili	ricotto	700	110-200	60-120	120-200	80-140	80-180	80-150	90-180	90-130	130-170	120-200
		temprato e rinvenuto	1100	50-100	60-70	50-100	50-120	40-140	40-130	90-180	60-100	80-130	50-100
	Acciai inossidabili e stampati	ferritico/martensitico, ricotto	700	100-170	80-140	140-180	60-160	40-180	40-150	70-180	120-170	130-180	140-180
		martensitico, temprato	1000	90-150	70-120	110-140	50-100	40-160	40-140	70-180	80-130	110-160	110-160
M	Acciai inossidabili e stampati	austenitico e austenitico/ferritico	450-600	110-170	80-150	120-200	60-160	80-180	80-160	60-200	70-180	100-170	110-190
		trattato o temprato	600-900	80-150	-	90-160	50-100	40-140	40-130	60-200	60-130	-	80-150
K	Ghisa grigia	perlitica, ferritica	500-700	-	-	120-160	-	180-350	180-300	-	-	130-200	-
		perlitica, martensitica	700-850	-	-	90-130	-	160-300	160-280	-	-	120-180	-
			800-1100	-	-	-	-	120-270	120-240	-	-	-	-
	Ghisa sferoidale	ferritica	550	-	-	120-160	-	140-230	140-230	-	-	120-170	-
		perlitica	800	-	-	120-180	-	120-170	120-170	-	-	120-190	-
	Ghisa malleabile	ferritica	450	-	-	140-220	-	150-210	150-210	-	-	150-230	-
perlitica		750	-	-	110-160	-	150-210	150-210	-	-	120-170	-	
N	Leghe di alluminio a truciolo lungo	non trattabile	200	-	-	-	-	-	-	-	300-1000	-	-
		temprabile, trattato	350	-	-	-	-	-	-	-	300-700	-	-
	Fusioni di Alluminio	≤ 12% Si, temprato	250	-	-	-	-	-	-	-	300-700	-	-
		≤ 12% Si, temprabile, trattato	300	-	-	-	-	-	-	-	300-500	-	-
		≤ 12% Si, non trattabile	450	-	-	-	-	-	-	-	250-350	-	-
	Leghe di Rame (Bronzo, Ottone)	Leghe di Piombo, Pb > 1%	400	-	-	-	-	200-650	200-500	-	400-500	-	-
		Ottone, Bronzo	300	-	-	-	-	200-650	200-500	-	250-350	-	-
		Bronzo alluminio	500	-	-	-	-	160-350	160-300	-	300-500	-	-
		Rame e rame elettrolitico	200	-	-	-	-	120-220	120-200	-	250-400	-	-
	Materiali non ferrosi	Plastiche dure		-	-	-	-	160-600	160-600	-	-	-	-
Plastiche rinforzate			-	-	-	-	100-300	100-300	-	-	-	-	
Gomme dure			-	-	-	-	-	-	-	-	-	-	
S	Leghe refrattarie, Superleghe	a base di Fe, ricotto	700	-	-	20-50	-	20-70	20-60	-	35-100	20-40	20-40
		a base di Fe, temprato	950	-	-	20-50	-	20-70	20-60	-	35-70	15-35	15-35
		a base di Ni, ricotto	800	-	-	15-40	-	15-60	15-50	-	-	10-30	8-25
		a base di Co, da fusione	1100	-	-	10-25	-	15-50	15-40	-	20-60	5-18	4-15
		a base di Co, temprato	1200	-	-	20-35	-	15-50	15-40	-	40-60	5-18	4-15
	Leghe di Titanio	titanio puro	500-700	-	-	80-140	-	100-210	90-180	-	40-60	80-130	80-130
Leghe Alfa e Beta, trattate		700-1000	-	-	25-45	-	40-90	40-80	-	-	20-40	15-35	
H	Acciaio temprato	temprato e rinvenuto	1000-1350	-	-	-	-	30-55	30-50	-	-	-	-
		temprato e rinvenuto	1350-1700	-	-	-	-	15-25	10-25	-	-	-	-
	Ghisa temprata	da fusione	1350	-	-	-	-	40-80	40-70	-	-	-	-
	Ghisa trattata	temprato e rinvenuto	1900	-	-	-	-	15-30	10-25	-	-	-	-

I dati indicati in tabella sono valori approssimati. Può essere necessario adattarli alle singole applicazioni di lavorazione.

Altre tipi li trovate nelle pagine seguenti. 

Fresatura – Metallo duro

rivestito

ISO	Materiale	Resistenza [N/mm ²]	Velocità di taglio V _c (m/min)												
			AP2110	AP2120	AP2125	AP2310	AP2320	AP2335	AP5020	AP5030	AP5635	AR16C	AR26C		
P	Acciaio non legati o debolmente legati	ca. 0,15% C	350	300-400	250-350	130-350	300-400	250-350	180-270	120-220	120-220	100-220	-	100-280	
		ca. 0,45% C	650	260-350	210-300	110-320	260-350	210-300	170-230	80-150	80-150	100-220	-	100-220	
		ca. 0,75% C	1000	240-300	180-230	90-280	240-300	180-230	160-210	60-140	60-140	100-220	-	80-150	
	Acciaio debolmente legati		600	220-300	180-270	100-280	220-300	180-270	160-220	80-170	80-170	80-200	-	100-200	
			900	180-260	160-220	90-250	180-260	160-220	140-180	60-130	60-130	80-200	-	100-170	
			1200	120-220	100-200	60-210	120-220	100-200	100-160	60-120	60-120	80-200	-	80-150	
	Acciai fortemente legati, acciai da utensili	ricotto	700	150-220	130-200	80-190	150-220	130-200	130-180	80-140	80-140	80-200	-	70-140	
		temprato e rinvenuto	1100	70-150	70-140	60-180	70-150	70-140	70-120	50-120	50-120	80-200	-	60-90	
	Acciai inossidabili e stampati	ferritico/martensitico, ricotto	700	-	-	80-190	-	-	-	60-170	60-170	70-180	-	90-130	
		martensitico, temprato	1000	-	-	70-170	-	-	-	50-100	50-100	70-180	-	70-110	
M	Acciai inossidabili e stampati	austenitico e austenitico/ferritico	450-600	-	-	110-200	-	-	-	60-180	60-170	60-200	-	-	
		trattato o temprato	600-900	-	-	120-210	-	-	-	50-100	50-100	60-200	-	-	
K	Ghisa grigia	perlitica, ferritica	500-700	160-230	-	120-220	-	-	-	-	-	-	150-350	-	
		perlitica, martensitica	700-850	150-200	-	80-170	-	-	-	-	-	-	-	150-280	-
			800-1100	-	-	80-150	-	-	-	-	-	-	-	150-230	-
	Ghisa sferoidale	ferritica	550	160-210	-	80-200	-	-	-	-	-	-	-	150-220	80-180
		perlitica	800	130-170	-	70-180	-	-	-	-	-	-	-	150-180	80-160
	Ghisa malleabile	ferritica	450	150-210	-	70-180	-	-	-	-	-	-	-	150-270	-
perlitica		750	150-210	-	70-160	-	-	-	-	-	-	-	150-200	-	
N	Leghe di alluminio a truciolo lungo	non trattabile	200	-	-	-	-	-	-	-	100-500	-	-	150-1200	-
		temprabile, trattato	350	-	-	-	-	-	-	-	100-300	-	-	150-800	-
	Fusioni di Alluminio	≤ 12% Si, temprato	250	-	-	-	-	-	-	-	100-500	-	-	150-900	-
		≤ 12% Si, temprabile, trattato	300	-	-	-	-	-	-	-	100-300	-	-	150-600	-
		≤ 12% Si, non trattabile	450	-	-	-	-	-	-	-	100-200	-	-	-	-
	Leghe di Rame (Bronzo, Ottone)	Leghe di Piombo, Pb > 1%	400	-	-	-	-	-	-	-	100-500	-	-	150-600	-
		Ottone, Bronzo	300	-	-	-	-	-	-	-	100-500	-	-	150-400	-
		Bronzo alluminio	500	-	-	-	-	-	-	-	100-300	-	-	-	-
		Rame e rame elettrolitico	200	-	-	-	-	-	-	-	100-300	-	-	150-300	-
	Materiali non ferrosi	Plastiche dure		-	-	-	-	-	-	-	80-180	-	-	-	-
Plastiche rinforzate			-	-	-	-	-	-	-	60-150	-	-	-	-	
Gomme dure			-	-	-	-	-	-	-	100-220	-	-	-	-	
S	Leghe refrattarie, Superleghe	a base di Fe, ricotto	700	-	-	60-90	-	-	-	20-50	-	-	-	-	
		a base di Fe, temprato	950	-	-	60-90	-	-	-	20-40	-	-	-	-	
		a base di Ni, ricotto	800	-	-	-	-	-	-	15-25	-	-	-	-	
		a base di Co, da fusione	1100	-	-	-	-	-	-	10-20	-	-	-	-	
		a base di Co, temprato	1200	-	-	-	-	-	-	10-20	-	-	-	-	
	Leghe di Titanio	titanio puro	500-700	-	-	-	-	-	-	50-120	-	-	-	-	
Leghe Alfa e Beta, trattate		700-1000	-	-	-	-	-	-	30-50	-	-	-	-		
H	Acciaio temprato	temprato e rinvenuto	1000-1350	-	-	-	-	-	-	-	-	-	30-70	-	
		temprato e rinvenuto	1350-1700	-	-	-	-	-	-	-	-	-	-	20-60	-
	Ghisa temprata	da fusione	1350	-	-	-	-	-	-	-	-	-	-	-	
	Ghisa trattata	temprato e rinvenuto	1900	-	-	-	-	-	-	-	-	-	-	-	

I dati indicati in tabella sono valori approssimati. Può essere necessario adattarli alle singole applicazioni di lavorazione.

Altre tipi li trovate nelle pagine seguenti. 

i

Fresatura – Metallo duro

non rivestito

ISO	Materiale	Resistenza [N/mm ²]	Velocità di taglio V _c (m/min)							
			AK05F	AK10F	AK20F	AP20F	AP40F	AK1010	AK1020	
P	Acciaio non legati o debolmente legati	ca. 0,15 % C	350	-	-	-	90-150	90-140	-	-
		ca. 0,45 % C	650	-	-	-	90-120	90-100	-	-
		ca. 0,75 % C	1000	-	-	-	-	-	-	-
	Acciaio debolmente legati		600	-	-	-	-	-	-	-
			900	-	-	-	60-90	60-80	-	-
			1200	-	-	-	-	-	-	-
	Acciai fortemente legati, acciai da utensili	ricotto	700	-	-	-	60-90	60-80	-	-
		temprato e rinvenuto	1100	-	-	-	50-70	50-60	-	-
	Acciai inossidabili e stampati	ferritico/martensitico, ricotto	700	-	-	-	80-100	80-100	-	-
martensitico, temprato		1000	-	-	-	80-100	80-100	-	-	
M	Acciai inossidabili e stampati	austenitico e austenitico/ferritico	450-600	-	-	-	80-100	80-100	-	-
		trattato o temprato	600-900	-	-	-	80-100	80-100	-	-
K	Ghisa grigia	perlitica, ferritica	500-700	90-160	90-150	90-150	-	-	120-160	120-160
		perlitica, martensitica	700-850	80-150	80-130	80-130	-	-	90-140	90-140
			800-1100	100-140	80-130	80-130	-	-	80-140	80-140
	Ghisa sferoidale	ferritica	550	90-160	90-150	90-150	-	-	130-170	130-170
		perlitica	800	100-150	80-140	80-140	-	-	90-130	90-130
	Ghisa malleabile	ferritica	450	90-150	90-150	90-150	-	-	140-200	140-200
perlitica		750	80-140	80-150	80-150	-	-	120-160	120-160	
N	Leghe di alluminio a truciolo lungo	non trattabile	200	200-2500	200-3000	200-3000	-	-	300-2500	300-2500
		temprabile, trattato	350	200-1800	200-3000	200-3000	-	-	200-2000	200-2000
	Fusioni di Alluminio	≤ 12 % Si, temprato	250	200-1800	200-2000	200-2000	-	-	400-1500	400-1500
		≤ 12 % Si, temprabile, trattato	300	200-1500	200-1800	200-1800	-	-	400-1500	400-1500
		≤ 12 % Si, non trattabile	450	200-800	200-1000	200-1000	-	-	200-800	200-800
	Leghe di Rame (Bronzo, Ottone)	Leghe di Piombo, Pb > 1%	400	200-600	200-600	200-600	-	-	250-600	250-600
		Ottone, Bronzo	300	220-800	250-1000	250-1000	-	-	200-600	200-600
		Bronzo alluminio	500	-	100-400	100-400	-	-	150-400	150-400
		Rame e rame elettrolitico	200	250-700	200-800	200-800	-	-	150-300	150-300
	Materiali non ferrosi	Plastiche dure		100-700	-	-	-	-	80-180	80-180
Plastiche rinforzate			70-350	-	-	-	-	60-150	60-150	
Gomme dure			80-280	-	-	-	-	100-250	100-250	
S	Leghe refrattarie, Superleghe	a base di Fe, ricotto	700	-	-	-	-	-	15-40	-
		a base di Fe, temprato	950	-	-	-	-	-	8-28	-
		a base di Ni, ricotto	800	-	-	-	-	-	10-30	-
		a base di Co, da fusione	1100	-	-	-	-	-	8-25	-
		a base di Co, temprato	1200	-	-	-	-	-	8-25	-
	Leghe di Titanio	titanio puro	500-700	-	-	-	-	-	60-120	60-120
Leghe Alfa e Beta, trattate		700-1000	-	-	-	-	-	30-80	30-80	
H	Acciaio temprato	temprato e rinvenuto	1000-1350	-	30-40	30-40	-	-	-	-
		temprato e rinvenuto	1350-1700	-	25-35	25-35	-	-	-	-
	Ghisa temprata	da fusione	1350	-	-	-	-	-	-	-
	Ghisa trattata	temprato e rinvenuto	1900	-	-	-	-	-	-	-

I dati indicati in tabella sono valori approssimati.
Può essere necessario adattarli alle singole applicazioni di lavorazione.

Fresatura – Ultra positivi

rivestito

ISO	Materiale	Resistenza [N/mm ²]	Velocità di taglio V _c (m/min)							
			AM15C	AM5015	AM5020	AM5025	AM5110	AM5120+	AP5210	
P	Acciaio non legati o debolmente legati	ca. 0,15 % C	350	220-320	220-320	200-260	180-230	220-350	180-280	220-370
		ca. 0,45 % C	650	180-250	180-290	170-240	170-190	180-310	160-250	180-330
		ca. 0,75 % C	1000	140-200	150-250	140-200	130-150	150-270	120-220	150-290
	Acciaio debolmente legati		600	180-250	180-280	170-240	170-190	180-300	-	180-320
			900	160-220	170-250	150-200	90-150	170-270	-	170-290
			1200	140-200	150-220	130-190	70-130	150-240	-	150-260
	Acciai fortemente legati, acciai da utensili	ricotto	700	140-230	80-160	70-140	120-200	80-180	-	80-180
		temprato e rinvenuto	1100	110-200	40-130	40-130	50-100	40-140	-	40-150
	Acciai inossidabili e stampati	ferritico/martensitico, ricotto	700	170-260	60-180	50-160	140-180	40-180	50-160	40-140
martensitico, temprato		1000	110-200	40-140	40-140	110-140	40-160	40-140	40-120	
M	Acciai inossidabili e stampati	austenitico e austenitico/ferritico	450-600	210-250	80-160	70-150	120-200	80-180	70-150	70-150
		trattato o temprato	600-900	100-170	40-130	40-120	90-160	40-140	35-120	35-120
K	Ghisa grigia	perlitica, ferritica	500-700	210-250	180-300	160-280	120-160	180-350	180-300	180-350
		perlitica, martensitica	700-850	90-130	160-280	140-260	90-130	160-300	160-280	160-300
			800-1100	90-130	120-240	120-220	-	120-270	120-240	120-270
	Ghisa sferoidale	ferritica	550	210-250	140-230	130-200	120-160	140-230	-	140-230
		perlitica	800	90-130	120-170	110-160	120-180	120-170	-	120-170
	Ghisa malleabile	ferritica	450	210-250	150-210	140-200	140-220	150-210	-	150-210
perlitica		750	90-130	150-210	140-200	110-160	150-210	-	150-210	
N	Leghe di alluminio a truciolo lungo	non trattabile	200	-	-	-	-	-	-	-
		temprabile, trattato	350	-	-	-	-	-	-	-
	Fusioni di Alluminio	≤ 12 % Si, temprato	250	-	-	-	-	-	-	-
		≤ 12 % Si, temprabile, trattato	300	-	-	-	-	-	-	-
		≤ 12 % Si, non trattabile	450	-	-	-	-	-	-	-
	Leghe di Rame (Bronzo, Ottone)	Leghe di Piombo, Pb > 1%	400	-	200-500	200-500	-	200-650	150-500	-
		Ottone, Bronzo	300	-	200-500	200-500	-	200-650	150-500	-
		Bronzo alluminio	500	-	160-450	160-450	-	160-350	120-400	-
		Rame e rame elettrolitico	200	-	100-320	100-320	-	120-220	120-250	-
Materiali non ferrosi	Plastiche dure		-	160-600	160-600	-	160-600	-	-	
	Plastiche rinforzate		-	100-300	100-300	-	100-300	100-300	-	
	Gomme dure		-	-	-	-	-	-	-	
S	Leghe refrattarie, Superleghe	a base di Fe, ricotto	700	-	20-60	20-60	20-50	20-70	20-60	20-70
		a base di Fe, temprato	950	-	20-60	20-60	20-50	20-70	20-60	20-70
		a base di Ni, ricotto	800	-	15-50	15-50	15-40	15-60	15-50	15-60
		a base di Co, da fusione	1100	-	15-40	15-40	10-25	15-50	15-40	15-50
		a base di Co, temprato	1200	-	15-40	15-40	20-35	15-50	15-40	15-50
	Leghe di Titanio	titanio puro	500-700	-	90-180	90-180	80-140	100-210	-	-
Leghe Alfa e Beta, trattate		700-1000	-	40-80	40-80	25-45	40-90	-	-	
H	Acciaio temprato	temprato e rinvenuto	1000-1350	-	30-50	30-50	-	30-55	-	-
		temprato e rinvenuto	1350-1700	-	10-25	10-25	-	15-25	-	-
	Ghisa temprata	da fusione	1350	-	40-70	40-70	-	40-80	-	-
	Ghisa trattata	temprato e rinvenuto	1900	-	10-25	10-25	-	15-30	-	-

I dati indicati in tabella sono valori approssimati.
Può essere necessario adattarli alle singole applicazioni di lavorazione.

Altre tipi li trovate nelle pagine seguenti. 

Fresatura – Ultra positivi

rivestito

ISO	Materiale	Resistenza [N/mm ²]	Velocità di taglio V _c (m/min)							
			AL10	AL20	AT10	AT20	PVD1	PVD2	AD2	
P	Acciaio non legati o debolmente legati	ca. 0,15 % C	350	220-320	180-280	220-320	180-280	200-290	160-250	-
		ca. 0,45 % C	650	180-290	160-250	180-290	160-250	160-260	140-220	-
		ca. 0,75 % C	1000	150-250	120-220	150-250	120-220	130-230	110-180	-
	Acciaio debolmente legati		600	180-280	160-250	180-280	160-250	160-250	140-220	-
			900	170-250	140-230	170-250	140-230	150-230	130-200	-
			1200	150-220	120-200	150-220	120-200	130-200	110-190	-
	Acciai fortemente legati, acciai da utensili	ricotto	700	-	-	-	-	-	-	-
		temprato e rinvenuto	1100	-	-	-	-	-	-	-
	Acciai inossidabili e stampati	ferritico/martensitico, ricotto	700	170-290	160-280	170-290	160-280	150-260	130-220	-
		martensitico, temprato	1000	140-280	130-280	140-280	130-280	120-250	110-200	-
M	Acciai inossidabili e stampati	austenitico e austenitico/ferritico	450-600	140-280	140-240	140-280	140-240	120-250	120-200	-
		trattato o temprato	600-900	-	-	-	-	-	-	-
K	Ghisa grigia	perlitica, ferritica	500-700	180-300	160-270	180-300	160-270	160-270	-	-
		perlitica, martensitica	700-850	160-280	140-250	160-280	140-250	140-250	-	-
			800-1100	120-240	110-220	120-240	110-220	110-220	-	-
	Ghisa sferoidale	ferritica	550	140-230	130-210	140-230	130-210	120-210	-	-
		perlitica	800	120-170	110-150	120-170	110-150	110-150	-	-
	Ghisa malleabile	ferritica	450	150-210	130-200	150-210	130-200	130-180	-	-
perlitica		750	150-210	130-200	150-210	130-200	130-180	-	-	
N	Leghe di alluminio a truciolo lungo	non trattabile	200	-	-	850-1300	850-1300	750-1200	750-1200	650-2000
		temprabile, trattato	350	-	-	400-900	400-900	350-800	350-800	300-2000
	Fusioni di Alluminio	≤ 12 % Si, temprato	250	-	-	260-800	260-800	230-700	230-700	650-2000
		≤ 12 % Si, temprabile, trattato	300	-	-	200-550	200-550	180-500	180-500	300-2000
		≤ 12 % Si, non trattabile	450	-	-	200-500	200-500	180-450	180-450	200-2000
	Leghe di Rame (Bronzo, Ottone)	Leghe di Piombo, Pb > 1%	400	-	-	-	-	-	-	250-800
		Ottone, Bronzo	300	-	-	-	-	-	-	250-800
		Bronzo alluminio	500	-	-	-	-	-	-	250-800
		Rame e rame elettrolitico	200	-	-	-	-	-	-	130-400
	Materiali non ferrosi	Plastiche dure		-	-	-	-	-	-	-
Plastiche rinforzate			-	-	-	-	-	-	-	
Gomme dure			-	-	-	-	-	-	-	
S	Leghe refrattarie, Superleghe	a base di Fe, ricotto	700	20-50	20-50	20-50	20-50	15-45	15-45	-
		a base di Fe, temprato	950	20-50	20-50	20-50	20-50	15-45	15-45	-
		a base di Ni, ricotto	800	15-40	15-40	15-40	15-40	10-35	10-35	-
		a base di Co, da fusione	1100	15-30	15-30	15-30	15-30	10-25	10-25	-
		a base di Co, temprato	1200	15-30	15-30	15-30	15-30	10-25	10-25	-
	Leghe di Titanio	titanio puro	500-700	-	-	-	-	-	-	-
Leghe Alfa e Beta, trattate		700-1000	-	-	-	-	-	-	-	
H	Acciaio temprato	temprato e rinvenuto	1000-1350	-	-	-	-	-	-	-
		temprato e rinvenuto	1350-1700	-	-	-	-	-	-	-
	Ghisa temprata	da fusione	1350	-	-	-	-	-	-	-
	Ghisa trattata	temprato e rinvenuto	1900	-	-	-	-	-	-	-

I dati indicati in tabella sono valori approssimati.
Può essere necessario adattarli alle singole applicazioni di lavorazione.

Fresatura – Ultra positivi

rivestito

ISO	Materiale	Resistenza [N/mm ²]	Velocità di taglio V _c (m/min)				
			AK10	AK20	AK10F	AK20F	
P	Acciaio non legati o debolmente legati	ca. 0,15 % C	350	-	-	-	-
		ca. 0,45 % C	650	-	-	-	-
		ca. 0,75 % C	1000	-	-	-	-
	Acciaio debolmente legati		600	-	-	-	-
			900	-	-	-	-
			1200	-	-	-	-
	Acciai fortemente legati, acciai da utensili	ricotto	700	-	-	-	-
temprato e rinvenuto		1100	-	-	-	-	
Acciai inossidabili e stampati	ferritico/martensitico, ricotto	700	-	-	-	-	
	martensitico, temprato	1000	-	-	-	-	
M	Acciai inossidabili e stampati	austenitico e austenitico/ferritico	450-600	-	-	-	-
		trattato o temprato	600-900	-	-	-	-
K	Ghisa grigia	perlitica, ferritica	500-700	120-160	120-160	90-150	90-150
		perlitica, martensitica	700-850	90-140	90-140	80-130	80-130
			800-1100	80-140	80-140	80-130	80-130
	Ghisa sferoidale	ferritica	550	130-170	130-170	90-150	90-150
		perlitica	800	90-130	90-130	80-140	80-140
	Ghisa malleabile	ferritica	450	140-200	140-200	90-150	90-150
perlitica		750	120-160	120-160	80-150	80-150	
N	Leghe di alluminio a truciolo lungo	non trattabile	200	300-2500	300-2500	200-3000	200-3000
		temprabile, trattato	350	200-2000	200-2000	200-3000	200-3000
	Fusioni di Alluminio	≤ 12 % Si, temprato	250	400-1500	400-1500	200-2000	200-2000
		≤ 12 % Si, temprabile, trattato	300	400-1500	400-1500	200-1800	200-1800
		≤ 12 % Si, non trattabile	450	200-800	200-800	200-1000	200-1000
	Leghe di Rame (Bronzo, Ottone)	Leghe di Piombo, Pb > 1%	400	250-600	250-600	200-600	200-600
		Ottone, Bronzo	300	200-600	200-600	250-1000	250-1000
Bronzo alluminio		500	150-400	150-400	100-400	100-400	
Rame e rame elettrolitico		200	150-300	150-300	200-800	200-800	
Materiali non ferrosi	Plastiche dure		80-180	80-180	-	-	
	Plastiche rinforzate		60-150	60-150	-	-	
	Gomme dure		100-250	100-250	-	-	
S	Leghe refrattarie, Superleghe	a base di Fe, ricotto	700	15-40	-	-	-
		a base di Fe, temprato	950	8-28	-	-	-
		a base di Ni, ricotto	800	10-30	-	-	-
		a base di Co, da fusione	1100	8-25	-	-	-
		a base di Co, temprato	1200	8-25	-	-	-
	Leghe di Titanio	titanio puro	500-700	60-120	-	-	-
Leghe Alfa e Beta, trattate		700-1000	30-80	30-80	-	-	
H	Acciaio temprato	temprato e rinvenuto	1000-1350	-	-	30-40	30-40
		temprato e rinvenuto	1350-1700	-	-	25-35	25-35
	Ghisa temprata	da fusione	1350	-	-	-	-
	Ghisa trattata	temprato e rinvenuto	1900	-	-	-	-

I dati indicati in tabella sono valori approssimati.
Può essere necessario adattarli alle singole applicazioni di lavorazione.

Fresatura – CERMET / Materiali extra duri / Acciaio super rapido

ISO	Materiale	Resistenza [N/mm ²]	Velocità di taglio V _c (m/min)										
			AP6510	AC90C	AP6010	ACE6	AH7510	AH7516	AH7520	AB8020	HSS-TIN	HSS-TAIN	
P	Acciaio non legati o debolmente legati	ca. 0,15 % C	350	100-500	160-460	100-450	100-400	-	-	-	-	70-100	80-110
		ca. 0,45 % C	650	80-500	90-430	80-450	80-370	-	-	-	-	65-90	70-100
		ca. 0,75 % C	1000	50-350	60-400	50-350	50-350	-	-	-	-	35-55	30-60
	Acciaio debolmente legati		600	80-500	90-350	80-450	80-300	-	-	-	-	30-80	35-90
			900	70-500	80-300	70-450	70-270	-	-	-	-	30-80	35-90
			1200	50-350	60-300	50-350	50-250	-	-	-	-	30-60	35-70
	Acciai fortemente legati, acciai da utensili	ricotto	700	60-320	90-230	60-250	80-200	-	-	-	-	30-60	35-70
		temprato e rinvenuto	1100	50-180	60-180	50-180	50-160	-	-	-	-	-	-
	Acciai inossidabili e stampati	ferritico/martensitico, ricotto	700	80-350	90-290	80-300	80-250	-	-	-	-	20-35	20-40
martensitico, temprato		1000	80-400	-	80-350	80-250	-	-	-	-	-	-	
M	Acciai inossidabili e stampati	austenitico e austenitico/ferritico	450-600	80-380	-	80-300	80-240	-	-	-	-	20-35	20-40
		trattato o temprato	600-900	60-350	-	60-300	80-240	-	-	-	-	-	-
K	Ghisa grigia	perlitica, ferritica	500-700	100-500	-	100-300	80-300	700-2000	-	-	-	-	-
		perlitica, martensitica	700-850	100-380	-	100-300	80-260	500-900	-	-	-	-	-
			800-1100	100-350	-	100-300	80-240	-	-	-	-	-	-
	Ghisa sferoidale	ferritica	550	80-350	80-300	100-300	80-300	-	-	-	-	-	-
		perlitica	800	80-350	80-250	100-300	80-250	-	-	-	-	-	-
	Ghisa malleabile	ferritica	450	80-350	80-350	100-300	80-350	-	-	-	-	-	-
perlitica		750	80-350	60-250	100-300	60-250	-	-	-	-	-	-	
N	Leghe di alluminio a truciolo lungo	non trattabile	200	-	-	-	-	-	-	-	400-2500	400-900	400-900
		temprabile, trattato	350	-	-	-	-	-	-	-	300-2500	140-240	150-250
	Fusioni di Alluminio	≤ 12 % Si, temprato	250	-	-	-	-	-	-	-	400-2000	140-240	150-250
		≤ 12 % Si, temprabile, trattato	300	-	-	-	-	-	-	-	400-2000	140-240	150-250
		≤ 12 % Si, non trattabile	450	-	-	-	-	-	-	-	400-1800	60-130	70-140
	Leghe di Rame (Bronzo, Ottone)	Leghe di Piombo, Pb > 1%	400	-	-	-	-	-	-	-	300-1800	90-110	100-120
		Ottone, Bronzo	300	-	-	-	-	-	-	-	400-1600	-	-
Bronzo alluminio		500	-	-	-	-	-	-	-	300-1800	-	-	
Rame e rame elettrolitico		200	-	-	-	-	-	-	-	300-1800	110-180	120-200	
Materiali non ferrosi	Plastiche dure		-	-	-	-	-	-	-	-	80-140	90-150	
	Plastiche rinforzate		-	-	-	-	-	-	-	200-900	-	-	
	Gomme dure		-	-	-	-	-	-	-	-	-	-	
S	Leghe refrattarie, Superleghe	a base di Fe, ricotto	700	-	-	-	-	300-500	-	-	-	10-20	10-25
		a base di Fe, temprato	950	-	-	-	-	250-350	-	-	-	10-20	10-25
		a base di Ni, ricotto	800	-	-	-	-	280-400	-	-	-	10-20	10-25
		a base di Co, da fusione	1100	-	-	-	-	200-300	-	-	-	-	-
		a base di Co, temprato	1200	-	-	-	-	200-300	-	-	-	-	-
	Leghe di Titanio	titanio puro	500-700	-	-	-	-	-	-	-	100-400	15-30	15-35
Leghe Alfa e Beta, trattate		700-1000	-	-	-	-	-	-	-	100-350	15-30	15-35	
H	Acciaio temprato	temprato e rinvenuto	1000-1350	-	-	-	-	-	120-250	80-180	-	-	-
		temprato e rinvenuto	1350-1700	-	-	-	-	-	-	50-150	-	-	-
	Ghisa temprata	da fusione	1350	-	-	-	-	60-150	-	-	-	-	-
	Ghisa trattata	temprato e rinvenuto	1900	-	-	-	-	50-150	-	-	-	-	-

I dati indicati in tabella sono valori approssimati. Può essere necessario adattarli alle singole applicazioni di lavorazione.

Fresatura di filettatura

ISO	Materiale	Resistenza [N/mm ²]	Velocità di taglio V _c (m/min)			
			AL100	AM15C	AK20(P)	
P	Acciaio non legati o debolmente legati	ca. 0,15 % C	350	115-190	140-200	-
		ca. 0,45 % C	650	100-190	130-180	-
		ca. 0,75 % C	1000	70-160	80-160	-
	Acciaio debolmente legati		600	85-145	100-155	-
			900	75-140	90-145	-
			1200	70-135	80-135	-
	Acciai fortemente legati, acciai da utensili	ricotto	700	70-110	70-115	-
		temprato e rinvenuto	1100	50-100	50-100	-
	Acciai inossidabili e stampati	ferritico/martensitico, ricotto	700	75-140	-	-
martensitico, temprato		1000	60-120	-	-	
M	Acciai inossidabili e stampati	austenitico e austenitico/ferritico	450-600	70-130	70-120	-
		trattato o temprato	600-900	40-110	40-90	-
K	Ghisa grigia	perlitica, ferritica	500-700	70-130	-	-
		perlitica, martensitica	700-850	60-120	-	-
			800-1100	60-115	-	-
	Ghisa sferoidale	ferritica	550	125-160	-	-
		perlitica	800	90-120	-	-
	Ghisa malleabile	ferritica	450	80-180	70-150	70-95
perlitica		750	-	-	-	
N	Leghe di alluminio a truciolo lungo	non trattabile	200	100-365	100-240	100-250
		temprabile, trattato	350	80-220	80-170	80-160
	Fusioni di Alluminio	≤ 12 % Si, temprato	250	200-400	-	80-120
		≤ 12 % Si, temprabile, trattato	300	200-280	-	70-100
		≤ 12 % Si, non trattabile	450	60-180	-	50-120
	Leghe di Rame (Bronzo, Ottone)	Leghe di Piombo, Pb > 1%	400	80-200	100-250	110-190
		Ottone, Bronzo	300	80-225	80-200	70-170
		Bronzo alluminio	500	-	-	-
		Rame e rame elettrolitico	200	120-240	100-250	110-190
	Materiali non ferrosi	Plastiche dure		-	-	-
Plastiche rinforzate			-	-	-	
Gomme dure			-	-	-	
S	Leghe refrattarie, Superleghe	a base di Fe, ricotto	700	45-60	-	30-50
		a base di Fe, temprato	950	30-50	-	25-40
		a base di Ni, ricotto	800	20-30	-	20-30
		a base di Co, da fusione	1100	-	-	-
		a base di Co, temprato	1200	15-25	-	15-25
	Leghe di Titanio	titanio puro	500-700	140-170	-	60-100
Leghe Alfa e Beta, trattate		700-1000	50-70	-	40-60	
H	Acciaio temprato	temprato e rinvenuto	1000-1350	-	-	-
		temprato e rinvenuto	1350-1700	-	-	-
	Ghisa temprata	da fusione	1350	-	-	-
	Ghisa trattata	temprato e rinvenuto	1900	45-60	45-60	-

I dati indicati in tabella sono valori approssimati.
Può essere necessario adattarli alle singole applicazioni di lavorazione.

Schnell, flexibel und individuell.

Quick, flexible and individual.

Veloce, flessibile e individuale.

- **Wir bieten Ihnen Sonderlösungen für Ihre individuellen Bedürfnisse.**
 - **Bestellen Sie bis 18 Uhr unsere Produkte, erhalten Sie Ihre Lieferung bereits am nächsten Tag.**
 - **Da wir Konstruktion, Produktion und Vertrieb unter einem Dach vereinen, können wir eine hohe Qualität unserer Produkte garantieren.**
 - **Die Mitarbeiter unseres Außendienstes besuchen Sie regelmäßig und unterstützen Sie mit ihrem Produktwissen.**
 - **Unsere Anwendungstechniker beraten Sie direkt vor Ort in Ihrem Werk.**
 - **Die kompetenten ARNO-Ansprechpartner stehen Ihnen bei Fragen und Anliegen gerne zur Verfügung – weltweit.**
- *We offer special solutions for your individual requirement.*
 - *Order your products by 15.30 CET for same day dispatch.*
 - *As we design, manufacture, and service our own products, we offer you only top quality products.*
 - *Our external sales engineers will be visiting regularly.*
 - *Our trained engineers are experienced and will be able to help you with most applications.*
 - *Our competent global ARNO-partners are always available to answer any questions you may have.*
- Offriamo soluzioni speciali per le vostre esigenze.
 - Ordinate i nostri prodotti entro le 15,30 e li avrete il giorno dopo.
 - Possiamo offrirvi la massima qualità avendo produzione, progettazione e vendita in un unico posto.
 - Verete visitati regolarmente dai nostri collaboratori.
 - I nostri tecnici sapranno consigliarvi per il meglio.
 - Tutto il team ARNO è a vostra completa disposizione.



Weitere Informationen finden Sie unter:

For more information see:

Altre informazioni sotto:

www.arno.de

Alphanumerischer Index

Alphanumerical index

Indice alfanumerico

Bezeichnung Designation Articolo	Seite Page Pagina
1	
10.4I...ISO...	263
11E...ISO...	262
11E1...BSW, BSP...	266
11I...ISO...	263
11I...UN...	265
16E...ISO...	262
16E...UN...	264
16E1...BSPT...	267
16E1...BSW, BSP...	266
16E1...DIN 40430...	268
16E1...NPT...	269
16I...ISO...	263
16I...UN...	265
2	
27E...ISO...	262
27E...UN...	264
27E1...BSW, BSP...	266
27I...ISO...	263
27I...UN...	265
4	
45FS-440V...C12	144
6	
60PA...E12	124
60PS...E12	123
68PA...E13	125
7	
70PA...D12	126
72ES...P...	148
75PA...E12	122
9	
90EA...D12	118
90EA...P10	115
90EA...P16	117
90EAQ...P10	128
90EAQ...P16	129
90EAS...P10	131
90EAS...P16	133
90ES...P10	114
90ES...P16	116
90ESQ...P10	127
90ESS...P10	130
90ESS...P16	132
90S610...N...	134 – 135
90S610M...N...	136
95EA...LN10	120
95EA...LN15	121
95ES...LN10	119

Bezeichnung Designation Articolo	Seite Page Pagina
A	
ACMA40...	139
ACME40...	138
ACME90...	137
ACV1...	153
ACV2...	154
AF45...	140
AFA...-P10	145
AFA...-P16	146
AFB90...-C...	151
AFS...C11/C16	142
AFS45...-C16	141
AFS45...T16	143
AOFT... HSS	245
APFT... Hartmetall	196 – 197
APFT... HSS	245
APHT... Hartmetall	196 – 197
APHT... Hochpositiv	213
APHX... Hochpositiv	213
APKT... Hartmetall	196 – 197
ARS180-D...	152
ASF80...	149
ASF90...	150
B	
BPFT... HSS	246
C	
CCFT... HSS	246
CCGT... CERMET	228
CCGT... Hartmetall	198 – 199
CCGT... Hochhart	237
CCGT... Hochpositiv	214 – 215
CCGW... Hochhart	238 – 239
CCMT... CERMET	228
CCMT... Hartmetall	198 – 199
CCXT... Hochpositiv	214 – 215
CPET... CERMET	229
CPGT... CERMET	229
CPGT... Hochhart	239
CPGT... Hochpositiv	216 – 217
CPGW... Hochhart	240
CPMT... CERMET	229
F	
FDA-190... -10	50, 53
FDA-190... -15	51, 54
FDC-190... -10	52, 55
FDG-190... -10	52, 55
FOA-145...	92, 93
FTA-145...	34
L	
LDFT... HSS	247
LDHT... Hartmetall	200
LDHW... Hartmetall	200
LNEX... Hartmetall	201
LNMX... Hartmetall	201
M	
MPFT... HSS	247
O	
OEHX...	96
OEMX...	96

Bezeichnung Designation Articolo	Seite Page Pagina
R	
RCFT... HSS	248
RDHT... Hartmetall	200 – 201
RDHT... Hochpositiv	216
RDHW... Hartmetall	200 – 201
RDLT... Hartmetall	200 – 201
RDLW... Hartmetall	200 – 201
ROHX...	96
ROMX...	96
RPFT... HSS	248
S	
SCFT... HSS	249
SCGT... Hochpositiv	218 – 219
SCMT... CERMET	229
SCMT... Hartmetall	202 – 203
SDFT... HSS	249
SDHT... -10	60
SDHT... Hartmetall	202 – 203
SDHT... Hochpositiv	218 – 219
SDHT...-15	61
SDHW... Hartmetall	202 – 203
SDKN... CERMET	230
SDMT... Hartmetall	202 – 203
SDMT...-10	60, 62
SDMT...-15	61, 63
SDMW...-10	62
SDMW...-15	63
SEFT... HSS	250
SEFX... HSS	250
SEHT... Hartmetall	204 – 205
SEHT... Hochpositiv	220
SEHW... Hartmetall	204 – 205
SEKN... CERMET	230
SEKN... Hartmetall	204 – 205
SEKR... Hartmetall	204 – 205
SEMT... Hartmetall	204 – 205
SNGX...	37
SNHX... Hartmetall	206
SNMX...	37
SPHT... Hartmetall	207
SPKN... Hartmetall	207
SPMT... Hartmetall	207
T	
T-976W...P...	147
TCGT... CERMET	231
TCGT... Hochhart	241
TCGT... Hochpositiv	222 – 223
TCGW... Hochhart	241 – 242
TCGX... Hartmetall	206 – 207
TCMT... CERMET	231
TCMT... Hartmetall	206 – 207
TCMX... Hartmetall	206 – 207
TCXT... Hochpositiv	222 – 223
TMC...	257
TMMC...	256
TMNC...	258
TPKN... Hartmetall	208
V	
VCGT... Hochpositiv	224
VDGT... Hochpositiv	224
X	
XDHT... Hochpositiv	225

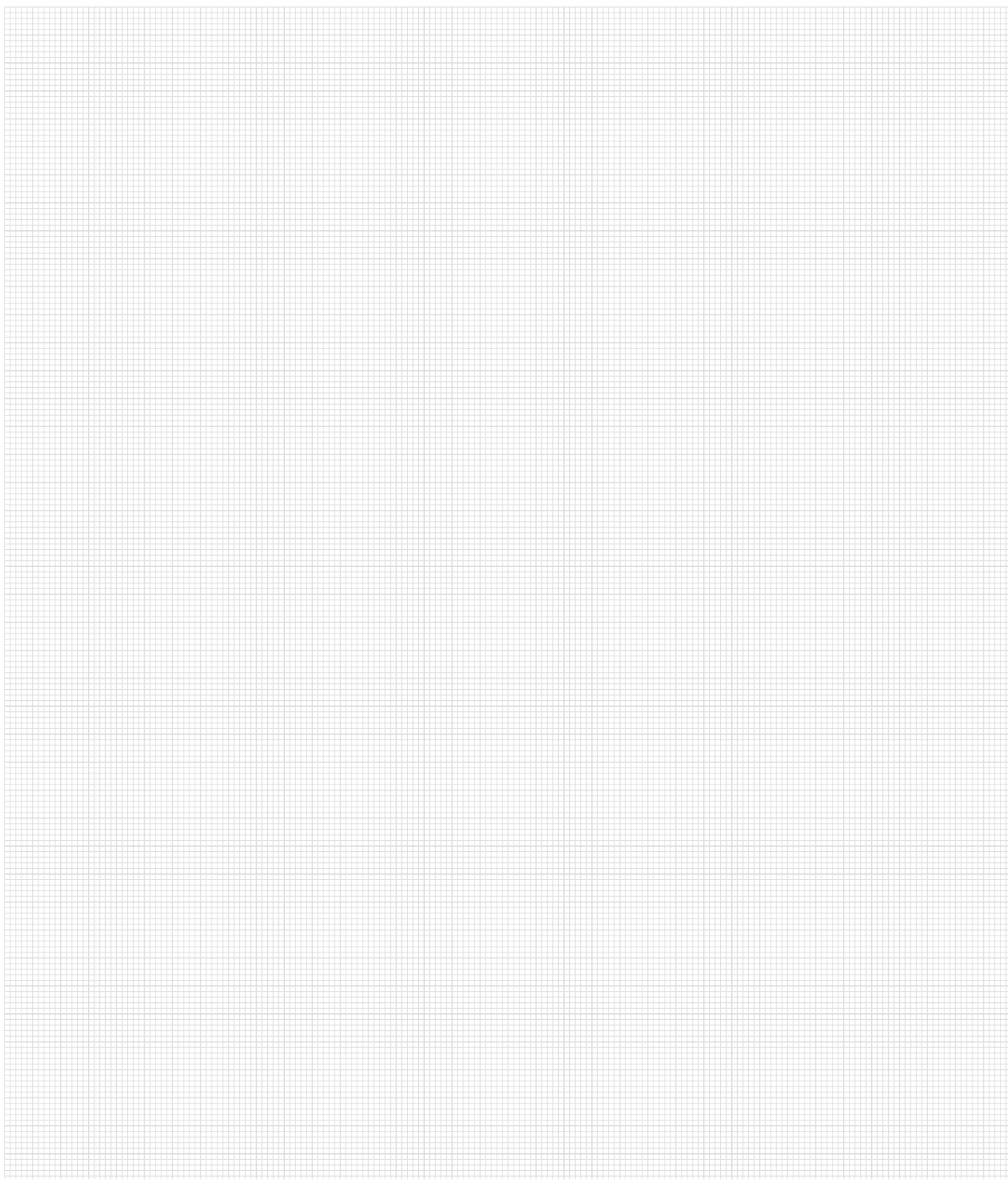

Weitere Informationen finden Sie unter
For more information see
Per maggiori informazioni visita il sito



www.arno.de

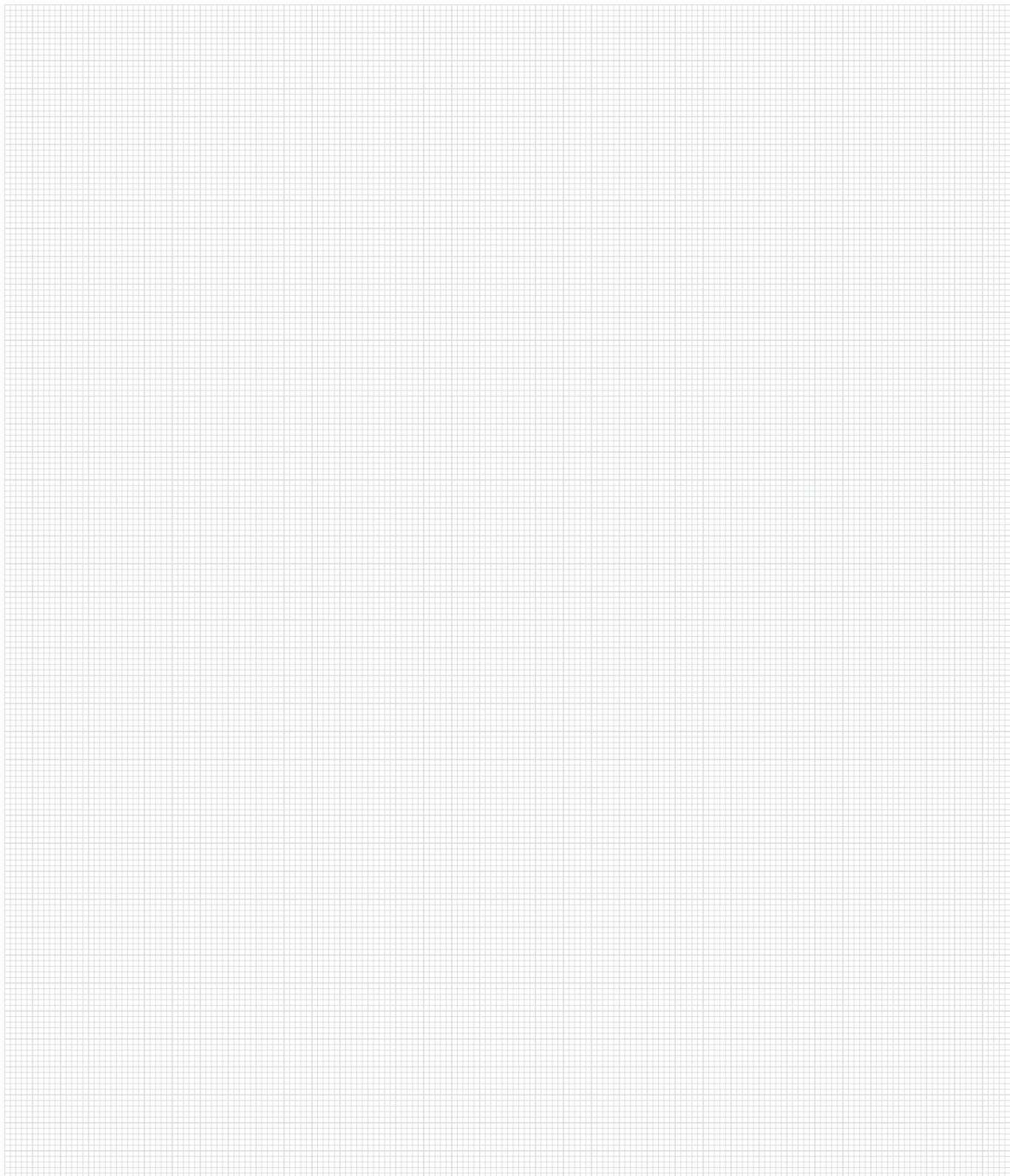

Weitere Informationen finden Sie unter
For more information see
Per maggiori informazioni visita il sito

www.arno.de

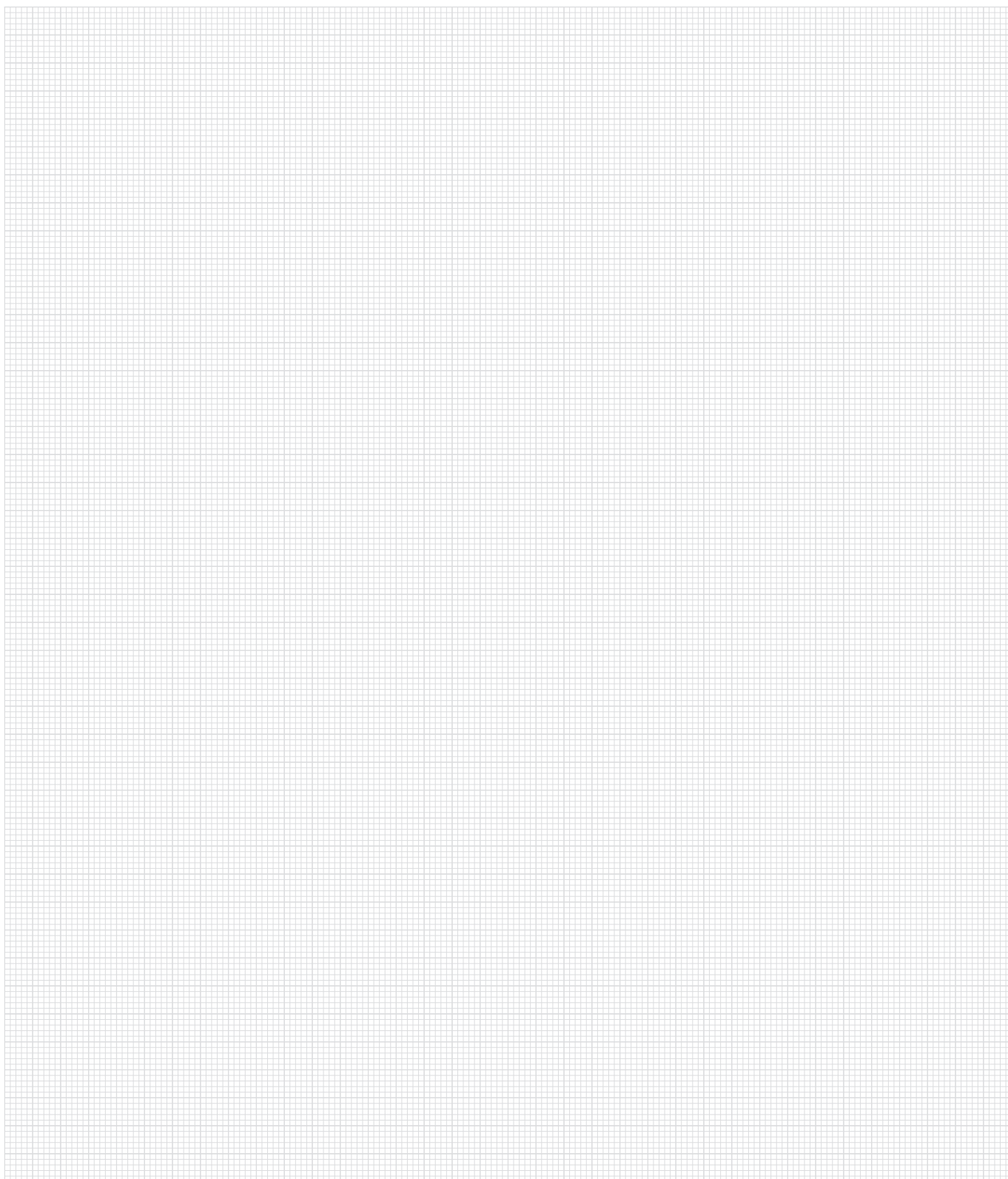

Weitere Informationen finden Sie unter
For more information see
Per maggiori informazioni visita il sito



www.arno.de

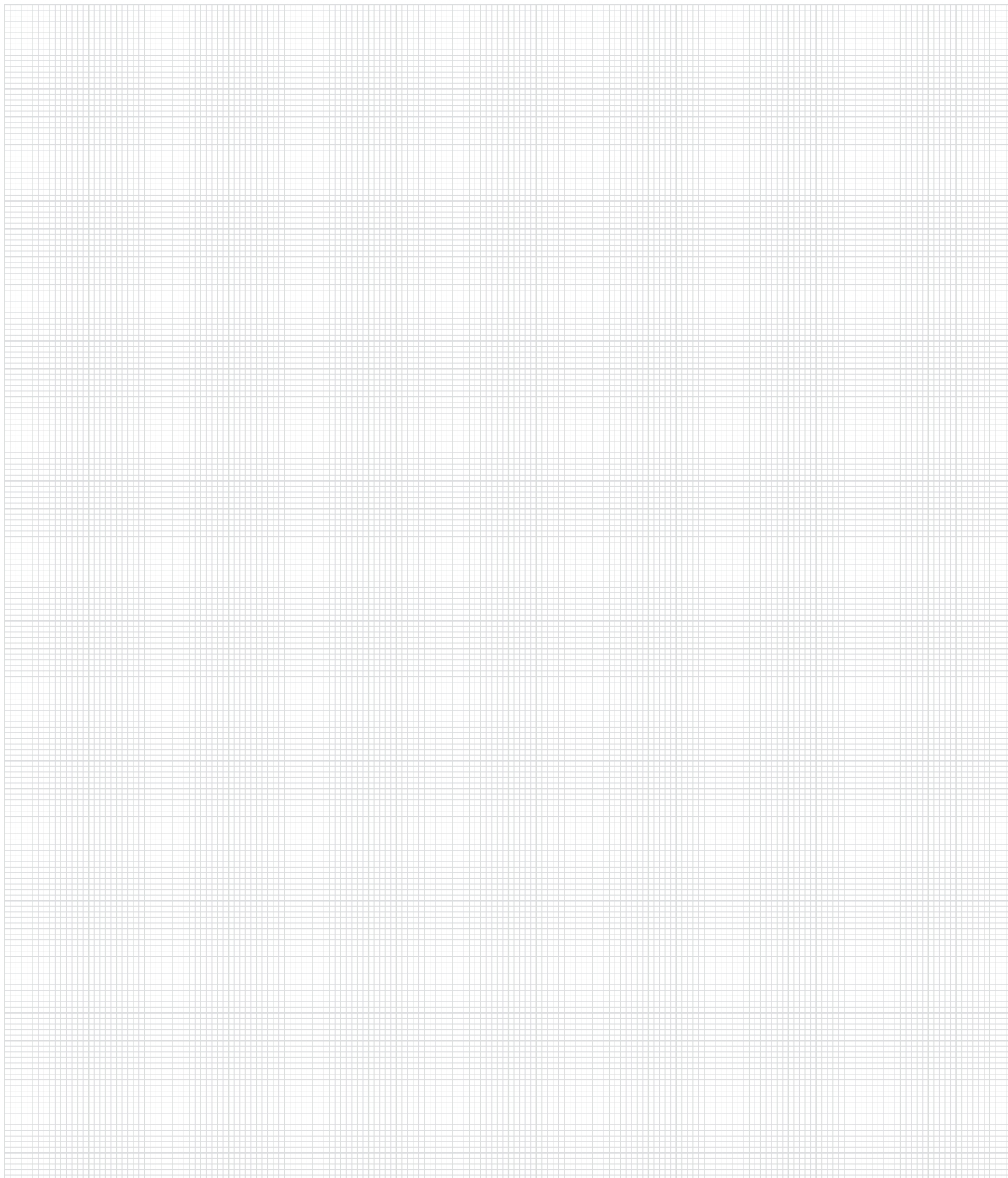

Weitere Informationen finden Sie unter
For more information see
Per maggiori informazioni visita il sito

www.arno.de

We have a passion for precision.

Mit Leidenschaft und Begeisterung den Herausforderungen unserer Kunden zu begegnen, zu tüfteln, zu entwickeln und präzise zu fertigen – das macht ARNO-Werkzeuge aus. Rund 70 Jahre Erfahrung fließen in jedes unserer Werkzeuge. Das ist zertifizierte Qualität und Präzision auf höchstem Niveau.

With passion and enthusiasm we face the challenges of our customers, to modify, develop and precisely manufacture – this is the way of ARNO-Werkzeuge. Every single tool contains the knowledge and experience of over 70 years traditional tool manufacturing. That is proven quality and precision at the highest level.

Con passione ed entusiasmo affrontiamo le sfide per sviluppare una produzione precisa – così lavora ARNO-Werkzeuge. Ogni singolo utensile contiene la conoscenza e l'esperienza di oltre 70 anni di lavorazioni. Questa è qualità e precisione al più alto livello.

The image shows a formal ISO 9001:2008 certification certificate. On the left, a vertical blue bar contains the text 'ZERTIFIKAT' and 'CERTIFICATE' in multiple languages. The main body of the certificate is white with black text. At the top right is the TÜV SÜD Management Service logo. The title 'ZERTIFIKAT' is prominently displayed in the center. Below it, the certifying body 'Die Zertifizierungsstelle der TÜV SÜD Management Service GmbH' is named, along with a statement of approval for the company 'ARNO WERKZEUGE'. The company name 'Karl-Heinz Arnold GmbH' and its address 'Karlsbader Straße 4, D-73760 Ostfildern' are listed. The scope of certification is 'Konstruktion, Lagerung und Vertrieb von Zerspanungswerkzeugen und Spannzeugen'. The certificate references an audit report number '70013372' and states that the company's quality management system meets the requirements of 'ISO 9001:2008'. The validity period is noted as '2015-11-11'. A signature and the date 'München, 2012-12-03' are present at the bottom. Logos for IAF and the specific certification scheme 'GMS-TGA-ZM-07-92' are also included.

ZERTIFIKAT ♦ CERTIFICATE ♦ 認 證 書 ♦ СЕРТИФИКАТ ♦ CERTIFICADO ♦ CERTIFICAT

TÜV SÜD Management Service

ZERTIFIKAT

Die Zertifizierungsstelle
der TÜV SÜD Management Service GmbH
bescheinigt, dass das Unternehmen

ARNO
WERKZEUGE
We have a passion for precision.

Karl-Heinz Arnold GmbH
Karlsbader Straße 4, D-73760 Ostfildern

für den Geltungsbereich

**Konstruktion, Lagerung und Vertrieb von
Zerspanungswerkzeugen und Spannzeugen**

ein Qualitätsmanagementsystem
eingeführt hat und anwendet.

Durch ein Audit, Bericht-Nr. **70013372**
wurde der Nachweis erbracht, dass die Forderungen der

ISO 9001:2008

erfüllt sind. Dieses Zertifikat ist gültig in Verbindung
mit dem Hauptzertifikat bis **2015-11-11**
Zertifikat-Registrier-Nr. **12 100 21067/01 TMS**

M. Wegner

München, 2012-12-03

IAF

GMS-TGA-ZM-07-92

TÜV SÜD Management Service GmbH • Zertifizierungsstelle • Röhlerstraße 85 • 80329 München • Germany TÜV[®]



Werkzeuge und Schneideinsätze zum Ein- und Abstechen

Tools and inserts for parting and grooving

Utensili ed inserti di troncatura e scanalatura



Werkzeuge und Wendeschneidplatten zum Drehen und Gewindedrehen

Tooling and indexable inserts for turning and threading

Utensili ed inserti di tornitura e filettatura



Werkzeuge und Wendeschneidplatten zum Fräsen und Gewindefräsen

Milling cutters and indexable inserts for milling and thread milling

Utensili ed inserti di fresatura e di filettatura di fresatura



Werkzeuge und Wendeschneidplatten zum Bohren

Drilling tools and indexable inserts for drilling

Utensili ed inserti di foratura

ARNO®
WERKZEUGE

Fordern Sie unsere weiteren Broschüren oder den Gesamtkatalog an.

For further information please ask for our complete catalogue.

Per ulteriori informazioni richiedete la raccolta cataloghi completa.
Siamo sempre al vostro servizio.



Karl-Heinz Arnold GmbH
Karlsbader Str. 4
D-73760 Ostfildern

Tel.: +49 (0)711 34 802 0
Fax: +49 (0)711 34 802 130
bestellung@arno.de
anfrage@arno.de
www.arno.de

ARNO (UK) Limited | Unit 3, Sugnall Business Centre | Sugnall, Eccleshall | Staffordshire | ST21 6NF
☎ +44 01785 850 072 | ☎ +44 01785 850 076 | sales@arno.de | www.arno-tools.co.uk

ARNO Italia S.r.l | Via J. F. Kennedy 19 | 20871 Vimercate (MB)
☎ +39 039 68 52 101 | ☎ +39 039 60 83 724 | info@arno-italia.it | www.arno-italia.it

ARNO-Werkzeuge USA LLC | 1101 W. Diggins St. | US-60033 Harvard, Illinois
☎ +1 815 943 4426 | ☎ +1 815 943 7156 | info@arnousa.com | www.arnousa.com

ARNO RU Ltd. | Krassnaja Ul. 38 | RU-600015 Vladimir
☎/☎ +7 4922 541125 | COT +7 4922 541135 | info@arnoru.ru | www.arnoru.ru